

HOW TO USE THIS CATALOG

Ordering from this online catalog is fast, easy, and secure!

Choose An Item

Figure 1 shows a sample item from the catalog. The item number and price appear in blue. To select that item, just click it once and it will be added to your order.

Of course, you can add more quantities of that item or remove it completely, before completing your order.

Note: When you click on an item, you may receive a message like the one in Figure 2. Don't be alarmed - just click "Allow" and you'll be on your way!

Chapters

Click on one of the links in Figure 3 to go to the corresponding section.

Questions?

As always, if you have questions about parts, you can call us at Automobile Atlanta at 800-792-4944

Fig. 1



Blank Keys
 Factory red or black key emblazoned with PORSCHE makes a subtle statement. The red key is a valet key, (works only the ignition and door.) The black key works everything. Easily cut by any key store.

Red Key, Blank ... [R914 531 903 11 \\$16.88](#)
 Black Key, Blank ... [R914 531 910 10 \\$16.88](#)

Fig. 2



Security Warning

The document is trying to connect to
http://www.autoatlanta.net/action.lasso?-database=AAdatabase&-layout=Item&-response=record_detailcat.lasso&-operator=eq&-partnumber=GPEX31070-maxrecords=10&-search

If you trust the site, choose Allow. If you do not trust the site, choose Block.

Remember my action for this site

Help Allow Block

Fig. 3

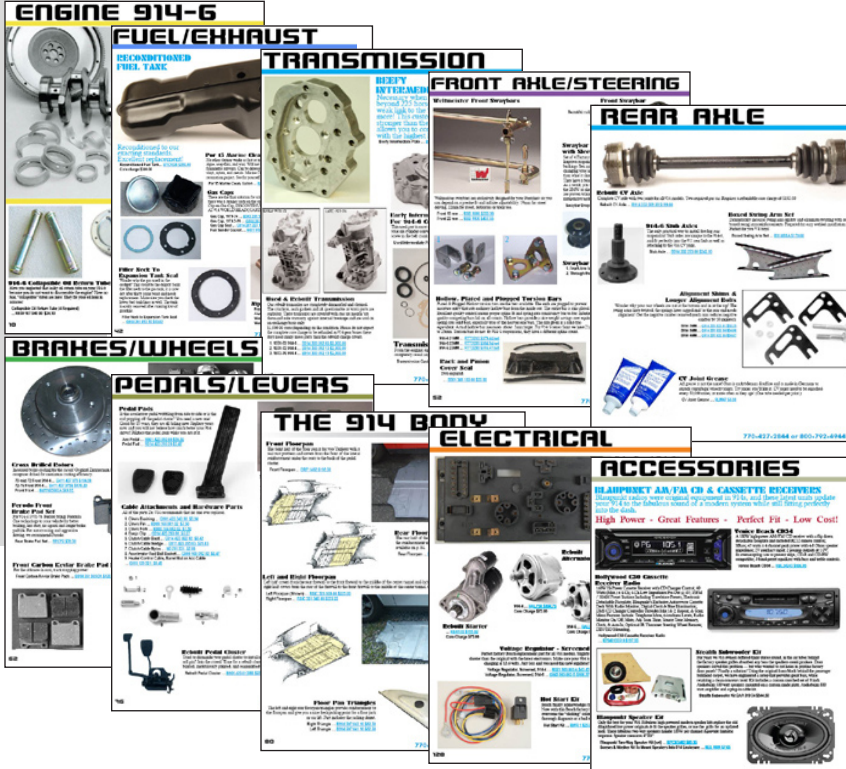

ENGINE 914-6
FUEL/EXHAUST
TRANSMISSION
FRONT AXLE/STEERING
REAR AXLE
BRAKES/WHEELS
PEDALS/LEVERS
THE 914 BODY
ELECTRICAL
ACCESSORIES

EXCELLENCE IN

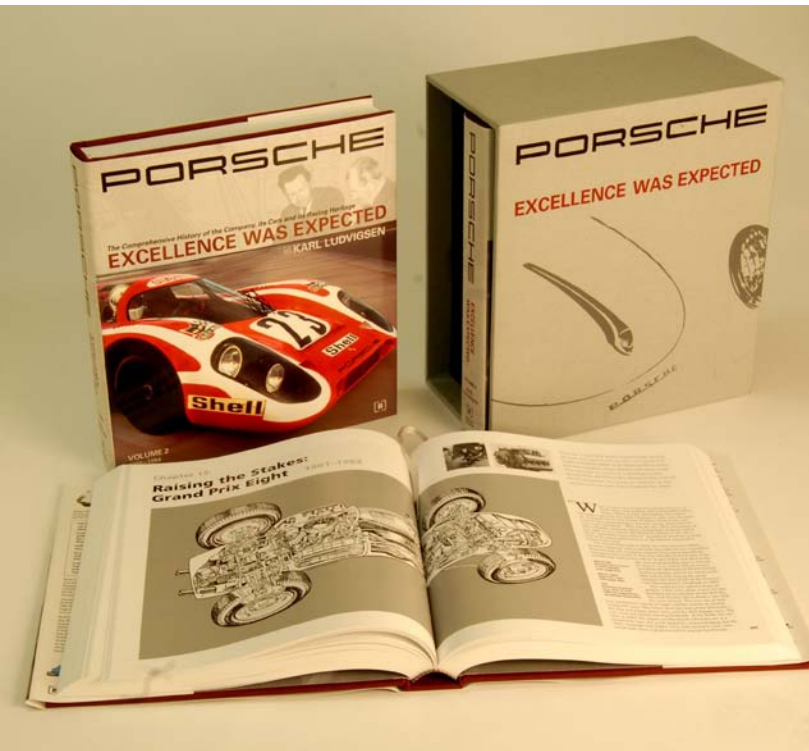

Excellence Was Expected

When the first edition of *Porsche: Excellence Was Expected* was published in 1977, reviewers sang high praises for author Karl Ludvigsen and his monumental book. Now Ludvigsen surpasses these achievements with this fully updated edition of *Porsche: Excellence Was Expected*. This new edition includes augmented versions of the 32 chapters from the 1977 book, as well as an additional 29 chapters that cover Porsche's history through 2002. This three-volume, 1,574-page set contains the photos and artwork from the original version, enhanced by over 742 new black and white photos and 50 new color drawings of Porsche production and racing cars which were commissioned specifically for this updated edition.

Porsche: Excellence Was Expected by Karl Ludvigsen
... [GPEX31070 \\$199.50](#)

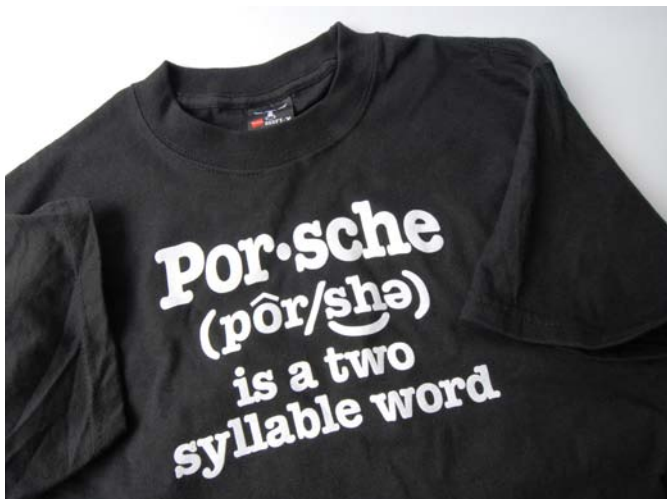

Two Syllable Tee Shirt and Sweatshirt

Proper pronunciation is essential! Wear this shirt and correct everyone's! We know Porsche is two syllables, so now they will too! 100% Cotton, High Quality. Please specify size (S, M, L, XL) and color - black or white - when ordering.

Two Syllable Tee Shirt ... [RAC1025 \\$21.95](#)

Two Syllable Sweatshirt ... [RAC2068 \\$39.95](#)

ACCESSORIES



Radar and Laser Detector/Scrambler

Radar/laser detector with fully integrated radar/laser scrambler; protects against all bands of radar and laser, including instant-on radar, while decreasing false alarms; voice alerts so you can keep your eyes on the road; 360° of coverage; includes power cord and windshield adapter; three-year warranty and 1-year ticket rebate program. This device really works as promised!

Radar and Laser Detector/Scrambler ... [BGARDETECT \\$235.00](#)



Badges

Replace your old or faded badge with a beautiful new one. Larger Type A includes base gasket and fastener, easy to install. Smaller Type B is for wheel center caps or steering wheel center. Show your Porsche identity!

Hood Badge Type A ... [R901 559 210 20 \\$33.75](#)

Hood Badge Type B ... [G644 559 210 00 \\$49.81](#)



Blank Keys

Factory red or black key emblazoned with PORSCHE makes a subtle statement. The red key is a valet key, (works only the ignition and door.) The black key works everything. Easily cut by any key store.

Red Key, Blank ... [R914 531 903 11 \\$16.88](#)

Black Key, Blank ... [R914 531 903 10 \\$16.88](#)



HEADQUARTERS



George Hussey, President and founder of Automobile Atlanta, Inc., is the man many consider to be the 914's chief promoter and enthusiast. He is the proud owner of the world's best 914 collection and has written books and articles about the car's heritage and upkeep. From his location in Marietta, Georgia, he spreads his 914 knowledge and vast parts inventory throughout the world, satisfying the needs of his fellow enthusiasts. George is always available for the most detailed technical advice or just 914 chat! Feel free to call him any time.

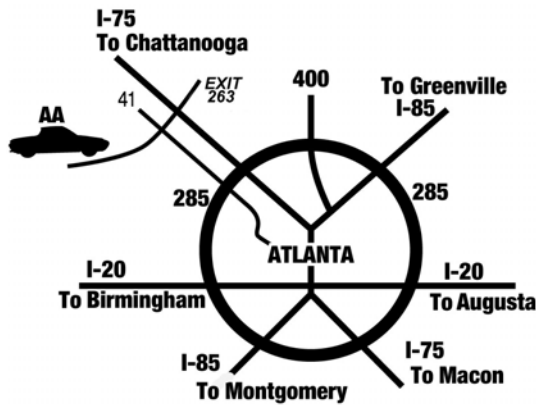

CONTENTS

Engine	p. 10
Fuel System	p. 42
Transmission	p. 48
Front Axle & Steering	p. 52
Rear Axle	p. 58
Brakes & Wheels	p. 62
Pedals & Levers	p. 76
Body Parts	p. 80
Electrical	p. 128
Accessories	p. 150
HARD PARTS	
Engine	p. 167
Fuel System	p. 179
Transmission	p. 185
Front Axle & Steering	p. 186
Rear Axle	p. 188
Brakes & Wheels	p. 190
Pedals & Levers	p. 193
Body Parts	p. 196
Electrical	p. 210



All prices are subject to change without notice.

©Copyright, Automobile Atlanta, Inc. 2007. No use may be made of the text, graphs, tables, photographs or illustrations contained in this catalog without prior written permission from Automobile Atlanta, Inc. Trademarks used in the catalog are property of their respective owners and have been used with permission.

The name Porsche® as used in our catalog is for clarification purposes only. No affiliation with or approval by Porsche® AG is intended or implied.



This near-perfect Willow Green 1971 Porsche 914-6, one of only 441 1971 models ever produced, has been written up in publications around the world, has won the prestigious Benson and Hedges concours in England four times and is touted as "the best 914-6 in the world." Totally original, the car only has 5,601 miles, which were accumulated by the first owner on his trip around the United States. This rare car was retired for a life of car shows and is on permanent display here at AUTO ATLANTA, affectionately known as "914 World Headquarters." As of this writing, the car was last shown in November 2006 at the Hilton Head Concours, where it won Best of Class. It is destined for many future Porsche-related shows. A garage queen for life!

914:



A SELECTION OF 914S FROM GEORGE HUSSEY'S STABLE

PORSCHE'S AFFORDABLE CLASSIC

Porsche's first mid-engined roadster is fun: jaunty looks, removable roof, built-in roll bar, great gas mileage, front and rear storage space. Light weight and fabulous handling make it great around town, on a trip or at the track.

The 914 is a simple, well-designed car that deserves repair, restoration and maintenance. They are easy to upgrade to current handling and performance standards. The latest 911 stuff bolts on, including the engines, transmissions, and suspensions.

Both new, used and restoration parts are available at AUTO ATLANTA. Also a multitude of accessories, some one-of-a-kind only manufactured by us.

The 914 is enjoying a well-deserved renaissance. It is a good investment with the potential to be great in today's hot roadster market.



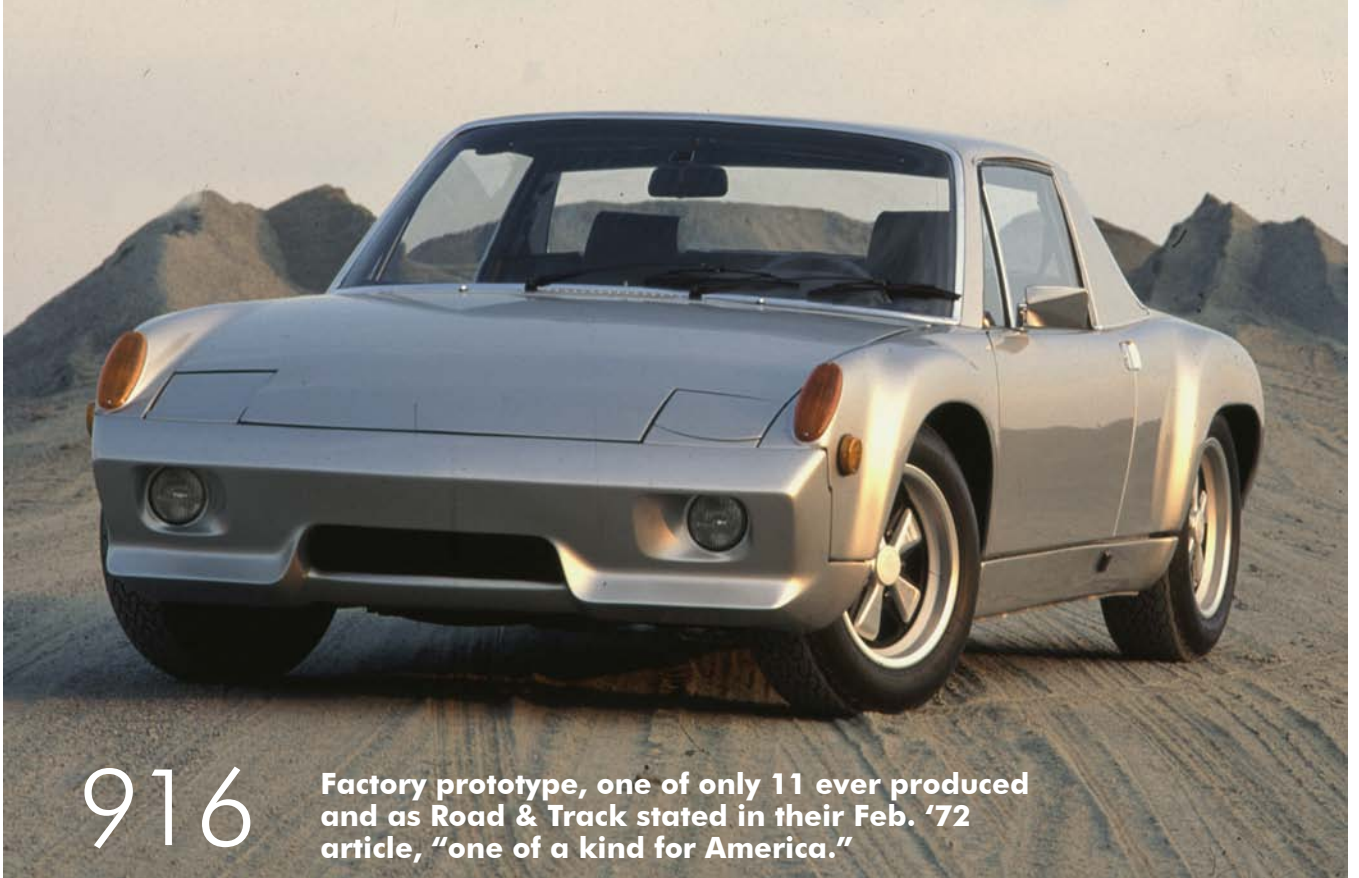

916

Factory prototype, one of only 11 ever produced and as Road & Track stated in their Feb. '72 article, "one of a kind for America."

1972 "RETRO CONCEPT" SIX

George Hussey decided to put a 914 together as he thought Porsche might have done it had the company continued to produce these cars. For the engine AUTOATLANTA used a Quick-Six mounting system together with a 3.0 liter Porsche 6 in the engine bay, fitting it with Weber carburetors, headers, and a Bursch exhaust. For additional cooling, the 914-6 GT oil cooler and GT shroud were mounted in the front trunk, with a 911 Carrera oil thermostat plumbed into the system to keep temperatures within the right range. The transaxle is a 915 unit with a 916 shift kit in-stalled to run "backwards" from its normal orientation in the 911 series. The 915 gearbox also required modification to the clutch release mechanism.



914/6 GT

Built for competition, the two-liter 914-6 GT won the first IMSA race ever held and took class wins at Le Mans and other international events.

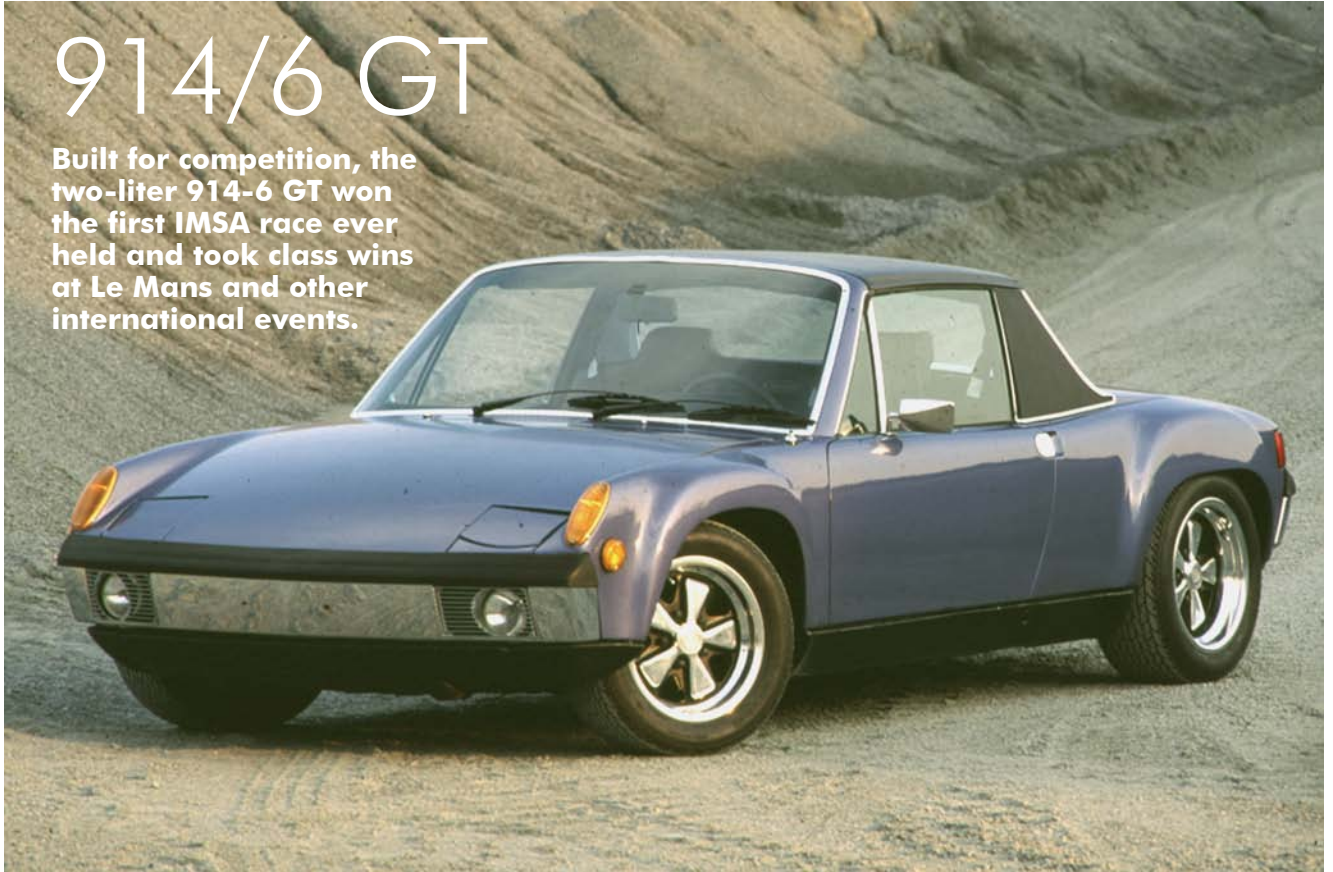

ENGINE 914-6

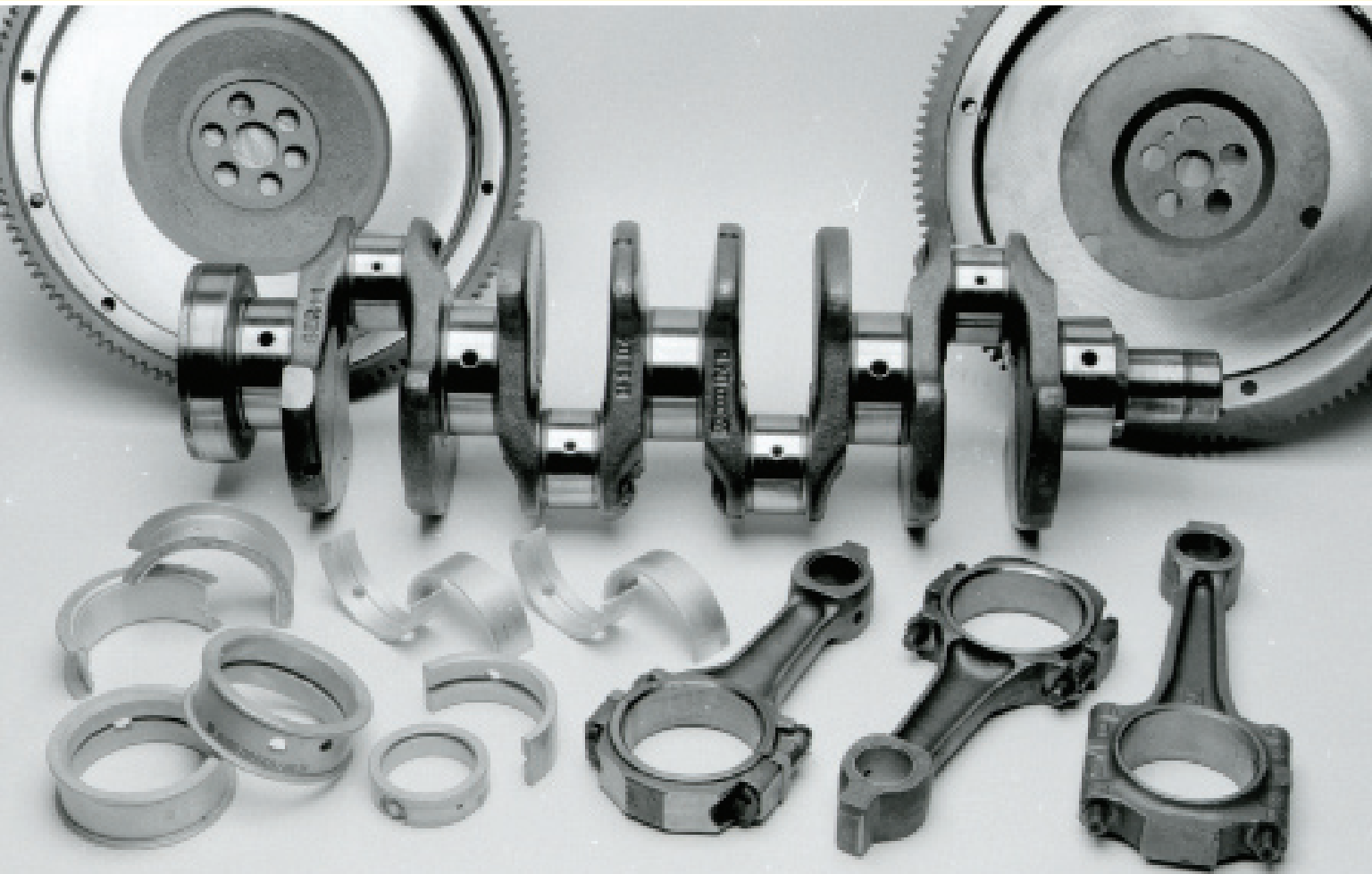

914-6 Collapsible Oil Return Tube

Have you neglected that leaky oil return tube on your 914-6 because you do not want to disassemble the engine? Have no fear, "collapsible" tubes are here! They fix your oil leak in minutes!

Collapsible Oil Return Tube (4 Required)
... R930 107 040 00 \$34.10



Oil Strainer Sump Plate Cover

... R930 101 902 00 \$43.15



Oil Return Tube Seal O-Rings

8 required.

... G999 701 112 40 \$2.42



914-6 Oil Pressure Switch Boot

Oil Pressure Switch Boot ... [R911 606 230 00 \\$10.40](#)

Oil Pressure Switch

Small sending unit for the green oil pressure light. Does not work the gauge. Easily installed - order an oil pressure switch boot as well.

Oil Pressure Switch ... [R911 606 230 00 \\$10.40](#)

Oil Temperature Switch

For the factory 914-6 gauge!

... [G911 606 112 00 \\$36.20](#)



Dual Sending Unit - Works Gauge & Light!

The oil pressure sending unit is a must for 914-6 high performance applications where oil pressure monitoring is critical. Works both the gauge and the warning light.

Sending Unit ... [RVDO 360 023 \\$43.95](#)

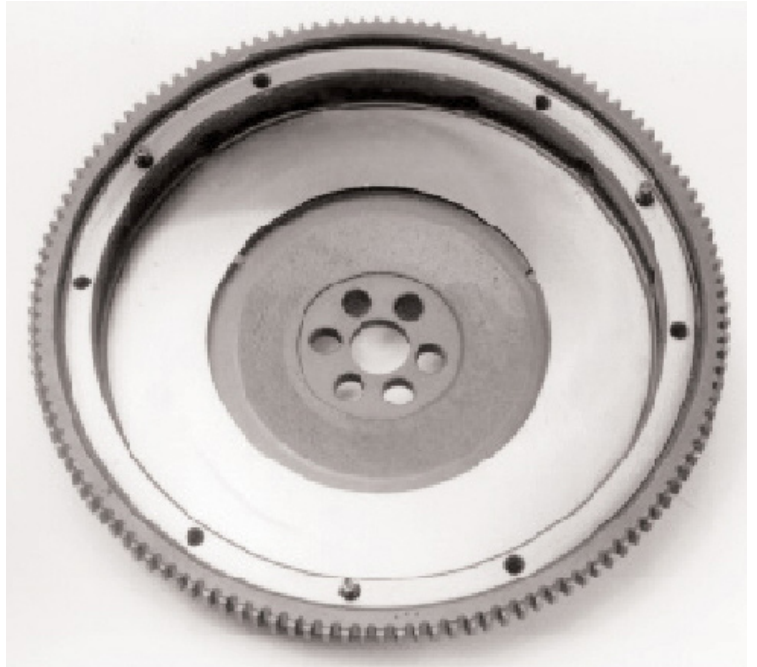

914-6 Flywheel

By now, most six cylinder flywheels have been cut too deeply or the ring gear teeth are chipped. This is the perfect time to replace this worn out part with a fresh one. Renew clutch release tolerances and make starter engagement smooth at a hell of a price! Core charge of \$75.00

914-6 Flywheel ... [R901 102 061 01 \\$395.00](#)



WORST CASE SCENARIO!

Loctite

Recommended by the factory for the tightest, leak-free sealing! We use it on all of our cases.

Loctite ... RGR 3428 \$16.45

ENGINE 914-6



Piston & Cylinder Kit For 914-6

Refresh the missing horsepower with a brand new set of pistons and cylinders. Restore the lost compression that reringing will never accomplish. Other kits available for large displacement.

914-6 Piston & Cylinder Kit (set of six)... R901 103 903 01S \$2,850.00

Piston & Cylinder Kit For 914-6, Big Bore

Bolt-on performance for your 914-6! Proven on Auto Atlanta's own vehicles. Increases displacement.

Big Bore 914-6 Piston & Cylinder Kit (set of six)
... [B901 103 903 01S \\$2,850.00](#)

930 Valve Covers For 914-6

Replace messy, dangerous leaky valve covers before the leaking oil causes a fire. Also upgrades your exhaust covers to the "turbo" style so you can forget about them warping again.

Intake Valve Cover ... R901 105 115 03 \$189.39
Exhaust Valve Cover ... R930 105 116 00 \$90.42



Valve Cover Gasket Set For 914-6

All of the gaskets and washers necessary for this critical service in one handy, leak proof kit.

Valve Cover Gasket Set, 914-6
... [R930 105 19698 \\$23.10](#)

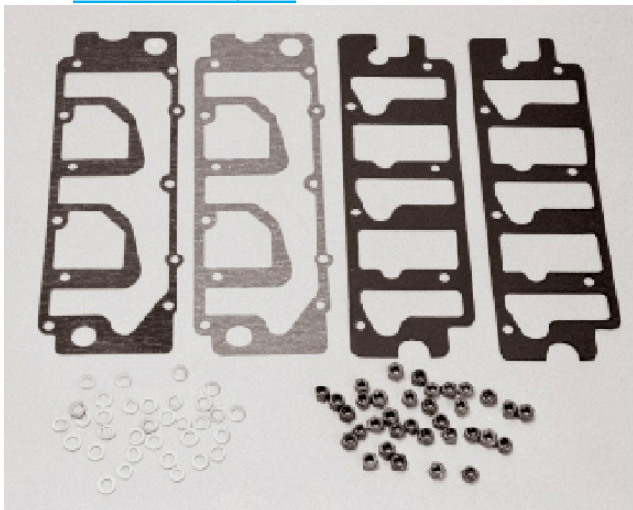

914-6 Tensioner Update Kit

Solve the collapsed tensioner syndrome with the updated oil-fed tensioner kit. The kit provides everything you need to save your 914-6 from costly tensioner failure as we have seen these oil fed tensioners last well over 200,000 miles! Easily installed without engine removal, this latest update is a must for good engine health.

914-6 Tensioner Update ... [R930 105 911/912 00 \\$625.00](#)



Rebuilt 914-6 Alternator

Although you should always test these parts first before suspecting failure, fresh new rebuilds lend confidence over the years-old originals. Guaranteed for two years, unlimited mileage.

914-6 Alternator (core \$100) ... [RAL 21X \\$340.72](#)



Outer Pulley Half

Replace your worn or warped alternator pulleys before they destroy the alternator shaft bushings. Worn nuts and pulleys may also cause belt loss leaving you stranded.

Pulley, 914-6 ... [R901 603 421 01 \\$18.70](#)

Alternator Belt, 914-6 ... [G999 192 176 50 \\$8.48](#)

Alternator Washer, 914-6 ... [G901 603 427 01 \\$4.49](#)

Pulley Shim (Each), 914-6 ... [G901 105 561 00 \\$1.74](#)

914-6 Replacement Fan

Upgrade from your inadequate 5 blade fan and enjoy superior cooling and longer engine life. A badly chipped or broken fan blade will spin your fan out of balance and will ruin the bearings in your alternator, costing you a lot more than simply replacing your damaged fan.

Replacement Fan ... [G930 106 012 00 \\$375.95](#)



GT Oil Cooler Shroud

Identical to the factory GT part, this neat item fits perfectly over the GT cooler as well as snugly against the 1970-72 front panel (1973-76 cars need slight trimming of the shroud). Ultimate cooling will result when this shroud is properly installed.

GT Oil Cooler Shroud 914 ... [B501 935 71 \\$192.50](#)

Call us for installation information. We know all of the tricks!



914-6 Sheet Metal Kit

Our five piece set of 914-6 sheet metal exactly duplicates the real thing as well as providing the unavailable right rear section. When installed, it enables your six cylinder engine to perfectly fit the engine bay. Painted to suit.

914-6 Sheet Metal Kit ... [BS916 916 106 900 90 \\$632.50](#)

ENGINE 914-6



914-6 Oil Tank Kit

An easy and economical way to install an oil tank in your 914-6 conversion comes complete with all necessary hoses and oil filter. Great value!

Repro Oil Tank Kit ... [901 107 000 00 \\$1,375.00](#)

Cam Oil Lines

... [R901 107 347 01 \\$18.15](#)

... [R901 107 348 00 \\$18.15](#)

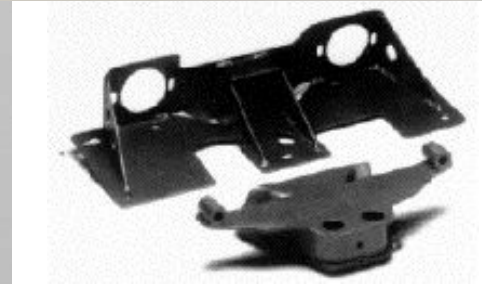

914-6 Bulkhead Mount

The quick six mounting kit enables you to immediately bolt a six-cylinder engine into your 914-4, using the factory engine pods. The '73-76 bodies, however, do require the purchase of the early rubber engine mounts. The bulkhead mount is for the serious six conversion. Welded in by a competent mechanic, it allows you to eliminate the four cylinder mounting pods allowing more clearance for valve adjust, easy removal of the rear shift bar and most importantly shifts the center of weight further forward to the factory recommended position.

Six Bulkhead Mount

... [BMIS200 \\$550.00](#)

914-6 Headers

Tuned to your engine displacement. A "must-have" for 914-6 conversions or your 914-6 race car, this precision crafted exhaust system from Dr. 914's friend Marty Schneider is available in a variety of sizes for different engine applications. Please state engine size if you have changed from the original 2.0. These systems have been proven to provide the highest horsepower for your six conversion. Believe us - we have tried them all.

914-6 Bursch Header Set

... [RBA 7918 \\$745.00](#)

914-6 MSDS Header Set

... [RMSDS 9146 \\$604.94](#)

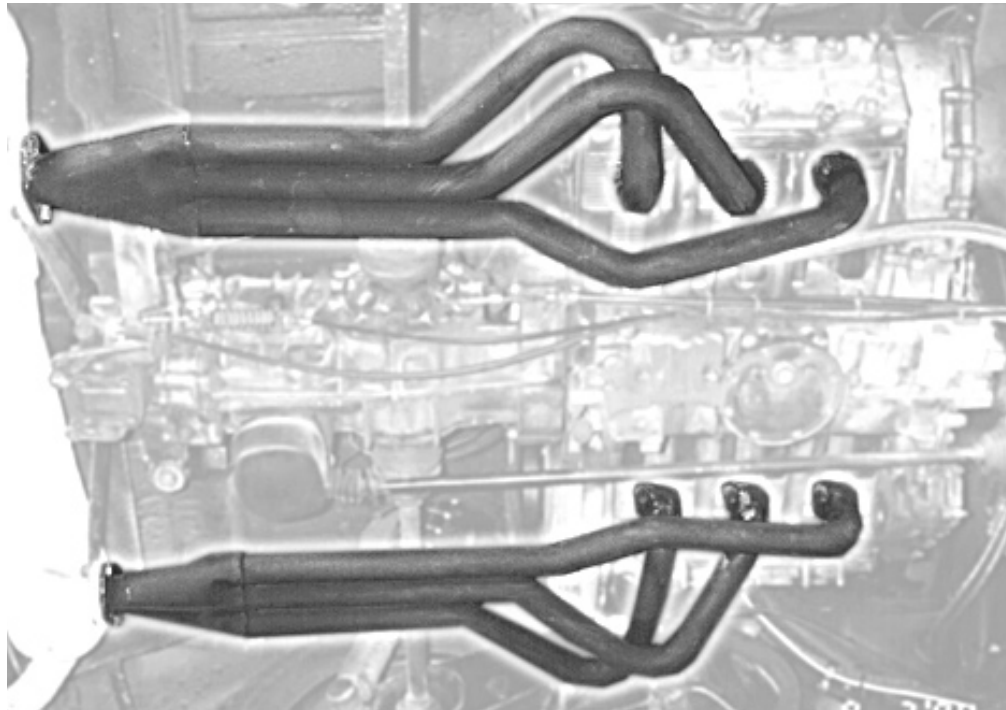

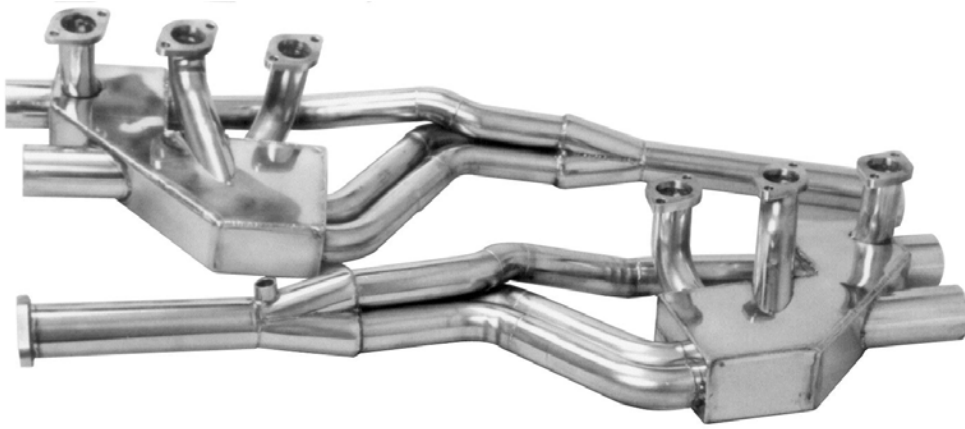

914-6 Stainless Steel Heat Exchanger Set

Finally! A great way to provide the hottest heat for your 914-6 at a fraction of the factory units! Stainless steel for a lifetime of performance.

914-6 Stainless Heat Exchanger Set
 ... [RBB 342 88 \\$2,150.00](#)

914-6 Bursch Muffler

Quiet, high performance and single tailpipe exiting through the stock valance. A good alternative to the expensive factory unit and will provide more engine power at higher RPMs for you racers.

914-6 Bursch Muffler ... [RBX 1406 \\$307.95](#)
 914-6 Muffler Gaskets (2 required) ... [R901 111 193 00 \\$8.75](#)

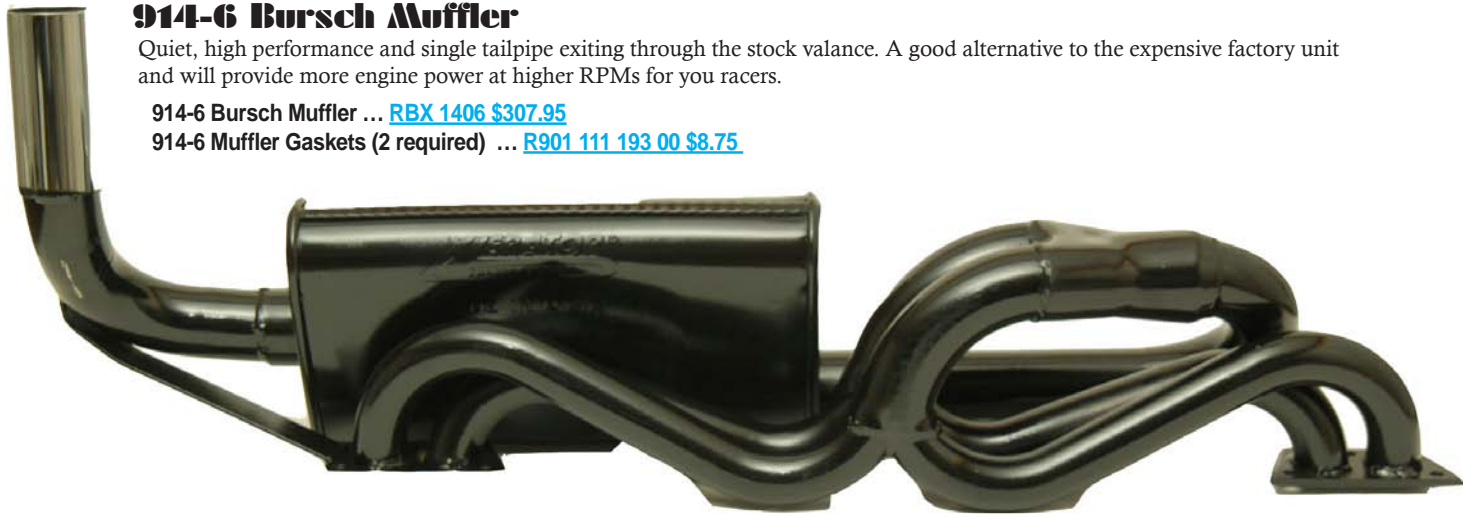

Dansk Muffler, 914-6

Dansk makes these for the factory! Keep your 914-6 stock - buy Dansk.

Dansk Muffler, 914-6
 ... [R901 111 011 11 \\$571.73](#)

Heat Exchanger/Muffler Hardware Kit

We have combined all of the necessary installation hardware in one handy kit. No longer scramble for lost, special hardware ... we'll send it to you today.

914-6 Hardware Kit ... [B900 075 148 02 \\$22.00](#)



Chrome 914-6 Tailpipe

No beautiful six is complete without this factory look tailpipe cover. Dress the ragged tail pipe tip with a shiny rolled edged chrome cover.

Chrome 914-6 Tailpipe ... [R901 111 245 01 \\$40.43](#)

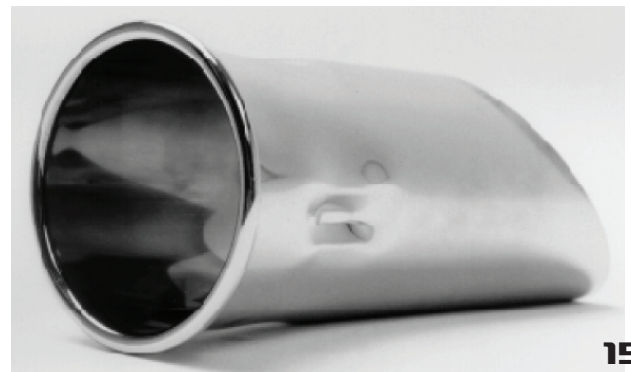

ENGINE 914-6

GT FRONT OIL COOLER

We have assembled the ultimate oil cooler kit for your larger than 2.4 liter conversion. Kit contains

every hose, clamp, thermostat, cooler, and shroud you need for a perfect conversion, along with detailed instructions. Easy to accomplish, this installation should take about 5 hours.

GT Oil Cooler Kit ... [B901 107 040 GB \\$1,595.00](#)



914-6 Clutch Package

Genuine Sachs (the best, original equipment), we add a clutch alignment tool for hassle-free installation. When you buy the kit, be sure to ask for our free clutch installation manual!

914-6 Clutch Package
... [R914 116 000 00 \\$350.00](#)



914-6 Conversion Guide

Written by Dr. 914, this guide tells you what you are getting yourself into when converting your four cylinder to a six. It also offers engine and suspension recommendations as well as wiring guides, parts lists and templates. A must for the six conversion.

Conversion Guide ... [BTC 1013 \\$16.50](#)

914-6 Muffler Bracket

Don't let your muffler hang loose! It will strain the heat exchanger to head connection and the resultant exhaust leaks and broken head studs will cause expensive damage! Replace that muffler bracket now with these factory fresh ones.

914-6 Muffler Bracket... [G039 251 067 \\$43.45](#)



HOW TO CONVERT A 914/4 TO A 914/6

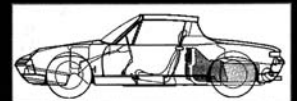

What you are getting yourself into.

by George A. Hussey IV

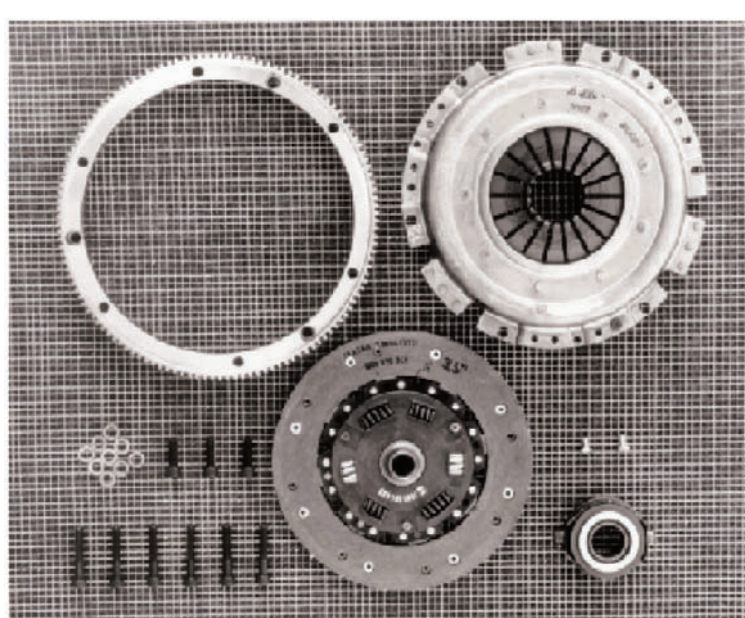

914-6 Clutch/Flywheel Conversion Package

When installing any six cylinder engine larger than 2.7, and retaining the 901 style gearbox, it is necessary to convert the clutch assembly to adapt from one to the other. This kit accomplishes that goal beautifully and inexpensively. Precisely machined parts will handle gobs of horsepower.

Conversion Package ... [RKEP 9146 \\$750.75](#)



Blower & Heater Hoses for your 914-6

These long-lasting aircraft quality heater hoses conduct only the hottest heat to the front of your 914, while providing flex during engine movement! Fit in between the heater control valve and the body. Order 4 hose clamps as well!

The blower hose is sold in a length of 44 in. and works for both the blower and front ventilation system.

Blower Hose, 3' Length ... [R911 211 522 00 \\$29.64](#)

Heater Control Valve Hose ... [R914 572 154 10 \\$14.50](#)

Heater Hose Clamps ... [R111 501 159 B \\$5.45](#)

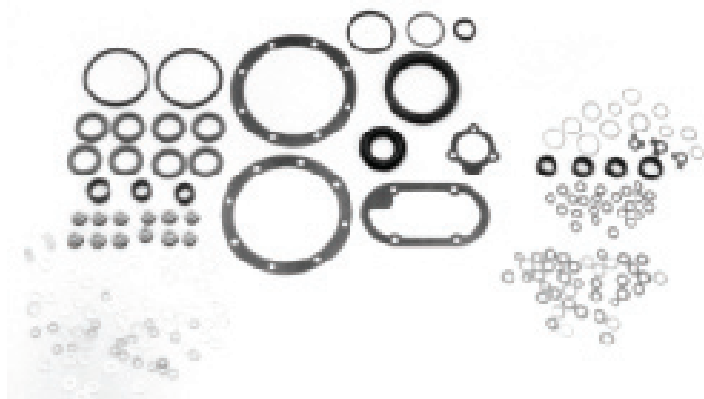

Engine Gasket Kit 914-6

You cannot rebuild without this critical kit! Every gasket and seal you could imagine for a thorough job. Other kits available for larger engine displacements.

Engine Gasket Kit ... [R901 100 902 03 \\$325.71](#)

G = Genuine • R = Aftermarket / Replacement •
U = Used • B = Rebuilt or Reproduction

ENGINE 914

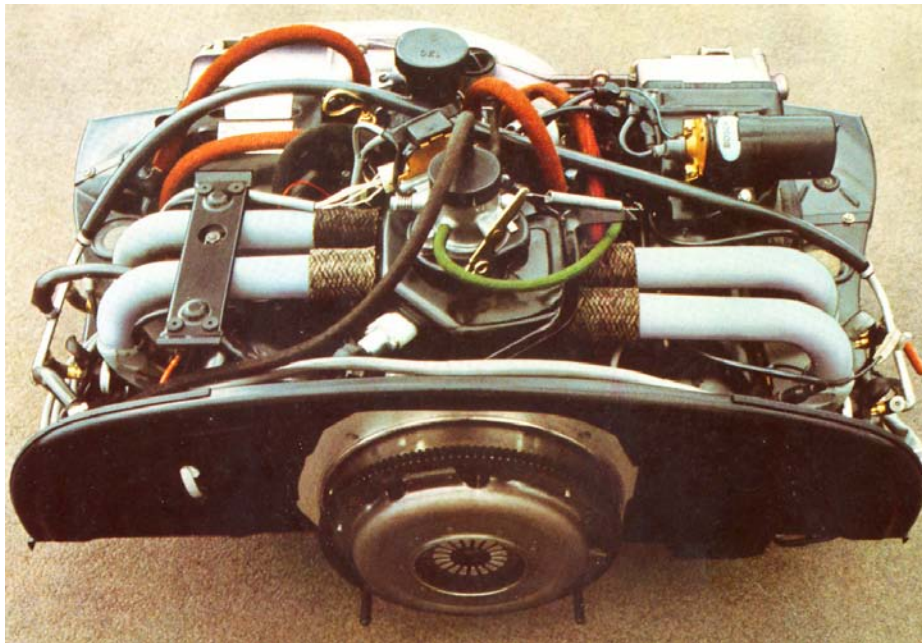

REBUILT 914 ENGINES

Our remanufactured engines are completely dismantled and meticulously cleaned. We replace camshaft, lifters, pistons, cylinders, valves, gaskets, bearings and seals. We also make certain that our engines will perform as close to new as possible. We then refinish all sheet metal and test run, break in the camshaft and then change the oil. All engines are ready to bolt to your transmission. Rebuilt engines have our six-month/six-thousand mile warranty which covers all internal moving parts. We also sell used engines! Please inquire.

1.7 Remanufactured Engine ... [B021 100 027 \\$5,500.00](#)

1.8 Remanufactured Engine ... [B022 100 027 \\$6,500.00](#)

2.0 Remanufactured Engine ... [B039 100 027 \\$7,150.00](#)

Plus Core Exchange of \$2,000.00 (same displacement engine)

• Please call for high performance applications •

Cleaned, Inspected, Aligned-Bored, Checked Case

When rebuilding, one of the most important things to start with is a clean and true engine case. Over the years many cases have warped internally, causing excessive friction, poor oil pressure, and/or a hot running engine. Don't take a chance, start with something thoroughly checked and align bored. Cases are sold on an exchange basis only. \$200.00 core charge.

Align-Bored Case (specify engine) ... [U021 101 025H \\$650.00](#)



Oil Temp Sending Unit

When adding a temperature gauge, this handy kit will make installation simple! Your engine block is already machined for direct bolt-in, and the sending unit is matched to your engine's operating temperature.

Sending Unit Cover

... [G039 101 267 \\$74.12](#)

Sending Unit for Factory Gauge

... [G039 919 268 \\$57.04](#)

Sending Unit for Aftermarket VDO

Gauge ... [RVDO 323 055 \\$17.32](#)

Cover Seal ... [R021 101 269A \\$6.88](#)



Engine Mounts

If your 73-76 shifter jumps when you are first starting off, chances are that your engine mounts are broken. These are the round rubber hockey puck looking rubber mounts between the engine and the engine mounting bar. Easily replaced after removing the oil filter and using a quarter inch drive ratchet with a 13mm socket, order two as even if only one is broken the other is soon to follow.

Engine Mount, 70-72 ... [R911 375 043 07 \\$62.75](#)

Engine Mount, 73-76 ... [R039 199 231 \\$23.84](#)

Engine Mount, 914-6 ... [G914 375 026 00 \\$164.06](#)

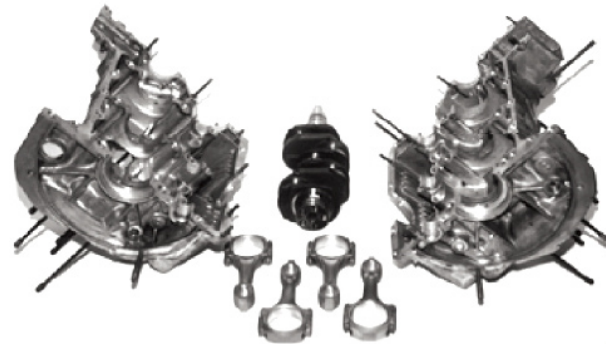

Engine Gasket Kit

You can't rebuild without an engine gasket kit, even if you are reusing the hard parts! Remember in addition to order four baffle plate seals, a front and a rear main seal and maybe a couple of CV joint gaskets!

1.7 Liter Gasket Kit ... [R021 198 009 D \\$52.50](#)

1.8 Liter Gasket Kit ... [R029 198 009 \\$57.75](#)

2.0 Liter Gasket Kit ... [R039 198 009 \\$76.99](#)

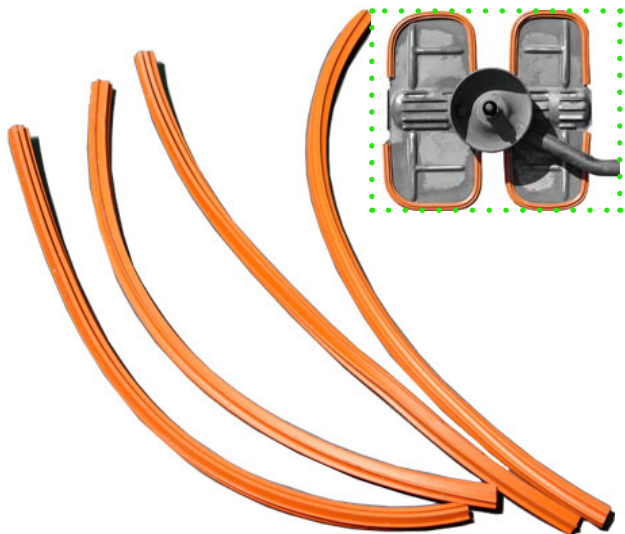

Oil Baffle Plate Seal

One of the most required and necessary-to-replace parts in any 914 engine rebuild. This plate is the seal that fits the baffle windage tray into the bottom of the engine case. Super high-temperature made from that latest silicone rubber technology.

Oil Baffle Plate Seal, 4 req'd ... [B022 101 559 \\$7.50](#)



SEAL THE CASE

Loctite

Recommended by the factory for the tightest, leak-free sealing!

Loctite ... RGR 3428 \$16.45

Main Seals

Front Main Seal - The strange leak coming down the center of the front of the 914 engine is this seal. Easily replaced after removing the front fan and front engine sheet metal, it is also a good time to install a new alternator belt.

Front Main Seal... [R021 105 247A \\$7.95](#)

Rear Main Seal - Easily installed especially when doing a clutch job, make sure you check the crankshaft end play and have the appropriate three shims in place.

Rear Main Seal... [R029 105 245B \\$15.95](#)



Engine Mounting Hardware

Wondering where to get the proper nuts and bolts to fix that bent engine mounting bar? It's here, and of the exact size for a perfect repair. No more fumbling for mismatched US sized nuts and bolts.

- | | |
|---|--|
| 1. 70-72 Inner Mount Bolt
... R900 074 138 01 \$2.36 | 6. Outboard Locking Nut (4 req.)
... R900 125 11 \$1.16 |
| 2. 70-72 Outer Mount Bolt
... R900 074 181 02 \$2.30 | 7. Outboard Washer
... B914 375 162 00 \$1.00 |
| 3. Washer
... R900 025 008 02 \$1.00 | 8. Outboard Bolt
... R900 075 085 02 \$1.16 |
| 4. Locking Nut
... R900 276 006 02 \$1.16 | 9. 73-76 Outboard Solid Mount
... G914 375 181 00 \$32.50 |
| 5. 73-76 Engine Bar Bolt
... RN104 723 \$2.31 | |



ENGINE 914

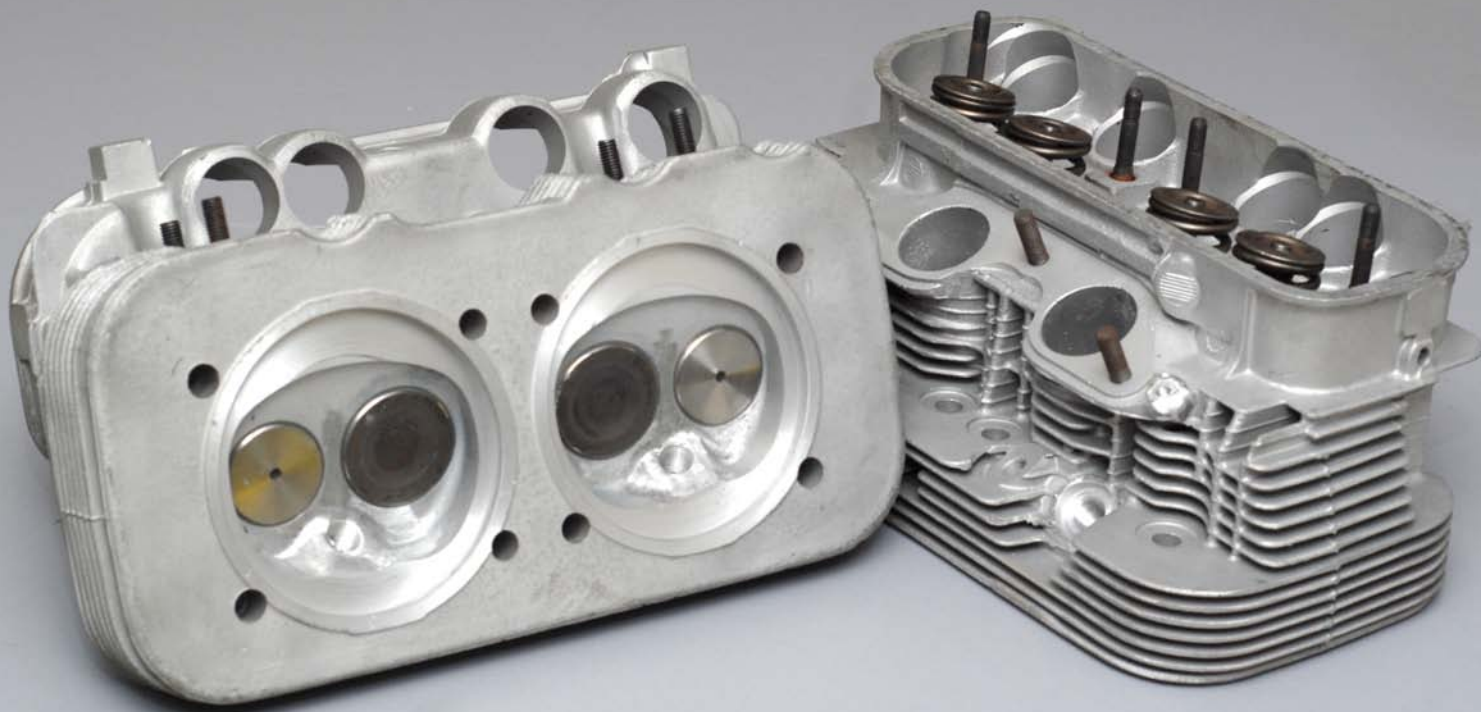

Cylinder Heads

Beautiful rebuilt or new cylinder heads available for 1.7, 1.8, and 2.0 liter displacement. Core charge of \$500. Specify driver or passenger side.

- 1.7 liter ... [B021 101 351B \\$700.00 Rebuilt](#)
- 1.8 liter ... [B021 101 351S \\$850.00 Rebuilt](#)
- 2.0 liter ... [B039 101 351E \\$950.00 Rebuilt](#)
- 1.8 Liter ... [R022 101 061 H \\$495.00 New](#)

Head to Heat Exchanger Oversize Studs

The bigger the stud the better is not necessarily true ... but a stripped exhaust stud hole sure makes the big studs look good.

- 1. 8/8mm stock 1.7 / 2.0 ... [RN143 979 \\$4.62 \(stock\)](#)
- 2. 8/9mm stock 1.8 or stripped 1.7 or 2.0 ... [RN146 979 \\$5.78](#)
- 3. 8/10mm stripped 1.8 or badly stripped 1.7 / 2.0 ... [RN146 841 \\$6.93](#)

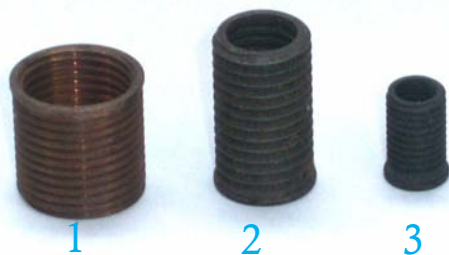

- 1. Spark Plug Insert ... [RTL 6001 \\$8.08](#)
- 2. Speedo Drive Set Screw Insert ... [RTL 6003 \\$8.08](#)
- 3. Shifter Set Screw Insert ... [RTL 6002 \\$8.08](#)



Inserts to Repair Shift Set Screw, Head Studs, Spark Plug Holes

Don't fret a stripped stud any longer. We found the parts to execute a perfect repair at home. Inserts are easily installed and make the threads new again.



BIG-BORE Piston & Cylinder Kits!

These instantly increase the horsepower of your 1.7, 1.8, or 2.0 while renewing the rings, pistons, cylinders, and wrist pins at the same time! We have installed many of these kits at our shop and found the quality and durability to be great! Our European 8.0 to 1 compression piston and cylinder kit gives 2.0 owners added zip while keeping displacement legal for racing events.

- 1.7 Engine ... [R021 198 075 96 \\$495.00](#)
- 1.8 Engine ... [R021 198 075 A96 \\$550.00](#)

Stock Piston & Cylinder Kits

- 2.0 Engine ... [R039 198 075 A96 0 \\$850.00](#)
- 2.0 Engine 8.0 Compression Factory 94mm European P&C Kit ... [R039 198 075 \\$850.00](#)

Rebuilt and Balanced 914 Crank

When rebuilding, the deepest part of the engine always needs special attention. A precisely matching, crack-checked and balanced crank is the solution for the highest oil pressure, least vibration and longest life. Order matched bearings for a precise fit. Core Charge \$250.00

- Crankshaft 2.0 ... [B039 105 101 \\$275.00](#)
- Crankshaft 1.7/1.8 ... [B021 105 101 \\$275.00](#)
- Counter Balanced 1.7, 1.8 Crankshaft for higher RPM (New, outright) ... [B021 105 101 CB \\$750.00](#)



Matched, Weighed And Rebushed Rod Set

Often overlooked in a rebuild, worn rod bushings or an absent rod will cause vibration and/or engine noise. Our precisely balanced and rebushed set eliminates the gamble and insures long life to your rebuild. Sold on an exchange basis only. Core charge \$200.00

- 1.7, 1.8 Rod Set ... [B022 105 401S \\$200.00](#)
- 2.0 Rod Set ... [B039 105 401S \\$275.00](#)



Align Bore Bearings

Wonder why your rebuilt engine runs hot and rattles? You forgot to align bore the warped case! Bearings are available in oversize for both the crank and the case side of the bearing. See standard bearings on page 220.

- Standard Crank/.50 Case ... [R021 198 482OR \\$95.84](#)
- .25 Crank/.50 Case ... [R021 198 484OR \\$105.19](#)
- .75 Crank/.50 Case ... [R021 198 488OR \\$105.19](#)

ENGINE 914



REMACHINED AND BALANCED FLYWHEEL

Flywheel out of balance? Clutch releasing too high or not at all? A poorly remachined flywheel could be the culprit. Our unit is precisely remachined, balanced and depth-gauged for perfection. Core charge \$100.00

Flywheel... B022 105 273A \$125.00

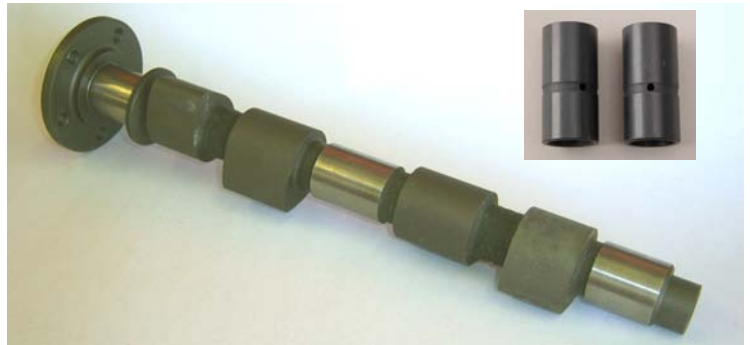

Viton Push Rod Tube Seal Kit

Who wants to constantly perform the dirty, greasy pushrod tube replacement procedure when these space age viton seals eliminate the problem for years! Rated at 450°, if installed properly you should never have to replace the seals again! Kit comes complete with precise instructions written by Dr. 914, and valve cover gaskets. Everything you need except hand cleaner! Consists of: 8 B021 109 349; 8 B021 109 345 A; 2 R021 101 481; 1 RTC 1022 Make sure that you readjust the valves and check the valve adjuster lugs for damage.

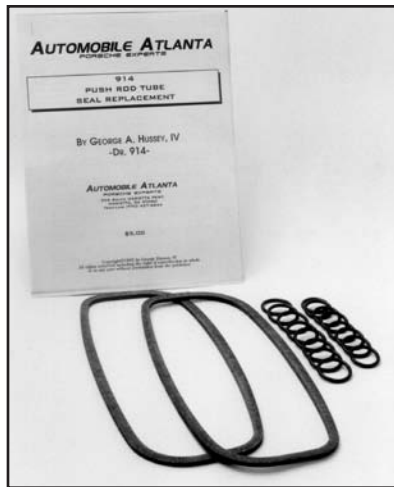

Viton Pushrod Tube Seal Kit
... [R914PRT \\$21.94](#)

Scatcam For Carbs

When you build a performance engine for your 914 and add carbs, the high performance camshaft is a must! It will increase high RPM power for faster acceleration. Cut from a new billet, it will last the life of your engine. (Whenever replacing the cam you need to replace the lifters, so include the set listed below!)

For Single Carbs ... [RMIS 136 \\$135.00](#)

For Dual Carbs ... [RMIS 137 \\$135.00](#)

Scat Lifter Set For Carbs

Scat lifters for the scat cam are required as the hardness of both parts are matched. Do not use any other.

Lifter Set (8) ... [RMIS 138 \\$92.40](#)



Swivel Foot For Rocker Arms

Installing 911 swivels on your 1970-73 914 will result in more precise valve adjustments and a quieter engine. Swivels keep precise contact between the foot and valve stem for reduced wear as well. If installing on 1974-76 models, the rocker arms will have to be replaced with the earlier 1970-73 style.

Swivel Feet ... [R911 105 370 02 \\$7.50 each \(8 req'd\)](#)

Oil Strainer Kit

Don't be without this item when changing the oil. Too many replace the filter but don't clean the strainer, resulting in dirtier oil long before its time.

Oil Strainer Gasket Kit

... [R021 198 031 \\$4.04](#)

Oil Strainer Basket

... [R021 115 175 \\$15.55](#)

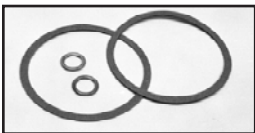

Pushrod Tubes

Beautiful cad plated new pushrod tubes finally seal the leak! Make sure you install a set of our high temperature viton seals and readjust the valves as well as inspect the valve adjusting lugs. Easily installed just by removing the rocker arm assemblies.

Pushrod Tubes ... [R021 109 335C \\$9.90](#)



Deep Sump

In a hard corner, the 914 often loses top end oil pressure. Easily bolted on, the deep sump assures longer engine life and increased engine lubrication. The deep sump is a must for slalom events, as it adds almost two quarts of additional oil.

Deep Sump ... [RMIS 300 \\$173.25](#)



Moly Lube Oil

For the ultimate in synthetic protection. 5 liter container is more than enough for an oil change!

Swepeco Moly Lube
... [RGR676 \\$13.14](#)



Oil Filter

How about an oil filter while you are at it?

914 Oil Filter
... [R021 115 351 A \\$10.79](#)

Parts that are replacement, used or reproduction are not approved, guaranteed, or warranted by Porsche; use of unapproved parts may negate the factory warranty, or alter safety, emission, aerodynamics, or fuel consumption characteristics.



Heavy Duty Oil Pump

Our high volume oil pump increases capacity by 40%; providing a cooler, longer lasting engine in high performance situations. Complete with gasket.

Heavy Duty Oil Pump ... [RM79 AHV \\$86.84](#)



Oil Temp Sender

An exact temperature match for the factory 914 gauge.

Oil Temp Sender
... [G039 919 268 \\$57.04](#)



VDO Oil Pressure Hose Kit

The oil pressure sending kit consists of everything you need to install the dual (gauge and warning light) sending unit on your Porsche engine. This unit is a must for high performance applications where oil pressure monitoring is critical.

Oil Pressure Hose Kit ... [VDO150 752 \\$37.95](#)

ENGINE 914



Engine Oil Drain Valve

Changing oil used to be a messy job! No more dropped oil plugs and red-hot oil dripping down your arm. Just release the safety latch and press the lever; the oil drains neatly in seconds, without a mess. The stainless steel valve work is unaffected by road weathering. Approved by world auto manufacturers. Recommended by many do-it-yourself mechanics!

914 70-76 Oil Change Valve ... [RMB 241 70 \\$23.93](#)

914-6 70-72 Oil Change Valve ... [RMB 241 71 \\$31.85](#)

1.8 Oil Cap Seals

Round oil cap o-ring that fits onto the upper part of the cap. Critical for proper fuel injection operation.

1.8 Oil Cap Seal, Round ... [R022 115 331 \\$9.69](#)

1.8 Oil Cap Seal, Flat ... [R022 115 315 \\$9.50](#)



Oil Cooler Seal Kit

We used to think that oil cooler seals never leak, but that was then and this is now. Your mechanic has now told you the engine needs removal to replace these seals and wants to charge you an outrageous price. No way! Do it yourself in 15 minutes with our kit without removing the engine and embarrass your mechanic. Consists of:

Replacement Procedure ... [BTC 1019 \\$6.60](#)

Oil Cooler Seals, 2 Req'd ... [R021 117 151A \\$2.88](#)

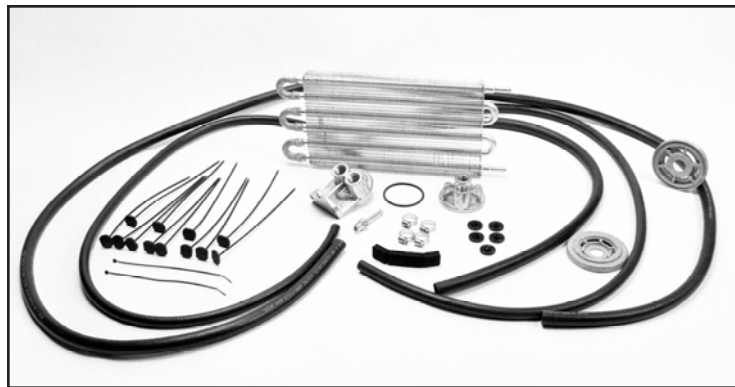
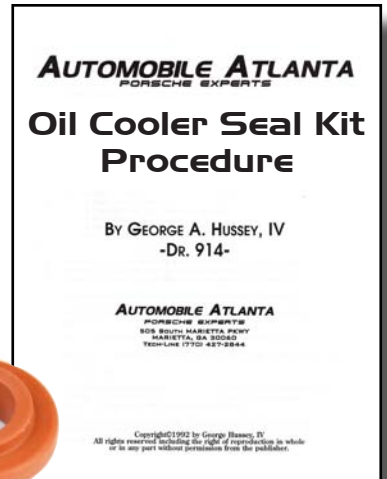

Oil Cooler Kit For Track Events

When running your high performance 914-4 engine at the track at high RPM, an auxiliary oil cooler is a must. Easily installed and located to the passenger side of the transmission, this cooler will reduce oil temperatures to a reasonable level on the hottest day at the highest RPM.

Auxiliary Oil Cooler ... [B901 107 000 00 \\$150.00](#)



Sheet Metal Screw Kit

Have you lost your engine sheet metal screws and can't find the substitutes? You'll need many of these screws when rebuilding, as lost and broken screws are common. These shiny, plated screws also dress up your rebuild.

Sheet Metal Screw, Each ... [GN014 139 57 \\$1.10](#)

Sheet Metal Screws, Set of 20 ... [GN 014 139 57S \\$20.90](#)



Timing Hole Plug

Long discontinued by the factory, this exact reproduction screws perfectly into the impeller housing and plugs a large hole, vital to increasing air flow.

Timing Hole Plug ... [B021 119 233A \\$19.50](#)

Wurth Zinc Spray Paint

13.5 Oz (400ml). 98% pure zinc. This is the ultimate muffler, heat exchanger, and intake runner paint that matches the factory color, and is resistant to heat, sand, and water. Also perfect for sealing welded seams in restoration projects. Dries in 15 minutes.

Wurth Zinc Spray Paint ... [RGR1012 \\$28.60](#)



Grommets and Boots

Boots and grommets for every occasion. Did you know that these were still available? The perfect protection and the perfect touch for your perfect 914.



1. Turn Signal Boot ... [G914 631 217 10 \\$28.78](#)
2. Starter Lead Boot ... [G999 659 006 50 \\$6.50](#)
3. Front Panel Plug ... [G914 559 252 10 \\$19.00](#)
8. Horn Boot ... [G901 347 823 01 \\$12.71](#)
4. Reverse Light Boot ... [G914 613 491 00 \\$11.02](#)
5. Fuel Line/Brake Line Boot ... [G111 957 861 \\$6.50](#)
6. 914-6 Ign. Control Unit Boot ... [G930 612 914 00 \\$69.52](#)
7. 914-4 Oil Pressure Switch Boot ... [G021 119 957 \\$12.44](#)
8. Sheet Metal Grommet/Accelerator Cable Grommet ... [G021 119 553 \\$8.38](#)
9. J Pipe Grommet ... [G021 119 627B \\$14.95](#)
10. Fuel Pump Boot ... [G311 906 101 \\$18.15](#)
11. Head Temperature Sensor Grommet ... [G021 119 569 \\$19.07](#)
12. Engine Lid/Front Trunk Floor Buffer ... [G914 559 253 10 \\$29.50](#)
13. Headlight Eyebrow Grommet ... [G914 750 197 10 \\$4.91](#)
14. Heater Control Cable Boot ... [G113 711 691 \\$4.50](#)
15. Rear License Plate Light Wire Plug ... [G111 971 911A \\$9.50](#)
16. License Plate Bracket Buffer (2 req'd) ... [G803 955 637 \\$5.58](#)

Air Guide Plate

Beautiful repros of the no longer available left 1975-76 and 1973-74, air guide plates are finally available. A must for cooling, air guide plates are the ones that go in between the engine block and the heat exchangers. So that's what goes there, you say! 1. and 3. pictured.

1. Air Guide Plate, 1973-74, Left ... [B022 119 356A \\$63.80](#)
2. Air Guide Plate, 1970-74, Right ... [B022 119 356A \\$63.80](#)
3. Air Guide Plate, 1975-76, Left ... [B022 119 356A \\$63.80](#)
4. Air Guide Plate, 1975-76, Right ... [B022 119 356A \\$63.80](#)

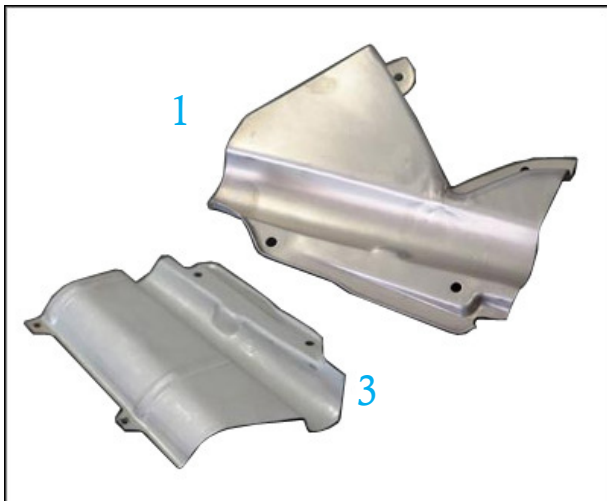

Thermostat Bellows & Parts

Too many have removed the thermostat assembly in error, causing premature engine wear as the engine does not reach operating temperature soon enough. Renew the required factory arrangement today with our handy kit.

- Cable ... [G021 119 751 \\$8.50](#)
- Bracket ... [G022 119 155 \\$32.37](#)
- Cable Seal ... [G021 119 955 \\$2.25](#)
- Thermostat Bellows ... [G021 119 159 A \\$82.50](#)

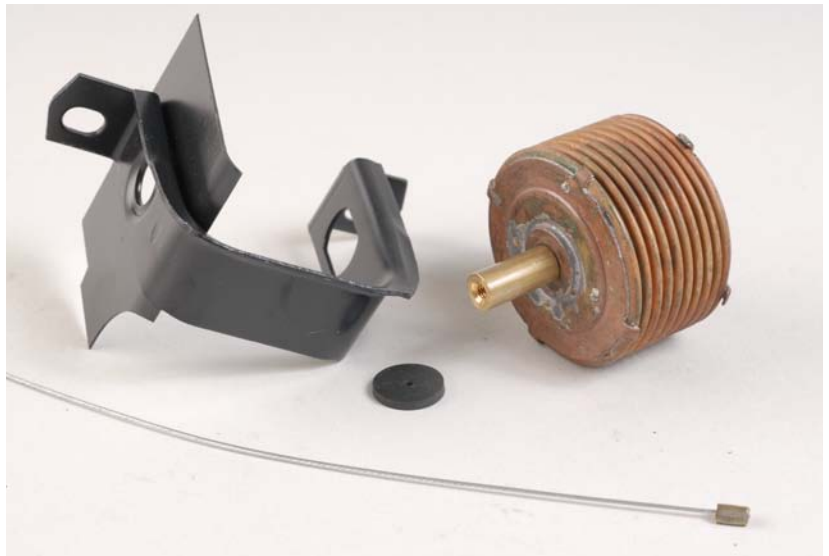

ENGINE 914

WEBER™ CARBURETOR KITS

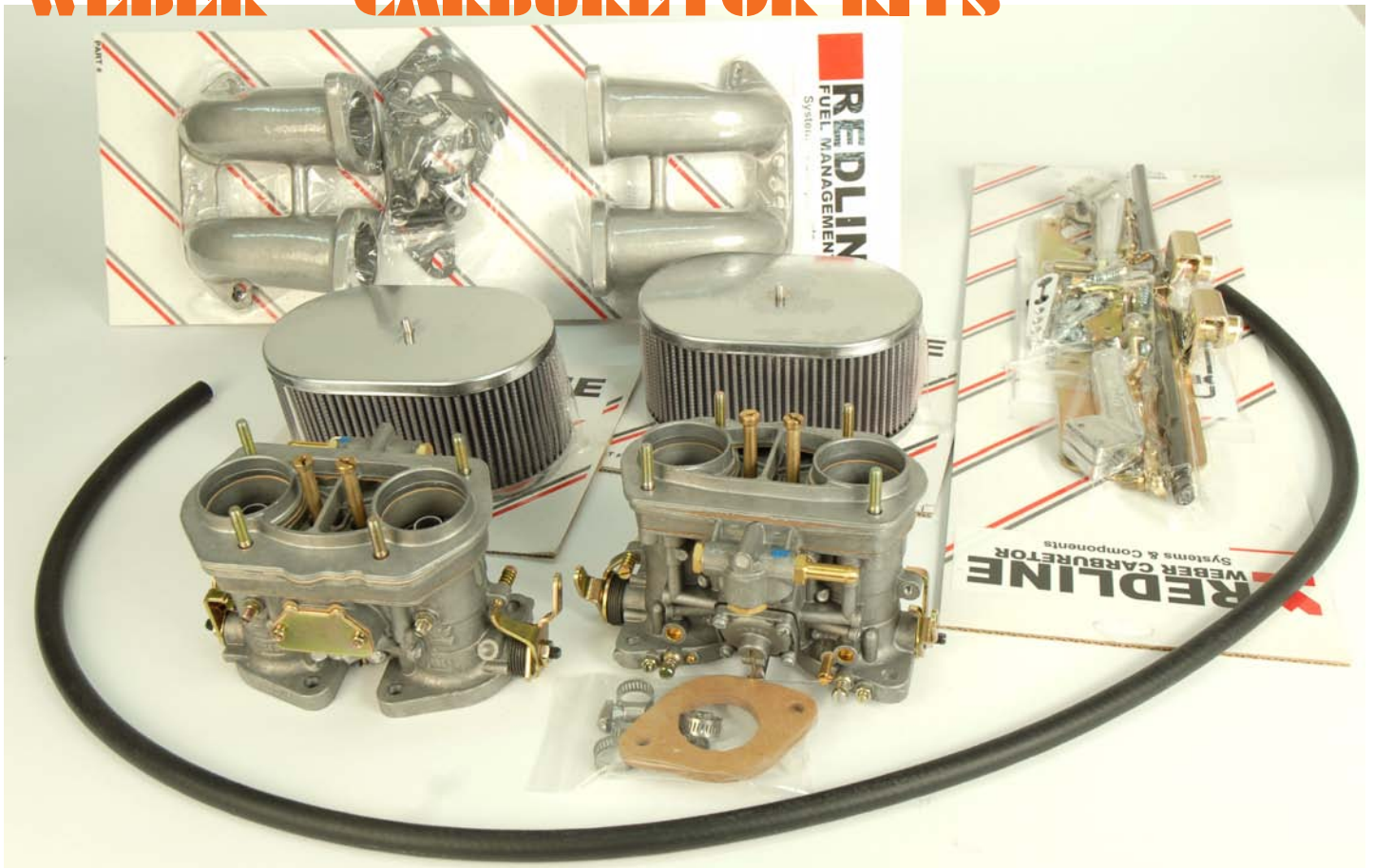

If you are building a high performance 914 engine or have had an engine fire, carburetion is for you! Our single carb set provides good performance, warm-up, and fuel economy at a reasonable price. Our dual set provides increased performance and reasonable economy. Both should be ordered with a Facet fuel pump and .009 distributor. If you have to carburate, Weber is the best!

Single Carb Set ... [RMIS WEB TB 300 \\$456.22](#)

Dual Carb Set ... [RMIS WEB TB 200 \\$1,045.00](#)

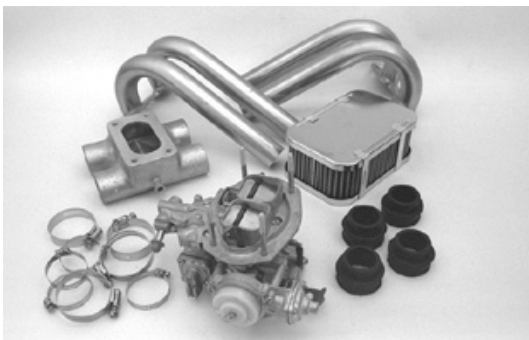

Deluxe Carburetor Linkage Kit

The dual carburetor cross bar linkage updates the old pivot and rod setup and provides very smooth positive accelerator action. Our dual carb sets include this linkage.

Deluxe Carburetor Linkage Kit ... [RWEB100 \\$176.00](#)

[770-427-2844](#) or [800-792-4944](#)

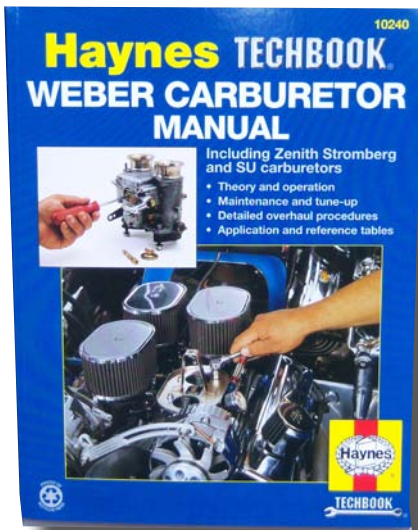

Weber Carb Book

Everything you ever wanted to know about Weber carbs and a lot you didn't want to know! We receive hundreds of calls each year about tuning and overhaul of Weber carbs, and although we do not prefer them on 914 fours, this book certainly makes tuning and maintenance look easy! A must for the 914-6 owner!

Weber Carb Book ... [RBK 10240 \\$24.15](#)

K&N Air Filter For High Performance

Increase air flow 30% and never replace the air filter again! Permanent washable K&N filters are just right for the road racer in you! Install one and notice the difference immediately. Order cleaner and lubricant listed on next page.

914-6 1970-72 ... [RE2380 \\$52.95](#)

914-4 1974-76 ... [R332003 \\$47.95](#)



Carb Air Filters, Assemblies and Stock Air Filters

All 914-6 models and 73-76 914s need new air filters; we make it easy with these fresh German replacements. Way too many air filter assemblies were fitted to dual and single carb kits. Who knows what is on yours? Straighten it out with our permanent, washable air filters and highly chromed frames. Nothing looks better in a carbureted engine bay than a pair or a single shiny new air filter assembly.

73 914 1.7 ... [R022 129 620 \\$14.44](#)

73-76 914 ... [R039 129 620A \\$11.55](#)

70-72 914-6 ... [R901 108 955 11 \\$23.10](#)

Single Carb (Element only) washable

... [R994 002 91 \\$22.52](#)

Dual Carb (Element only) washable, 2 required

... [R994 004 04 \\$22.52](#)

Dual Carb Filter Assembly, 2 required

... [R992 173 47 \\$45.62](#)

Single Carb Filter Assembly

... [R992 173 31 \\$40.42](#)



Carburetor Rebuild Kits

Any carburetor that has sat around dry for a few months needs a rebuild (unfortunately). Our carb kits have everything for a perfect repair by the home hobbyist.

Single Weber Carburetor Rebuild Kit

Carburetor Kit 914-4 Single ... [RWP9 232 3705 \\$40.42](#)

Dual Weber Carburetor Rebuild Kit

Carburetor Kit 914-4 Dual (Two Req'd)
... [RWP 9232 4005 \\$40.42](#)

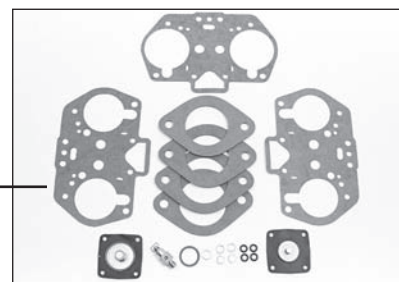
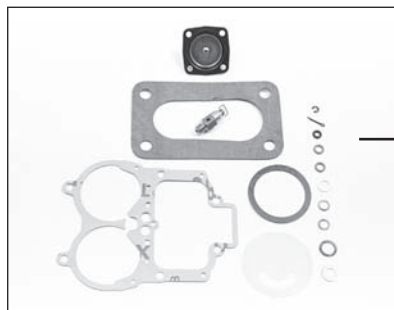

ENGINE 914



2.0 Model Shown

MSDS HIGH FLOW CONE FILTER

This high flow cone filter attachment is the perfect addition to a tired engine and adds color to your engine bay. Gain up to 10 hp over the restrictive stock setup and it installs in just a few minutes with basic hand tools! A great upgrade for a stock or modified engine.

1970-73 1.7 ... [BMSDSFLOW2 \\$129.95](#)

1973-76 2.0 ... [BMSDSFLOW3 \\$129.95](#)

1974-75 1.8 ... [BMSDSFLOW \\$129.95](#)

K&N Air Filter

These high quality filters improve performance, while saving you money. Unique design adds power. They replace the standard filter element and are very low restriction, improving engine breathing. Because they allow more air into your engine, the result is more power along with improved fuel economy. You'll never buy another filter for your vehicle once you install the K&N. When the filter does become dirty, simply take it out and wash it, re-oil it and use it again. Each K&N filter comes with a one million mile warranty.

K&N Air Filter, 914-6 ... [RE2380 \\$52.95](#)

K&N Air Filter, 914-4 ... [R332003 \\$47.95](#)



Make sure you are on our emailing list to get the latest specials and savings! Simply email your name to info@autoatlanta.com.



K&N Air Filter Recharger Kit

12 oz. cleaner and 6.5 oz. filter oil. Completely restore your K&N filter's air flow efficiency so that it will perform like new!

K&N Air Filter Recharger Kit

... [R995 050 \\$13.16](#)

G = Genuine • R = Aftermarket / Replacement •
U = Used • B = Rebuilt or Reproduction



Vacuum Line Kit

Our vacuum line kits solve the lean running, poor performance, and high/low idle caused by vacuum leaks! Custom cut, colorful, and easy to install, new vacuum lines also dress up your engine compartment! Kit comes complete with vacuum cartoon for easy installation.

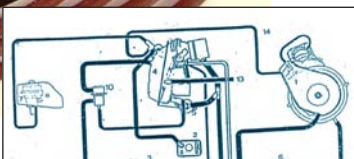

Vacuum Line Kit, 1.7 ... [BAAVACKIT1 \\$74.80](#)

Vacuum Line Kit, 1.8 ... [BAAVACKIT2 \\$74.80](#)

Vacuum Line Kit, 2.0 ... [BAAVACKIT3 \\$74.80](#)



Stacked, Branch, Standard, Vacuum Elbows

"Hey Dr. 914, why is my idle so high?"

1. 1.8 Elbow ... [G021 129 637F \\$5.24](#)

2. Standard Elbow All ... [R022 129 637 \\$8.50](#)

3. Branch Elbow 1.7 ... [G022 133 083 \\$9.50](#)

4. Stacked Elbow Early 1.7 and '73-74 2.0 ... [B022 129 637B \\$20.00](#)

Rebuilt Auxiliary Air Valve, Rebuilt Injectors, Pressure Sensor, Airflow Meter, & Control Unit - Save Hundreds!

Our rebuilt fuel injection components are the highest quality available and replace no longer available parts. Your 914 fuel injection can again operate as it should for snappy performance, great gas mileage, and long engine life. Please return your cores!

1. 1970-74 914 Fuel Pump ... [B311 906 091 \\$185.00](#)

1. 1970-74 914 Fuel Pump

... [B311 906 091 D \\$185.00](#)

2. 1975-76 914 Fuel Pump ... [B043 906 091 \\$159.50](#)

3. 1974 1.8 Air Flow Meter ... [B022 906 301 \\$195.00](#)

3. 1975 1.8 Air Flow Meter ... [B473 906 301 \\$195.00](#)

4. 1.7 Pressure Sensor ... [B022 906 051E \\$275.00](#)

4. 1973-76 2.0 Pressure Sensor ... [B039 906 051 \\$275.00](#)

5. 1970-76 1.7, 2.0 Aux Air Valve ... [B022 906 045 \\$159.50](#)

6. Cylinder Head Temp Sensor ... [R311 906 041 A \\$30.20](#)

7. 1973-74 2.0 Injector ... [B039 906 031 \\$75.00](#)



7. 1975-76 2.0 Injector ... [B039 906 031A \\$75.00](#)

8. 1.7 Injector ... [B022 906 031A \\$47.00](#)

1.7 Control Unit ... [B022 906 021B \\$495.00](#)

1973-74 2.0 Control Unit ... [B039 906 021 \\$495.00](#)

1.8 Control Unit ... [B473 906 021 \\$495.00](#)

1975-76 2.0 Control Unit ... [B039 906 021A \\$495.00](#)

1974-75 1.8 Aux Air Valve ... [B022 906 045A \\$275.00](#)

1.8 Injector ... [B022 906 031C \\$47.00](#)

1.7 Air Cleaner Wing Nut

Never available as a separate piece from the factory, it seems that more of these are lost than we would ever like. This exact reproduction passes the concours judges' approval and well-secures your air filter assembly.

Air Cleaner Wing Nut ... [BN160600 \\$10.45](#)

We have a limited supply of plastic factory 1.7 air filter housings. Please inquire.

ENGINE 914



Fuel Rail Kit

Ever wonder why all of the new Porsches have a big fat fuel rail? Because it keeps the injectors fed! The original fuel injection system factory installed on 914s was barbaric by today's standards. Bosch has learned so much since, that to employ some of the new technology to the old beast could only be beneficial. Our fuel rail set with built in VDO fuel pressure monitor will both supply the injectors with a more constant supply of fuel while helping to reduce the chronic vapor lock. You racers will also love the high rpm power increase. The kit is cut from high quality billet aluminum to exacting standards and perfectly fits all 1.7, 1.8 and 2.0 model engines. Easily installed by even the least talented back yard mechanic, you will love the results! Comes complete with gauge.

Fuel Rail Kit ... [RMB23951 \\$192.50](#)

Hot Fuel Injection Setup

Why not install the secret factory setup on your 914 1.7 or 2.0? It will increase top end performance and is factory authorized! This special pressure sensor and head temperature resistor, once installed, will give a noticeable increase in top end power and still pass current emissions standards.

Hot Setup Kit ... [B914 HSK \\$269.50](#)

Head Temp Resistor Only... [G039 971 762A \\$37.88](#)

(Core charge on pressure sensor)

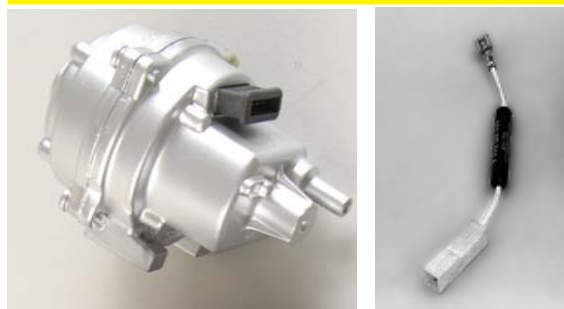

Throttle Return Spring and Barrel Nut Bolt For Throttle Body

A sticking or loose accelerator cable is most annoying! Solve it with these parts and a little lubrication.

Throttle Spring ... [B022 129 881F \\$8.35](#)

Barrel Bolt ... [R111 129 921 \\$9.49](#)



Fuel Injector Elbows

The perfect curve! Ever try to connect the 914 fuel injector to the fuel rail with regular hose? If so, you know that pinched, ragged hose pieces just don't cut it (so to speak!). These beautifully curved reproductions exactly replace the line while providing great ease of installation.

Fuel Injector Elbows ... [B043 133 387 \\$9.50/each](#)



HOT NEW FUEL INJECTION KIT

An Auto Atlanta Exclusive!

This is the system that gives your engine that full on competition look and the performance to go with it. Power gain from stock 90 HP to 125 HP. The fuel injectors and custom ribbed fuel rails are highly visible in their outboard location. Extreme Fuel Injection is the perfect upgrade for a meager 914 engine. The biggest performance limiter was the 914's intake plenum. Its small size starved this engine of air and did not allow for aggressive fuel injection or higher compression. Our kit provides plenty of air flow! Each kit is shipped with 48mm throttle bodies, injectors, fuel rails, manifolds, air filters, throttle linkage, computer, wiring harness, fuel pump, pressure regulator, threaded fuel rails, complete wiring, coil pack, instruction booklet and, last but not least, our exclusive, Automobile Atlanta crank fire distributor. Our kit is direct bolt-on done by the home hobbyist in about four hours.

Extreme Fuel Injection Kit ... [BMB31431 \\$2,950.00](#)



Our secret weapon: the Crankfire Distributor! (Included with Kit)

Upper Fuel Line Kit

In the early 1970s the factory authorized a recall of all 914s for replacement of the cloth covered upper fuel lines with high pressure rubber covered ones impervious to battery acid. Now you too can duplicate the factory procedure with this high pressure kit including the pre-bent injector elbows and special non-intrusive clamps.

Upper Fuel Line Kit ... [BAAA 133 000 \\$71.50](#)



Intake Boots

The cause of most vacuum leaks! Easily installed once the runner are removed. A great time to replace the large and small injector seals as well as paint the runners with some of our factory zinc paint!

Intake Boot, 1.7 ... [R022 133 241B \\$7.50](#)
 Intake Boot, 1.8 or 2.0 R039 133 241 \$7.50

Gasket Block For Intake Pipe

1.7 & 1.8. A necessity for sealing the intake runner tubes to the head and also to insure good insulation from the heat! Two required. Easily installed. Order the intake boots at the same time.

1. Gasket Block for Intake Pipe, 1.7 & 1.8 ... [R022 129 707 F \\$11.55](#)
 2. Gasket Block for Intake Pipe, 2.0 ... [R039 129 707 \\$11.55](#)



ENGINE 914

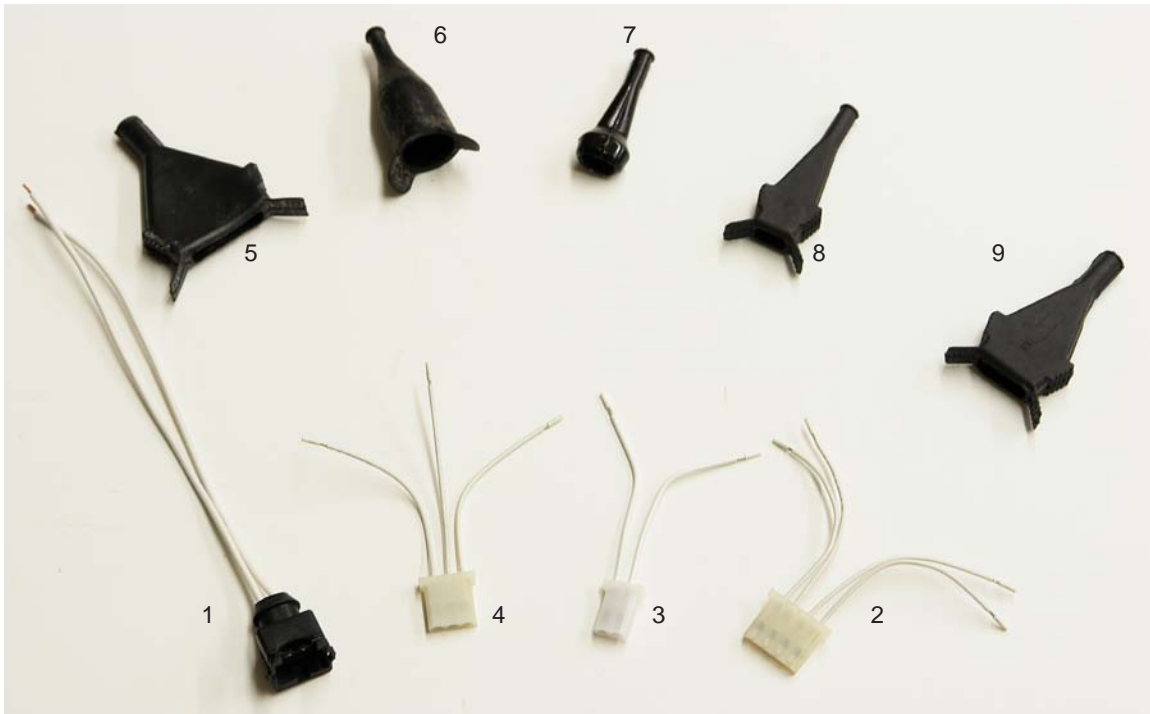

Injector Boot and Injector Lead Repair Kits

These days, if we can find a factory fuel injection harness in any condition it is a miracle. The only alternative is to repair your current one. Injector leads and boots make it as easy as soldering and heat shrinking. Available for both D Jetronic (MPC) and LJetriconic (AFC), these boots and leads make an undetectable repair.

- 1. 1.8 2-Pole Injector Lead ... [R553 91265 \\$17.32](#)
- 2. 1.7, 2.0 4-Pole Injector Lead ... [R553 9125 \\$17.32](#)
- 3. 1.7, 2.0 2-Pole Injector Lead ... [R553 9123 \\$17.32](#)
- 4. 1.7, 2.0 3-Pole Injector Lead ... [R553 9124 \\$16.50](#)
- 5. 4 Pole 1.7, 2.0 Boot ... [B311 906 102 C \\$12.00](#)
- 6. Fuel Pump Boot ... [G311 906 101 \\$18.15](#)
- 7. 1.8 Injector Boot ... [R022 990 610 2 \\$4.62](#)
- 8. 2 Pole 1.7, 2.0 Boot ... [R311 906 102 A \\$12.00](#)
- 9. 3 Pole 1.7, 2.0 Boot ... [R311 906 102 B \\$12.00](#)

Injector Pressure Sensor Boot Kit

Four injector boots and one pressure sensor boot and one throttle switch boot replace the most deteriorated harness boots for all 1.7 and 2.0 engines. (See 1.8 injector boots on page 209.)

- 6 Piece Kit ... [B311 906 102 \\$49.50 \(Includes 4 two-pole, 1 3-pole, & 1 four-pole\)](#)
- 2-Prong Boot ... [R311 906 102 A \\$12.00](#)
- 3-Prong Boot ... [R311 906 102 B \\$12.00](#)
- 4-Prong Boot ... [R311 906 102 C \\$12.00](#)
- 5-Prong Boot ... [R311 906 102 E \\$12.00](#)



Fuel Injector Cleaner

Removes deposits and residues from fuel distributors, injectors, and inlet valves. It eliminates problems such as hard starting, rough idle, and impaired drivability. Strong enough for fast cleaning of neglected fuel injection systems, and gentle enough for periodic use.

Jectron Lubro-Moly Fuel Injector Cleaner
... [RGR2007 \\$8.75](#)



Decel Valve

Pneumatic deceleration. Beautiful cad-plated replacement for this long discontinued part! USA, 1.7/1.8/2.0.

Decel Valve ... [G022 133 551B \\$198.00](#)



Zinc Spray

98% pure zinc. This is the ultimate muffler, heat exchanger, and intake runner paint that matches the factory color, and is resistant to heat, sand, and water. Also perfect for sealing welded seams in restoration projects. Dries in 15 minutes.

98% Zinc Spray ... [GR1012 \\$28.60](#)

Caps for Air Injection Tubes

Keep that exhaust leak from happening when you remove the stupid air injection pump! Four caps will do.

Caps for Air Injection Tubes ... [B021 131 285 \\$4.50/each](#)



1.7



1.8

INTAKE RUNNER BOOTS

At last, a quality replacement for this long-discontinued part! Solve the air leaks and restore the power!

Throttle Body Boot, 1.7 Liter

... [B021 129 967P \\$65.00](#)

Throttle Body Boot, 1.8 Liter

... [G022 129 967AA \\$78.78](#)

If you don't see it, call us! We probably have it anyway!

Bosch Fuel Injection Book



Finally! The authoritative manual on Bosch Fuel injection. This is the only book that fully explains all aspects of these Bosch systems: Motronic, L-Jetronic, LH-Jetronic, LH-Motronic, D-Jetronic, K-Jetronic, KE-Jetronic, and KE-Motronic. You will find specific information on the newest KE-Motronic and LH-Motronic systems that is not available from any other source.

Bosch Fuel Injection Book

... [BBOSCH \\$35.00](#)

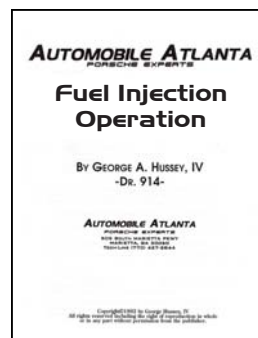

Fuel Injection Operation

Know nothing about 914 fuel injection and long for a quickie introduction? Our fuel injection operation guide gives you just that: basic working knowledge so you can begin to confidently deal with any fuel injection problem that may occur. Sure wish I had this handy guide available back in 1974 when my 914 stalled on the interstate!

Fuel Injection Operation

... [BTC 1016 \\$11.00](#)

ENGINE 914

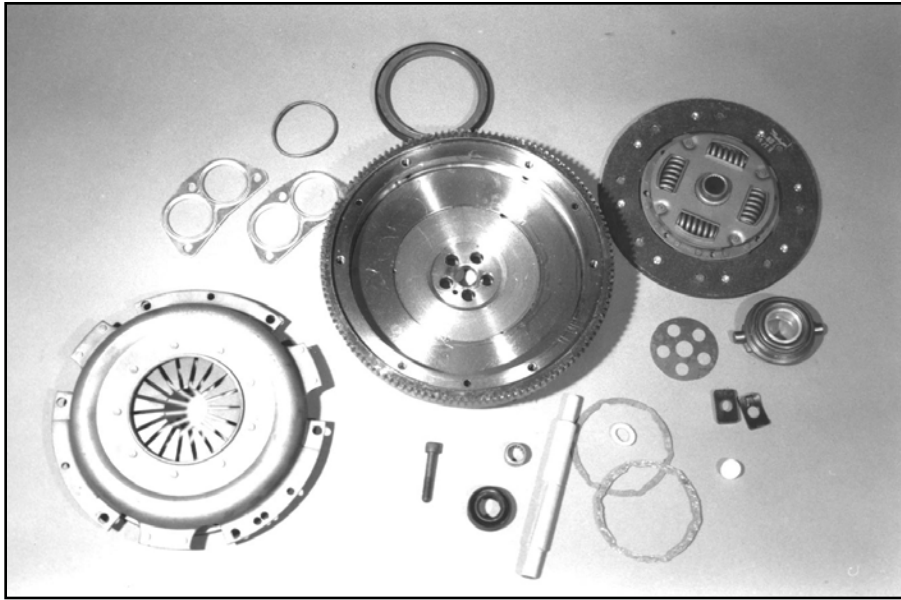

914 19-Piece Clutch Package Kit - New Flywheel, Rebuilt Plate & Disc

Our 19-piece clutch package contains everything we use in our shop for a perfect clutch replacement. Beware of lesser kits, you will need all of these parts! Included is the clutch installation manual. KIT INCLUDES: Rear main seal, Throwout bearing, 2 Throwout bearing clips, Flywheel (NEW), Front trans. seal, 2 CV joint gaskets, Flywheel O-ring, Ball stud cup, 2 Muffler gaskets, Needle bearing, CV joint bolt, Clutch alignment tool, Flywheel crush washer, Felt washer, Pressure plate (RBLT), Clutch disc (rblt.), clutch installation manual. CORE CHARGE \$100.

Clutch Package Kit, 3 Rebuilt Parts ... [B914 116 000 01 \\$456.23](#)

Clutch Package Kit, All New Parts ... [G914 116 000 01 \\$695.00](#)

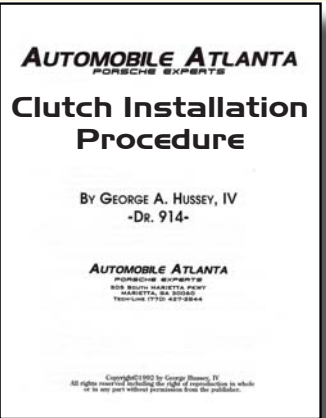

Clutch Installation Procedure

Try before you buy and find out what you are in for with our clutch installation manual (see how easy it is!). Price will be deducted from Clutch Kit Purchase.

Clutch Installation Procedure ... [BTC1007 \\$5.00](#)

High Performance Six Spring Disc

Extra grip for track events!

... [R914 116 011 01 \\$95.00](#)



Muffler Bracket

Don't let your muffler hang loose! It will strain the heat exchanger to head connection and the resultant exhaust leaks and broken head studs will cause expensive damage! Replace that muffler bracket now with these factory fresh ones.

1970-74 1.7, 1.8 ... [B021 251 067A \\$43.45](#)

1973-74 2.0 and 914-6 ... [B039 251 067 \\$43.45](#)

1975-76 914 all ... [G039 251 067A \\$64.04](#)

1975-76 Muffler Connector Pipe

Standard equipment on all 49 state 1975-76 914s, this high quality Bursch made pipe is necessary when replacing all 1975-76 exhaust systems. Make sure however yours needs replacement as these pipes rarely fail.

Muffler Connector Pipe ... [R039 251 058 \\$40.90](#)



770-427-2844 or 800-792-4944



Replacement Catalytic Converter

Attention California 914 owners! Replace that old plugged cat and realize increased power and lower emissions ... and all at a fraction of the original price! Comes with one year warranty.

Catalytic Converter Replacement ... [RB099 905 \\$195.77](#)

IF YOU DON'T SEE IT,
WE HAVE IT ANYWAY!
JUST CALL!

Bursch Muffler

Doug Bursch, an old Porsche racer from way back, was discontent with his factory muffler every time he raced. Having great design skill because of his engineering background, he designed a muffler that would suit his high performance needs. This need spawned an industry and today Doug is known for the best performance Porsche muffler systems money can buy. This particular Bursch street muffler is quiet, high performance and single tailpiped to neatly exit through the stock valance. The best alternative to the factory systems.

Bursch Muffler Exhaust, 914 1970-72 1.7 & 1.8 ... [RBX1403 \\$275.00](#)

Bursch Muffler Exhaust, 914 1973-74 1.7 & 1.8 ... [RBX1413 \\$275.00](#)

Bursch Muffler Exhaust, 914 1973-74 2.0 ... [RBX1423 \\$275.00](#)

Bursch Muffler Exhaust, 914 1975-76 ... [RBX1433 \\$285.00](#)



Dr. 914's Beautiful 914-6 A-471 GT
See the Steel Flares on Page 90

Parts that are replacement, used or reproduction are not approved, guaranteed, or warranted by Porsche; use of unapproved parts may negate the factory warranty, or alter safety, emission, aerodynamics, or fuel consumption characteristics.

ENGINE 914



MONZA STYLE MANTA EXHAUST SYSTEM

The Monza exhaust has been a proven winner with us for the past twenty years! Relatively quiet, this muffler will increase your 914's top end performance, give you the sporty look of four chrome pipes, and fit under the stock short valance! Manta also backs their systems with a three year guarantee! 1975-76 dual tip will fit a catalytic converter.

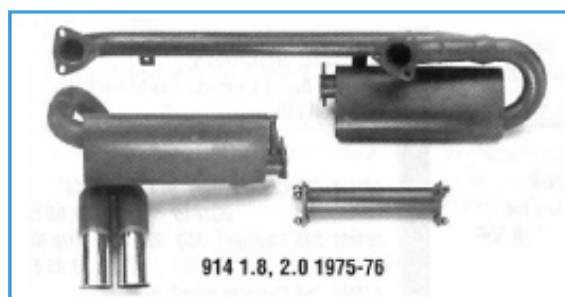
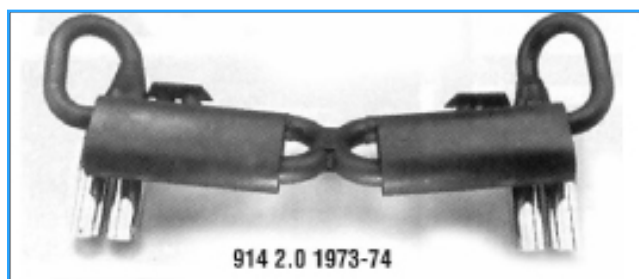

All 1975-76 ... [R88 1262 \\$273.90](#)
 All 1.7, 1.8 ... [R88 1265 \\$273.90](#)
 1973-74 2.0 ... [R88 1266 \\$295.90](#)
 1.7 Muffler Gasket ... [R025 251 261 \\$5.49](#)

Muffler Nut & Bolt Kit (2 req'd.) ... [B900 075 085 02K \\$3.50](#)
 73-74 2.0 Muffler Gasket ... [R039 251 261 \\$5.20](#)
 1.8, 2.0 75-76 Muffler Gasket ... [R025 251 261 \\$5.49](#)



Factory Tail Pipes

1. 1.7 Short for Valance with Hole ... [R021 151 100 E \\$57.75](#)
2. 1.7 Long for Valance with Notch ... [B021 251 053 C \\$57.75](#)
3. Short, for 1.8 Muffler, and Valance with Notch ... [G000 071 347 \\$23.93](#)
4. Short 1.8 Muffler, and for Valance with Notch ... [G022 251 185 \\$33.72](#)
5. Factory Appearance Chrome Tip for All 1.7 & 1.8 ... [RZPW 151 052 \\$63.96](#)



1970-74 1.7 & 1.8

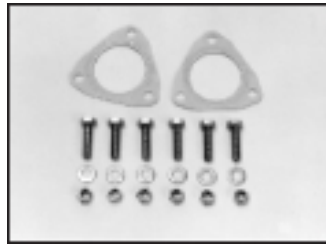

1975-76

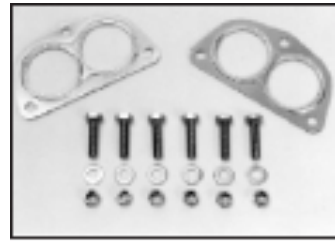

1973-74 2.0

Muffler Nut and Bolt Kit, Muffler Gasket 1.7, 1.8, 2.0

Our beautiful muffler gasket kits offer you everything you need for a perfect installation except a little labor! Don't fight rusted bolts or SAE sized hardware. Use the right stuff.

Muffler Installation Kit (specify) ... [B914 251 000 00 \\$16.50](#)



Muffler 1.7 and 1.8

1970-74 1.7 & 1.8 muffler complete with tailpipe kit and installation kit, for that perfect factory look! And, it's quiet.

Muffler 1.7 and 1.8

... [R021 251 053 C \\$450.00](#)



All 75 & 76 Muffler - Factory Look

From our friends at Dansk, a factory-type muffler for your pristine original.

Pre-Exhaust Silencer ... [G039 251 053 \\$795.00](#)

Cat Test Pipe ... [G039 251 058 \\$69.30](#)

Secondary Silencer ... [R039 251 055A \\$631.00](#)

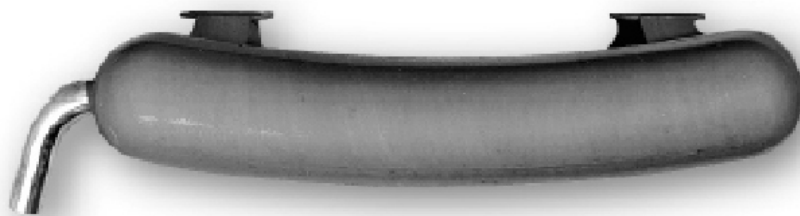

914 2.0 Muffler from Dansk

Dr. 914 recommended for the ultimate in 2.0 performance and concours entry!

2.0 Dansk Muffler ... [RPC G251 051D \\$545.00](#)

Ask about great deals on used stainless steel heat exchangers!



Heat Exchangers

Made by our friends at Dansk, these OEM quality heat exchangers are a great and original fit. Fits 914/4 2.0.

Left ... [G039 256 091 \\$935.86](#)

Right ... [G039 256 092 \\$935.86](#)

ENGINE 914



Heater Control Valve

Left, 914-6, 1970-72; 914 1970-76. Made of steel and painted black.

Heater Control Valve, Left ... [R022 256 205B \\$120.00](#)

Heater Control Valve, Right ... [R022 256 206B \\$120.00](#)



Warm Air Elbows

Why buy the expensive (\$95.00 each) factory warm-air elbow when you can have our improved ones for less than half the price? Made of heavy gauge tube steel, this is the part that fits in between the heat exchanger and the heater control valve on all 70-74 four cylinders. This item will last the life of your 914. SOLD EACH.

Warm Air Elbow ... [B022 256 121 \\$30.80](#)



Heater Blower Hoses

For hot times! Wonder why the heat flow is meager even though the exchangers are in perfect shape? The blower hoses may be bad! We have factory originals for you concours buffs or heavy duty reproductions for rugged use.

1. 1970-76 Long Right Factory Hose

... [G461 261 235A \\$35.00](#)

2. 1970-72 Short Left Factory Hose

... [G411 261 235A \\$15.00](#)

3. 1973-76 Short Left Factory Hose

... [GPCG 261 233 \\$35.00](#)

4. Long Repro Hose

... [B461 261 235A \\$13.20](#)

Short Repro Hose 1973-76

... [BPCG 261 233 \\$8.80](#)

Short Repro Hose 1970-72

... [B411 261 235A \\$8.80](#)

Aircraft Quality Heater Hoses & Fresh Air Hoses

These long-lasting aircraft quality heater hoses conduct only the hottest heat to the front of your 914, while providing flex during engine movement! Fit in between the heater control valve and the body. Order 4 hose clamps as well! Fresh air hoses perfectly replace those in the front trunk ventilation compartment for the perfect concours look. These hoses measure 55" in length.

'70-74 Heater Hose ... [B914 572 154 10 \\$13.75](#)

'75-76 Heater Hose ... [B914 572 154 10 \\$13.75](#)

Heater Hose Clamps ... [R111 501 159 B \\$5.45](#)

Fresh Air Blower Hose ... [R914 572 123 10 \\$18.50](#)

Side Vent Hose ... [R914 572 109 10 \\$18.50](#)

914-4 Headers & Supertrap Muffler

This is a race proven exhaust system suitable for the street. You'll see a 7 - 15% increase in horsepower depending on what other modifications you have made to your engine. I designed this set for my own race car when I was running a production 914-4. We have made minor changes to the basic design to allow it to be used with ported heads for modified engines. While some people believe "bigger is better," we have found that the 1.5" tube gives you the horsepower and torque in the power band of the type 4 engine. These headers fit from 1.7 liter to 2.++ engines. Exhaust system has been designed to use a 2.5" ID X 4" OD SuperTrap muffler which exits through the factory hole in the rear valance.

Headers ... [RKH 35325 \\$548.90](#)

Polished Supertrap Muffler

... [RST 446 2517 \\$250.80](#)

The Perfect High-Performance Combo!

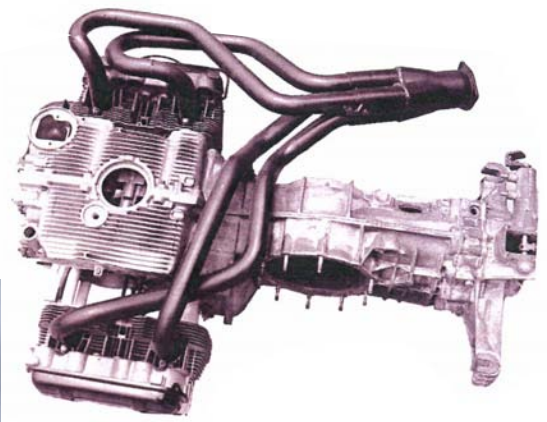

**SUPERB PERFORMANCE!
SUPERB SOUND!**



Heater Blower Update

Our blower update changes your '73-74 heater system to the more powerful '75-76 system, providing increased circulation and defrosting power. Easily installed, you will wonder why the factory did not install this kit!

Heater Blower Update Kit ... [BMIS 400 \\$38.50](#)

Heat Exchanger Kit

Our 43-piece heater package eliminates the plumbing puzzle. Originally conceived to replace the factory defective '75-76 system, you can use this package for heater system replacement on all 914s.

Our Package Includes The Following:

- 2 Heat Exchangers (L & R), 2 Rear Branch to Heat Exchanger Clamps,
- 1 Bursch Muffler System, 2 Warm Air Elbows, 1 Nut & Bolt Kit
- 2 Branch Pieces (L & R) (Used), 1 Heater Cable Set , 4 Copper Exhaust O-rings
- 2 Heater Hoses, 12 Sheet Metal Screws, 2 J-Pipes (Left & Right, Used)
- 2 Muffler Gaskets, 1 Rear Muffler Bracket,
- 2 Heater Control Boxes (Left & Right), 2 Barrel Nuts, 4 Heater Hose Clamps
- 2 Impeller to Branch Clamps (Left & Right, Used)
- 8 Copper Locking Nuts

1.7 or 1.8 Heater Package ... [BSTA 1718 \\$1,850.00](#)

2.0 Heater Package ... [BSTA 20 \\$1,850.00](#)



ENGINE 914

HONDA **SHOP ONLINE** **MERCEDES**
FOR PARTS **BENZ**
FOR OTHER CARS IN
YOUR STABLE **CHEVROLET**

European or Asian, contemporary or classic. Same day shipping, instant inventory checks best prices and

FREE SHIPPING for any order over **\$75.00!** Try it now! Just go to

automobileatlanta.com. **TOYOTA**

autoatlanta.com
is still your Porsche exclusive site

THE 916

Mankind's Ultimate 914!



Parts that are replacement, used or reproduction are not approved, guaranteed, or warranted by Porsche; use of unapproved parts may negate the factory warranty, or alter safety, emission, aerodynamics, or fuel consumption characteristics.

770-427-2844 or 800-792-4944



Branch Piece to Impeller Clamp

Left or right.

Left ... [G021 256 322B \\$14.45](#)

Right ... [G021 256 321D \\$14.45](#)



Branch Clamp Gasket

Wonder why the branch piece clamps fit so loosely? The gaskets are missing!! Install these pre-molded factory items and increase the heat flow!

Left ... [G021 256 325 A \\$27.74](#)

Right ... [G021 256 326 A \\$30.61](#)



Rear Branch Piece Clamp

Our own great repro!

Rear Branch Piece Clamp

... [B021 256 511A \\$14.45](#)

HEAT EXCHANGER/MUFFLER HARDWARE KIT

This kit consists of all the proper hardware to install heat exchangers and a muffler, including the rare copper locking nuts to ensure a perfect installation. Remember to install the exchangers one at a time and torque in an X pattern to 18 ft lbs. (This kit is included in the heat exchanger kit).

Hardware Kit ... [BAAA 256 000 \\$27.50](#)

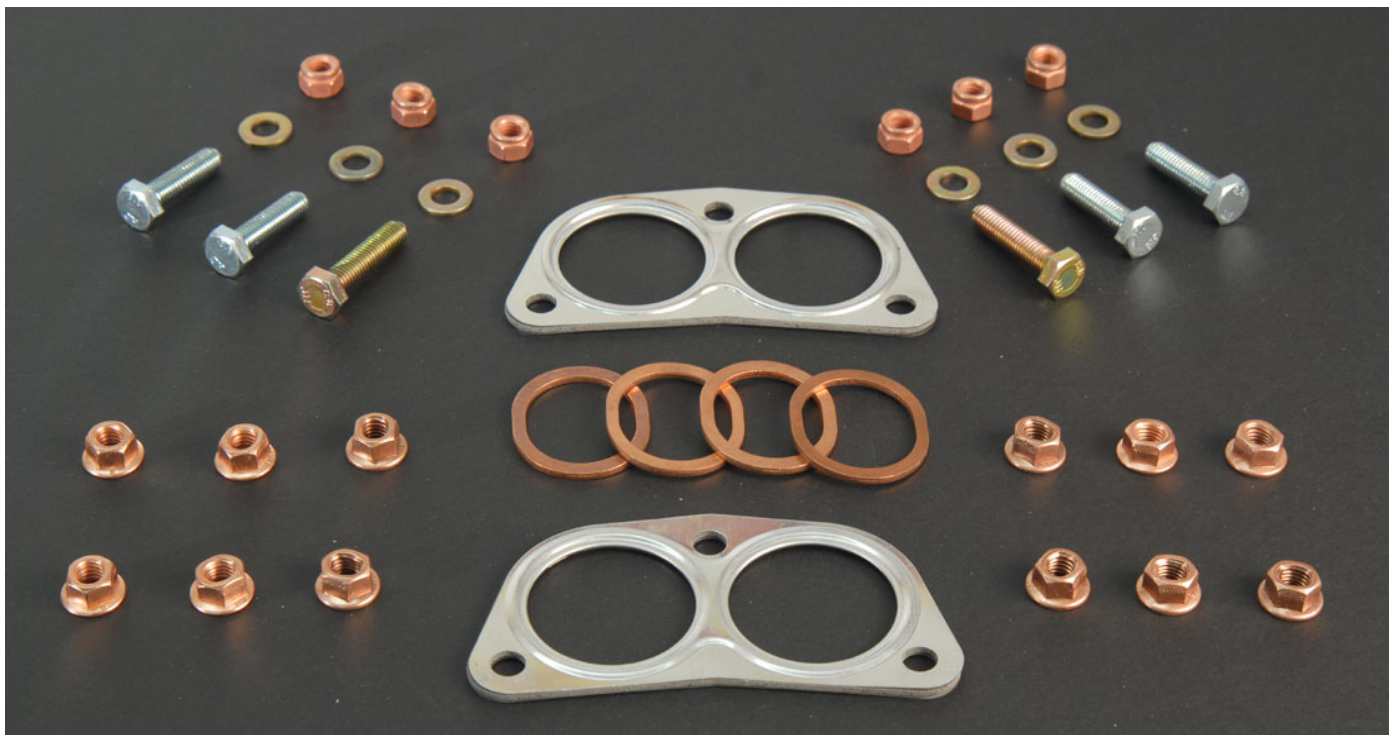

FUEL/EXHAUST

RECONDITIONED FUEL TANK



Reconditioned to our
exacting standards.
Excellent replacement!

Reconditioned Fuel Tank... [BTC1030 \\$350.00](#)
Core charge \$300.00



Filler Neck To Expansion Tank Seal

Wonder why the gas smell in the cockpit? This could be the culprit! Seals the filler neck to the gas tank, it is now dry after thirty some years and needs replacement. Make sure you check the lower fuel tank lines as well. The tank is easily removed after running low of gasoline.

Filler Neck to Expansion Tank Seal
... [G914 201 893 10 \\$10.82](#)



Por 15 Marine Clean

No other cleaner works as fast or as well! Removes grease, oil, mildew, algae, soap film, and wax. Will not leave residues, noxious fumes, or flammable solvents. Can be diluted with water. Safe to use on canvas, vinyl, nylon, and metals. Marine Clean is a great first step in any restoration project. See for yourself.

Por 15 Marine Clean, Gallon ... [RGR6018 \\$23.65](#)



Gas Caps

These are the final solution for solving fuel delivery problems. Bet you didn't even know there was a strainer sock on the end of the gas tank fitting! Piece number one: 1970-early 74 Clip on Gas Cap, DISCONTINUED BY PORSCHE, LIMITED AVAILABILITY HERE AT 914 WORLD HEADQUARTERS!

Gas Cap, 1970-74 ... [B343 201 551 \\$19.50](#)

Gas Cap, 1974.5-76 ... [G914 201 207 10 \\$24.50](#)

Gas Cap Seal ... [G914 201 227 10 \\$4.64](#)

Fuel Sender Gasket ... [R477 919 133 \\$7.10](#)



Nipples, Nuts and Washers

Nipple, Fuel Tank ... [G914 201 043 10 \\$47.9](#)

Aluminum Nut for Nipple ... [G311 201 231A \\$15.16](#)

Washer, Large ... [R311 201 235A \\$1.00](#)

Washer, Small ... [R914 201 147 10 \\$1.00](#)



Gas Tank Fuel Strainer Screen

No one ever changes this one! Installed over the delivery nipple on the bottom inside of the gas tank, this screen filters out all of the particles before they hit the fuel filter and ruin the injection system or at least shut down your car. We have seen many brand new fuel pumps fail when newly installed without strainer replacement. Easily installed after removing the gas tank, great time to order the lower fuel line kit and some gas stabilizer.

Gas Tank Fuel Strainer ... [R113 209 147 \\$7.42](#)

Rebuilt Fuel Pump

New fuel pumps have become way too expensive and used ones are failing these days, so we have contracted with an excellent rebuilder to restore the old ones, core charge \$100.00 Make sure, however, that you clean the gas tank, replace the strainer sock, and replace the fuel filter.

New Fuel Pump, 1970-1974 ... [R311 906 091D \\$428.20](#)

Rebuilt Fuel Pump, 1970-1974 ... [B311 906 091D \\$185.00](#)

Rebuilt Fuel Pump, 1975-1976 ... [B043 906 091 \\$159.50](#)

Rebuilt Fuel Pump, 914-6 ... [B911 608 107 00 \\$192.50](#)

1970-74



1975-76



Facet Fuel Pump For Carbs

The least expensive and most reliable way to assure proper pressure gas flow to your carb set-up. We have used facets for years with 100% reliability

Facet Pump ... RUN730 4815 \$51.40



Fuel Filters

Too many have neglected this important part and now wonder why their car dies after warmup ... the fuel filter is clogged (you may want to change the strainer sock as well). Small to small 1970-74 filter and large to small 1975-76 filter. Original equipment supplier parts assure perfect fit and function.

1. 1970-74 Rear Mounted Filter

... [R311 133 511 D \\$17.71](#)

2. 1975-76 Front Mounted Filter

... [R133 133 511 \\$13.00](#)



Lower Fuel Tank Line Kit

Gas smell in your 914? Its probably caused by those hidden away fuel lines under the tank! Renew them after all of these years with our pre-cut German hose, special non-intrusive fuel line clamps, and a new fuel filter. Kit includes a length diagram for easy installation.

Lower Fuel Line Kit with Diagram, 1970-74 Style ... [BAAA 201 000 74 \\$29.50](#)

Lower Fuel Line Kit with Diagram, 1975-76 Style ... [BAAA 201 000 76 \\$29.50](#)



FUEL PUMP RELOCATION KIT

Developed at Automobile Atlanta, and featured in VW Porsche Magazine, this fuel pump relocation kit solves vapor lock! Factory authorized and tested in hundreds of 914s, this kit moves the fuel pump close to the 1975-76 location. Everything you need plus precise installation instructions are included.

Fuel Pump Relocation Kit ... [BAA007 \\$55.00](#)

SOLVES VAPOR LOCK!

914 Fuel Pump Boot

These days, if we can find a factory fuel injection harness in any condition it is a miracle. The only alternative is to repair your current one. Injector leads and boots make it as easy as soldering and heat shrinking. Available for both D Jetronic (MPC) and L Jetronic (AFC), these boots and leads make an undetectable repair.

Fuel Pump Boot... [G311 906 101 \\$18.15](#)



Fuel Line Grommets - Through the Tunnel

Who has these? We do! Finally. Four required.

9mm Fuel Line Grommet ... [G914 356 201 00 \\$8.50/each](#)

7mm Fuel Line Grommet ... [G914 356 202 00 \\$8.50/each](#)

Fuel Line Grommet

This is the oval grommet with the nipple head for all 914 applications. Two are required for the engine shelf and two are required for the master cylinder to reservoir lines where they pass through the floor pan hump. Four required for the four cylinder models and three for the six cylinder models.

Fuel Line Grommet ... [G111 957 861 \\$6.50](#)



914-6 Engine Shelf Plug

Plugs the engine shelf drain hole on all 914-6 engine bays. Two required.

Engine Shelf Plug ... [G914 559 243 10 \\$9.50](#)

Fuel Pump Mounts

We have seen many a fuel pump hanging because of old, cracked mounts. Both annoying and dangerous, these mounts are often overlooked on 1970-74 models, as the pump is hidden away over the right heater control valve. These are also critical items when relocating the fuel pump to the front.

Fuel Pump Mount ... [B901 501 864 00 \\$8.50](#)

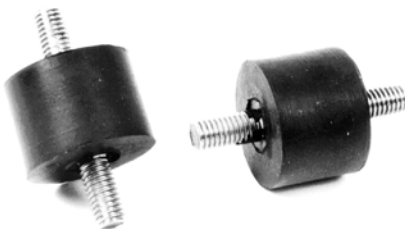

Rainshield Air Cleaner Kit For Your 914-6!

Beautiful set of air cleaner assemblies for your 914-6. Allows increased air flow for more power and a big, clean look. Comes with all hardware for an easy and perfect installation. Set of two.

Rainshield Air Cleaner Set ... [B911 108 001 02 \\$185.00](#)

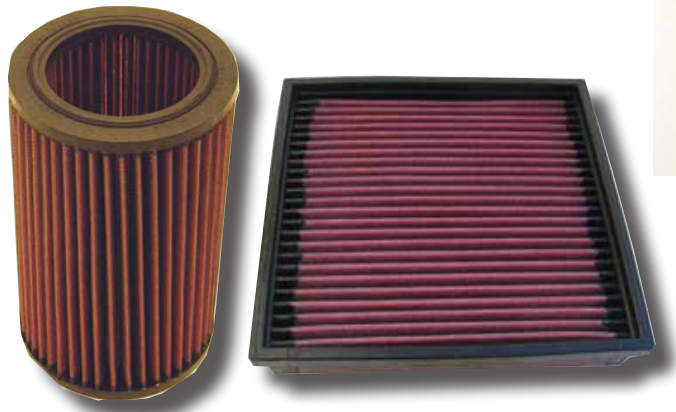

K&N Air Filter

Increase air flow 30% and never replace the air filter again! Permanent washable K&N filters are just right for the road racer in you! Install one and notice the difference immediately.

K&N Air Filter 914-6 ... [RE 2380 \\$52.95](#)

K&N Air Filter 914-4 1974-76 (excl. 1973 1.7) ... [R33 2003 \\$47.95](#)



K&N Air Filter Recharger Kit

12 oz. cleaner and 6.5 oz. filter oil. Completely restore your K&N filter's air flow efficiency so that it will perform like new!

K&N Air Filter Recharger Kit

... [R995 050 \\$13.16](#)



914-6 Carburetor Set

The new, beautiful PMO carburetor is now available! To quote Richard Parr, "We've included many design improvements in our three-barrel carburetor. For instance, we have a single throttle shaft with a ball bearing on each end. The float bowls have near-center fuel pickups with slosh baffling. The floats hang from the top cover, and the needle valves have hooks to enable the floats to pull the needles down as they drop. Each float bowl has a sight glass for checking fuel level. The idle air jets are replaceable for more accurate fine tuning of the idle circuit. The auxiliary venturies have round bases which offer greatly increased stability. The auxiliary venturies come in two aperture sizes: 4.5 and 5.0. The main jets, emulsion tubes and air jets are stacked in a single unit, as in the 48 IDA two barrel. The mixture screw seats extend out into the air stream for better fuel atomization. Our new system of aiming the accelerator nozzles at the curved surface of the auxiliary venturies also improves fuel atomization along with throttle response. The carburetors come in 40mm, 46mm, and 50mm sizes."

Complete Kit includes:

- 2 Carburetors
- Pair of Manifolds
- Watershield air cleaners
- Pressure control unit
- Fuel line, clamps, and filters
- Insulator kit
- Crossbar linkage set
- Oil tank breather

Pair of Carbs Only ... [BPMO 1000 \\$2,585.00](#)

Complete Kit ... [BPMO 2000 \\$3,135.00](#)

Linkage Kit Only ... [BPMOLINK \\$200.00](#)



Parts that are replacement, used or reproduction are not approved, guaranteed, or warranted by Porsche; use of unapproved parts may negate the factory warranty, or alter safety, emission, aerodynamics, or fuel consumption characteristics.

HI-PERFORMANCE PMO INTAKE MANIFOLD SET

Perfect for your 914-6 conversion! Taller stance means higher velocity and more power! Fits perfectly under the engine grille.

Specify engine size when ordering.

PMO Manifold Set ... [BPMOMNFLD \\$400.00](#)



Deluxe Carb Linkage Kit

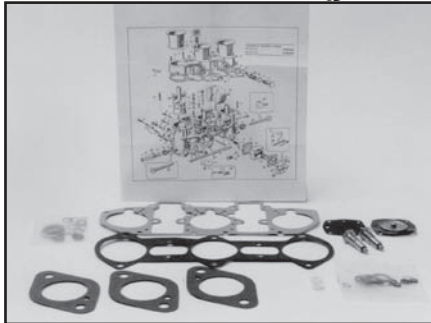

914-6 Weber Carburetor Rebuild Repair Kit

40 IDTP, 2 Required. Weber carburetor rebuild kits directly from Weber are the best when rebuilding the 914-6 carb assemblies. Precise fit and complete with instructions.

Weber Carburetor Rebuild Repair Kit

... [R901 108 948 01 \\$57.75](#)



Weber Carburetor Float Level

If your 914-6 loses power at high speeds or low speed rich running and you haven't checked the float lever, you've missed an important diagnosis. Float level is critical for proper carb tuning. This custom designed tool easily accesses the float bowl and is calibrated for precise measure.

Carb Float Level Gauge ... [GP226A \\$73.20](#)

Weber Carb Book

Everything you ever wanted to know about Weber carbs and a lot you didn't want to know! We receive hundreds of calls each year about tuning and overhaul of Weber carbs, and although we do not prefer them on 914 fours, this book certainly makes tuning and maintenance look easy! A must for the 914-6 owner!

Weber Carb Book ... [RBK 10240 \\$24.15](#)

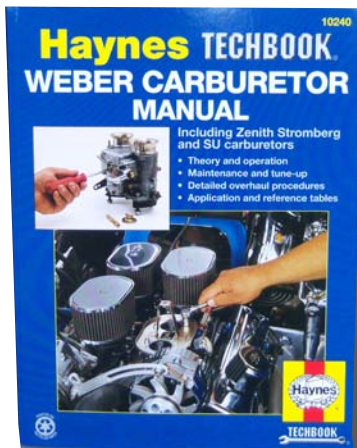



Stainless Steel Fuel Line Kit

Designed to replace the original plastic fuel lines, our kit consists of four lines, the two through the right engine shelf and the two through the tunnel. Designed by our fellow 914 enthusiast Chris Foley, they are a perfect fit replacement to the discontinued factory varieties.

Stainless Steel Fuel Line Set ... [R914 6441 \\$200.00](#)



Call today! We will buy YOUR car! 770-427-2844 Ext. 16!

Synchrometer

The ultimate carb tool to perfectly adjust air flow and balance linkage. No more "by ear" adjustments. With the synchrometer, you can quickly and easily adjust your carbs to a perfect tune.

Synchrometer ... [RTL 1009 \\$39.50](#)



TRANSMISSION



BEEFY INTERMEDIATE PLATE

Necessary when increasing engine size beyond 225 horsepower. This was the weak link to the 901 style gearbox - no more! This custom machined part is 100% stronger than the original it replaces, and allows you to continue to use your old 901 with the highest horsepower engines!

Beefy Intermediate Plate ... [B901 301 035 13 \\$475.00](#)

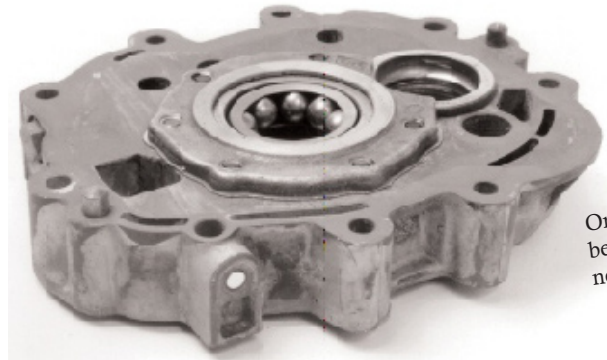

Order new bearings on the next page!

Early Intermediate Plate For 914-6 Conversion

This used part is most necessary when using a late model gearbox in your six cylinder conversion. With this early, used plate you can easily screw in the bell crank stand and install the bell crank.

Used Intermediate Plate ... [U901 301 035 13 \\$200.00](#)

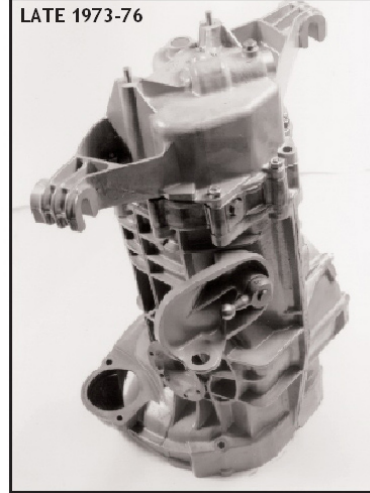
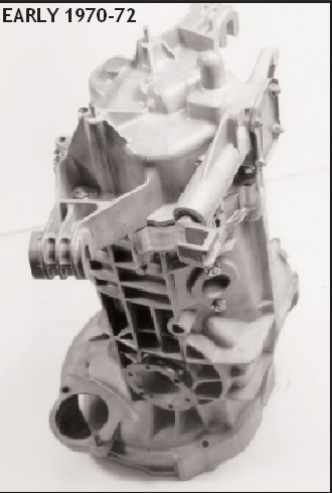

Used & Rebuilt Transmission

Our rebuilt transaxles are completely dismantled and cleaned. The synchros, seals gaskets and all questionable or worn parts are replaced. These transaxles are covered with our six month/six thousand mile warranty against internal breakage and are sold on an exchange basis only.

\$1,000.00 core (depending on the condition. Please do not expect the complete core charge to be refunded as 914 gear boxes these days need many more parts than the rebuild charge covers.

1. 1970-72 914-6 ... [B914 300 012 03 \\$2,000.00](#)
2. 1970-72 914-4 ... [B914 300 012 13 \\$2,000.00](#)
3. 1973-76 914-4 ... [B914 300 012 15 \\$2,000.00](#)

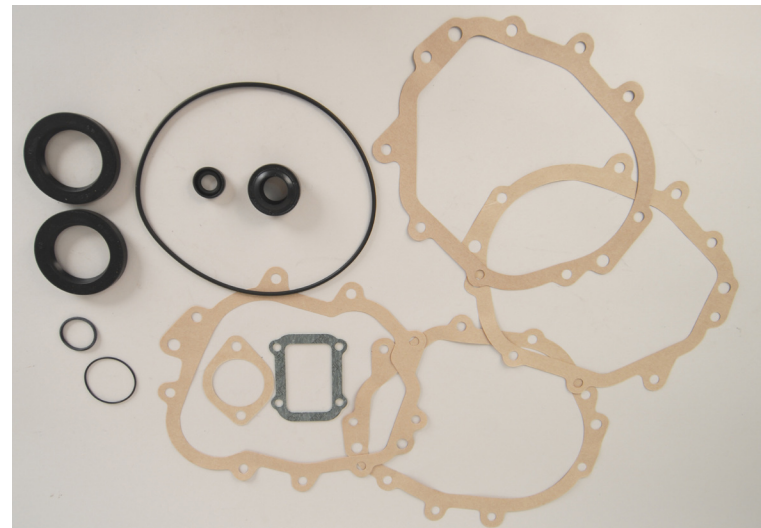

Transmission Gasket Kit

From the original equipment manufacturer, everything you need to completely reseal any 1970-76 914 transmission.

Transmission Gasket Set ... [R914 300 901 00 \\$57.75](#)



First Gear Repair Set

Your 914 grinds going into first gear? Won't go in? Pops out of gear? You need our first gear repair kit. Our ever popular kit lets you repair first gear with the transmission in the car! Comes complete with instructions.

1st Gear Repair Set ... [BAAA 300 000 000 \\$525.00](#)

1st Gear Repair Instructions Only ... [BTC 1045 \\$10.00](#)



Intermediate Plate Bearings

Pinion Shaft Bearing ... [R999 052 016 00 \\$150.15](#)

Main Shaft Bearing ... [R999 053 025 00 \\$259.88](#)

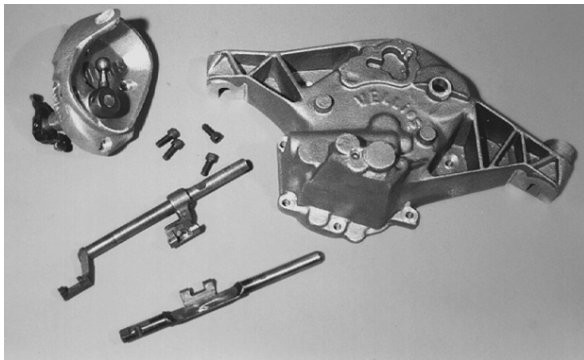

916 Rear Shift Kit

Expensive, but worth it when installing the higher horsepower six cylinder engines in a 914. Kit is complete to convert and hang the revered 915 gearbox in the 914.

916 Rear Shift Kit ... [BMIS 500 \\$2,524.50](#)

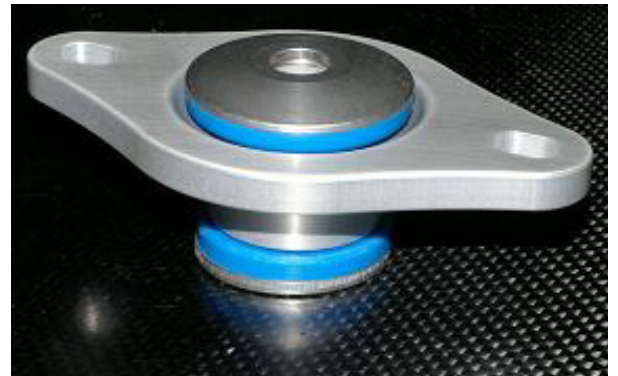

Semi-Solid Transmission Mount

This mount is designed specifically for the transmission mount duty on the 914, the body design is NOT the same as the 911 engine mount - often substituted - the 914 transmission mount is a unique hanging design, our body component is designed to suit. The slotted holes allow for easy "pre-load free" installation, or to accommodate your distorted mounts where 911 engine mounts have previously been bolted up. Aluminum, Urethane and Stainless steel construction. The elastomer pillows and their configuration is shared with the successful SS Engine Mount that has been a big seller with the 911 crowd.

Semi-Solid Transmission Mount ... [B914 375 025 00 \\$97.90](#)

Order Two!

Transmission Mount - An Inexpensive Alternative

Factory mounts have been discontinued, unless you want to spring for the expensive 914-6 variety! We have found these substitutes to work perfectly though! You will not be disappointed.

Transmount ... [B914 375 025 00 \\$44.00](#)

G = Genuine • R = Aftermarket / Replacement •
U = Used • B = Rebuilt or Reproduction



QUAIFE LOCKING DIFFERENTIAL

Ever exit the fastest, tightest, or off-camber turn and lose precious seconds due to wheel spin? You are ready for the Quaife locker! Don't let one slipping tire kill your time - install a Quaife today.

Quaife Locking Differential ... [R40 309 130 \\$1,725.90](#)



Transmission Roll Pin and Plastic Spacer for Late Model

Wonder why your 1973-76 shift linkage is still sloppy after replacing all of the bushings and tightening everything? Sometimes the roll pin wears and the shift lever needs shimming. These factory parts do a great job repairing your problem.

1. Roll Pin ... [G900 309 001 00 \\$4.50](#)
2. Shift Lever Shim ... [B914 303 173 \\$5.44](#)
3. Shift Shaft Seal ... [R900 112 \\$6.93](#)



VDO Speedo Angle Drive

If your speedometer completely fails look at the angle drive first before suspecting the cable. Easily checked by disconnecting the speedometer cable then lifting the car and putting it in gear to see if the angle drive spins, the part is easily replaced. Always try to buy a new one as this is a wear part. Purchase a speedo angle drive seal at the same time to stop the transmission fluid leak. It fits on the drive gear in the rear tail cover and is easily removed with the rear 13mm headed set screw. (you will have a fluid spill when this is removed so get ready!) Refill with 80/90 weight oil only.

VDO Speedometer Angle Drive ... [R914 318 029 65.00](#)

Transmission Ground Strap

Essential Part! Wonder why your 914 is cranking slowly or your accelerator cable is wearing out prematurely or smoking? The rear transmission ground strap is bad! Replace it with one of our beautiful new ones and get the cranking power back to your car! Make sure you preclean the contact surfaces first!

Transmission Ground Strap

... [.....](#)



Synchros, Sliders and Dogteeth - Do It Yourself

1. 1st Speed Dogteeth ... [R911 302 903 00 \\$127.05](#)
- 2nd - 5th Gear Dogteeth ... [R901 302 224 106 \\$127.05](#)
2. First - Reverse Slider ... [R911 302 226 00 \\$415.00](#)
- 2a. 2nd - 3rd/4th - 5th Slider ... [R911 302 411 10 \\$170.85](#)
3. Synchronizing Ring, 1st-5th ... [R911 302 301 06 \\$82.50](#)



Bushings

Wonder why there is slop in the shifter and the gear range keeps changing? The ball cup bushing is probably broken. This bushing snaps onto the bottom of the shift lever on all 65-86 911 and 912 models as well as 1970-72 914 models and the rear shift lever exiting the transmission on all 1973-76 914 models. Use a little grease and make sure you remove the pieces of the old one.

1. Cup Bushing ... [R911 424 139 00 \\$10.40](#)
2. Crown Bushing ... [R914 424 224 02 \\$11.55](#)



914 world headquarters
PARTS • ACCESSORIES • RESTORATION

AUTOMOBILE ATLANTA
505 South Marietta Parkway/Marietta, GA 30060/404.427-2844

George Hussey, president of Automobile Atlanta is technical chairman of the 914 Owners Association and advisor for "914 Restorer's Guide to Authenticity." He is always available for how-to advice.
Call 404-427-2844

505 S. MARIETTA PKWY, DEPT. VWP, MARIETTA, GA 30060

AUTOMOBILE ATLANTA

READ ALL ABOUT IT!

Here's your chance to get close to one of the world's great cars, the mid-engine 914. And to get acquainted with the company dedicated to preserving this sports car legacy.

In its latest sourcebook, Automobile Atlanta provides you with a 914 overview: 80 pages of the world's largest parts inventory, a wealth of restoration and technical know-how. And as an added feature, a sports clothing and gift selection.

Turn on with the 914 catalog: \$5.00

Vintage Automobile Atlanta Ad from the '80s.

FLASH!
We buy and sell 914s!
Call us today to discuss!
(770) 427-2844 Ext. 16

FRONT AXLE/STEERING

Weltmeister Front Swaybars



Weltmeister swaybars are exclusively designed for your Porsche® so you can depend on a precise fit and infinite adjustability. 19mm for street driving, 22mm for street, autocross or track use.

Front 19 mm ... [RSB 1000 \\$359.98](#)
Front 22 mm ... [RSB 1100 \\$407.55](#)



Swaybar Adapter Kit

1. Front Arm to Stabilizer Clamp ... [RSB 1900 \\$27.44](#)
2. Through the Body Reinforcement Weld In ... [RSB 1955 \\$25.95](#)

Hollow, Plated and Plugged Torsion Bars

Plated & Plugged Hollow torsion bars are the best available. The ends are plugged to prevent moisture entry that rots ordinary hollow bars from the inside out. The entire bar is zinc plated. Excellent quality control means proper spline fit and spring-rate consistency bar-to-bar. Inferior quality competing bars fail on all counts. Hollow bars provide a nice weight savings over equivalent spring rate solid bars, especially true of the heavier rear bars. The size given is a solid-bar-equivalent. Actual hollow bar measures about .5mm larger. For 914/6 series front we have 21mm to 23mm. Torsion bars do not fit 914/4 suspensions, they have a different spline count.

914-6 21MM ... [RTT2210 \\$379.44/set](#)
914-6 22MM ... [RTT2220 \\$384.94/set](#)
914-6 23MM ... [RTT2230 \\$316.47/set](#)

Rack and Pinion Cover Seal

Two required.

... [B901 341 165 00 \\$35.00](#)



Torsion Bar Grease Seals

... [G901 341 475 00 \\$4.63](#)

Front Swaybar Mounting Plate

Beautiful cad-plating. Factory part, easily welded in! Order two.

... [G914 501 162 10 \\$25.66](#)



Swaybar Drop Link Bushing with Sleeve Set

Set of 4 Factory Sway Bar Drop Link Bushings w/ sleeves, 1 set needed. Improve suspension performance! Worn and soft original suspension bushings flex and compress, allowing suspension components to "float", changing your alignment specs and making your Porsche's handling less than what it should be. Weltmeister poly-graphite bushings are the best. They have a bearing-like action, yet do not squeak like delrin or teflon. As a result, you will not get strange looks at stop lights from the girl in the BMW as she laughs at the squeaky Porsche! Weltmeister Bushings are proven winners in IMSA, SCCA, Porsche Club Racing, and an inexpensive update that you will really love!

Swaybar Drop Link Bushing With Sleeve Set ... [RPB1013 \\$26.40](#)



BILSTEIN SHOCKS

Bilstein shocks are the ultimate for your 914. Many 914s were optionally equipped with them, and the handling difference is amazing! Bilsteins are gas shocks with very precise valving for ultimate control. They will last the life of your 914, are unaffected by temperature change.

Set of Two Front Bilstein Shock Absorbers
... [RBL 112 \\$319.00](#)



KYB Shocks

KYB gas shocks, we have found, are the best buy for the money. If you want a firm, controlled ride—unaffected by temperature change—KYB's are for you!

Set of Two Front KYB Shock Absorbers
... [R361004 \\$167.93](#)

Koni Shocks

Koni shocks are the race proven standard. They have been making high performance shocks for Porsches for years. Konis provide a firm, controlled ride and flatter cornering and are also externally adjustable. Front and rear pictured!

Set of Two Front Koni Shock Absorbers
... [RKO 1077 \\$457.96](#)



Boge Shock Absorbers

Original equipment replacements but updated to the latest performance expectations. Easy replacement in about 30 minutes without even removing the tires (see the complete procedure in the "Tech Tips 700.") Price is for a set of two. Replace the rear shocks and springs while you are at it and then have a four wheel alignment done. You will not believe the difference!

Boge Shock Absorbers ... [R914 341 903 00 \\$180.00](#)

914 Wheel Bearings

914-4 Front, Inner ... [R311 405 625B \\$10.40](#)

914-4 Front, Outer ... [R311 405 645 \\$9.62](#)

914-4 Wheel Seal ... [R321 501 641 \\$6.93](#)

914-6 Front, Inner ... [R211 405 645 \\$10.99](#)

914-6 Front, Outer ... [R211 405 645 D \\$10.99](#)

914-6 Wheel Seal ... [R477 405 641 \\$5.95](#)



Factory Swaybar Bushings & Links

1. Front Swaybar Link
... [G914 343 075 00 \\$81.16](#)
2. Front Swaybar Link Bushing (4 Req'd)
... [G901 343 783 00 \\$21.45](#)
3. Front Swaybar to Body Bushing (2 Req'd)
... [G901 343 792 02 \\$19.68](#)
4. Front Swaybar Mounting Plate
... [G914 501 162 10 \\$25.66](#)



FRONT AXLE/STEERING



Cad-Plated Strut Clamps

Cad plated parts for concours better than the lightly plated factory issue, heavy duty cad plated parts impress the concours judges. These are the ones that show under the hood. Sold on an exchange basis. \$5.00 Core charge.

Single Hole Strut Clamp ... [B911 501 934 00 \\$11.00](#)

Double Hole Strut Clamp ... [B914 501 900 10 \\$11.00](#)



Weltmeister Camberplate Kit

Get a dramatic increase in steering and suspension feedback, quicker turning and precise cornering. Weltmeister's new CamberPlates replace soft top strut rubber bushings with precision spherical bearings. More-over, the lightweight aluminum CamberPlates are machined with two sets of mounting holes, providing you with a wide range of camber possibilities. You can get up to 1 to 11½ degrees more negative camber, so you can take full advantage of the latest super-sticky race and street tires. Bolt-in installation requires no body modifications. Fits all Bilstein and Koni shocks. Installation requires front suspension realignment. The cross-brace kit is easy to bolt in and can be added later in 30 minutes or less. This combination provides ultimate strut tower strength for improved turn in and maximum tire grip.

Weltmeister Camber Plate ... [RMB 343 01 \\$399.95](#)

Ball Joint Pin & Bolt

Ball Joint Pin ... [R911 341 119 06 \\$16.50](#)

Ball Joint Bolt ... [R900 075 111 08 \\$3.46](#)

Locking Plate ... [G901 341 42 600 \\$11.68](#)



Upper Strut Bushings

Set of two.

... [B901 341 018 90 \\$99.50](#)



Bump Steer Kit

Does your steering wheel shake every time you hit a bump? Your 914 is too low and the steering geometry is off. Correct the problem by raising your car or installing the bump steer kit.

1. 1970-72 Kit ... [RBSK 100 \\$14.24](#)

2. 1973-76 Kit ... [RBSK 200 \\$17.10](#)



Turbo Tie-Rod Kit

The turbo tie rod kit was installed only on the 930 turbo as an improvement to the steering. Since 930 and 914 front suspension is virtually identical, this kit fits the 914 perfectly and makes steering PRECISE. This kit is a must for ultimate handling, is easily installed, and eliminates the old worn out tie rod assemblies, replacing everything from the steering rack out with efficient modern parts.

Turbo Tie Rod Kit ... [RMIS 800 \\$155.00](#)

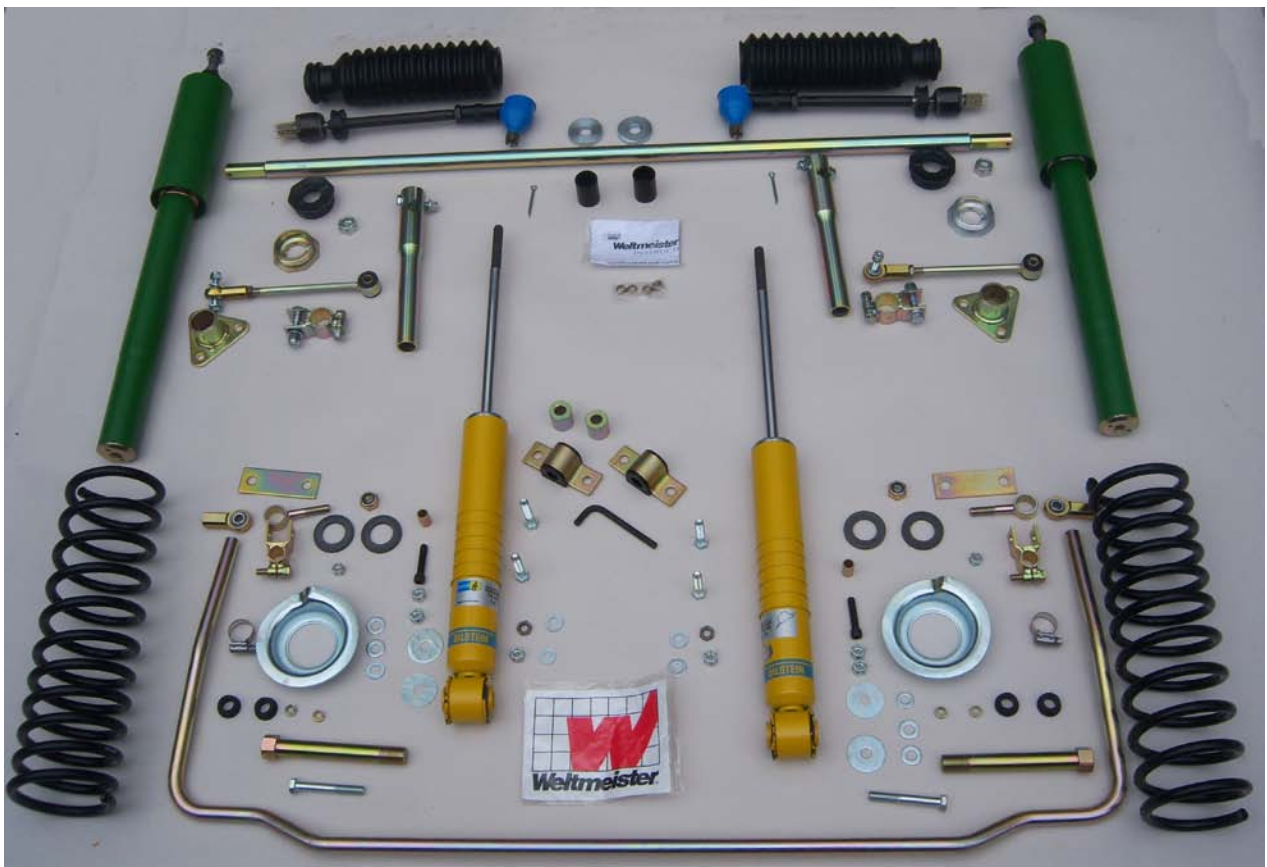

Install Our Performance Quality 914 Suspension Kits For Dramatic Control

Our suspension kits will make your 914 handle better than ANY production 914 ever did! We install these kits in our shop, and the improvement is dramatic! The Deluxe Kit Contains: 1— 22mm adjustable front Weltmeister sway bar; 1 Turbo tie rod kit; 4 Bilstein gas shocks (Front and Rear); 1 16mm rear Weltmeister sway bar; 1 Pair 100 LB Springs

Deluxe Susp. Kit ... [BDK 914 00 \\$1,550.00](#)



Autocross/Road Course Econo-Deal

Consists of 4 KYB shocks, 140lb. springs, 1 front 23mm swaybar. This is the ideal set up for autocross.

Econo Susp. Kit ... [BEK 914 \\$660.00](#)

**These Kits Really
Make Your 914
Handle!**

FRONT AXLE/STEERING

MOMO STEERING WHEELS

Momo wheels are of the best, highest quality of all after-market wheels. We have chosen some of our favorite models. All wheels come with an appropriate hub and Momo horn button. If you don't see the model you're looking for, just call or email us.



a



Momo
Tuner...
RMB34723
\$295.90



b

- A. Momo Prototipo Black/Black ... [RMB35269 \\$251.90](#)
- B Momo Champion ... [BMOMOCHA35BK1B \\$205.00](#)
- C. Momo Fighter ... [BMOMOFGT35BK1B \\$266.00](#)
- D. Momo Pilota ... [BMOMOPIL35BK1B \\$255.00](#)
- E. Momo Prototipo Black/Silver ... [RMB35269 \\$251.90](#)

- Apache ... [RMB 34716 \\$273.90](#)
- Champion ... [RMB 34717 \\$255.00](#)
- Club4 ... [RMB 34718 \\$394.90](#)
- Competition ... [RMB 34719 \\$242.00](#)
- Fighter ... [RMB 34720 \\$288.20](#)
- Millenium ... [RMB 34721 \\$339.90](#)

- Momocorse ... [RMB 34722 \\$273.90](#)
- Power ... [RMB 34723 \\$295.90](#)
- Momo Hub Kit ... [RMB 34724 \\$66.00](#)



c



d



e

Don't See the Momo Wheel You're Looking For? Just call us and we will get it for you!



Factory-Approved Porsche Horn Button

For Momo wheels.

...RMB 34725 \$87.45



914-6 Decal Set For Steering Column

One of the nicer finishing touches for your "six" restoration, or a great way to learn how to operate the column switches! Original factory equipment but slightly different than the original production set.

Decal Set ... [G901 559 330 01 \\$55.91](#)



Horn Repair Kit

Everything you need for the repair of the expensive horn butterfly.

1. Horn Boot ... [G901 347 823 01 \\$12.71](#)

2. Horn Contact Plate ... [G914 347 099 00 \\$39.54](#)

3. Steering Wheel Bearing ... [R911 347 771 02 \\$29.64](#)

4. 914-6 Horn Stalk ... [G914 347 831 00 \\$22.20](#)

5. 914-4 Horn Stalk ... [G914 347 832 00 \\$23.53](#)

6. Horn Base Plate ... [B914 613 805 A \\$29.50](#)

7. Steering Wheel Bearing Sleeve ... [B111 953 535 D \\$6.50](#)



Recovered Steering Wheel

The most beautiful touch to a perfect interior is an original leather covered steering wheel. New, just over \$1600.00, no longer available from the factory, the leather sewing cannot be distinguished from the factory original. Our recovering expert does a superb job on this must-have wheel. You'll be thrilled! (Center horn pad not included of course!) Core charge \$200.00.

Factory Recovered Steering Wheel ... [B914 347 091 11 \\$195.00](#)

Steering Wheel Recovering Kit

If you cannot afford a recovered wheel, do it yourself with the same kit the professionals use. If you're good, you can experience the same professional results. Restore your leather wheel to brand new with this nice kit.

Recovering Kit, 3-Spoke

... [RWS3 \\$60.44](#)

Leather Cover for Plastic 914 Steering Wheels ... [RWSA \\$49.45](#)



REAR AXLE



Rebuilt CV Axle

Complete CV axle with two joints for all 914 models. Two required per car. Requires a refundable core charge of \$150.00

Rebuilt CV Axle ... [B914 332 009 03 \\$199.00](#)

914-6 Stub Axles

The only practical way to install five lug rear suspension! Stub axles are unique to the 914-6, and fit perfectly into the 911 rear hub as well as attaching to the 914 CV joint.

Stub Axle ... [B914 332 223 00 \\$342.10](#)



Boxed Swing Arm Set

Dramatically increase swing arm rigidity and eliminate twisting with our boxed swing arm reinforcements. Prepared for easy welded installation. Perfect for you V-8 boys!

Boxed Swing Arm Set ... [B914BSA \\$170.00](#)



Alignment Shims & Longer Alignment Bolts

Wonder why your rear wheels are out at the bottom and in at the top? The swing arms have twisted, the springs have sagged and/or the rear end needs alignment! Get the negative camber removed (each mm reduces negative camber by 10 minutes).

Shim 2MM ... [G914 331 533 01 \\$30.25](#)

Shim 3MM ... [G914 331 533 04 \\$34.86](#)

Shim 4MM ... [G914 331 533 05 \\$34.07](#)



CV Joint Grease

All grease is not the same! Ours is molybdenum disulfate and is made in Germany to repack centrifugal velocity joints. Try some, you'll like it. CV joints need to be repacked every 50,000 miles, or more often as they age! (One tube needed per joint.)

CV Joint Grease ... [RLM47 \\$5.50](#)





CV Parts

Missing one or several of these? No wonder your CV joint slings grease, shatters, or comes loose!

1. CV Boot without Flange ... [R901 332 293 10 \\$8.80](#)
2. CV Boot with Flange (the easier way) ... [R914 332 035 00 \\$22.52](#)
3. CV Joint Gasket (4 required) ... [R914 332 237 01 \\$2.20](#)
4. CV Joint Bolt (16 required) ... [R113 501 229 D \\$2.30](#)
5. Cone Washer (16 required) ... [G999 591 849 07 \\$1.00](#)
6. CV Joint Roll Pin (4 required) ... [G999 095 019 00 \\$3.50](#)

Rear Wheel Bearing

If your Porsche has a whine in the rear that varies when turned right or left and continues even when taken out of gear, a rear wheel bearing is going bad. One piece wheel bearing for all of the above captioned models is an easy press in once the cv axle rotor and caliper are removed.



Rear Wheel Bearing
... [R999 053 035 00 \\$49.50](#)

Rear Sway Bar Kit

Automobile Atlanta considers Weltmeister swaybars by far the best buy for the money. Swaybars are the most important component in improving high performance handling. Properly sized, tuned, and balanced swaybars improve control and chassis response while reducing body roll, weight transfer, and speed wander. Weltmeisters are adjustable so you may fine tune them to your chassis set-up and needs. All computer-bent ultra high quality swaybars come complete w/polygraphite bushings (for better load and wear), sliders, adjustable droplinks, hardware and instruction.

Rear Sway Bar Kit ... [RSB3000 \\$339.50](#)



Factory Swaybar Bushings & Swaybar Mounting Plates

1. 1970-74 Rear Swaybar Mount
... [G914 501 259 11 \\$66.04](#)
2. 1975-76 Rear Swaybar Mount
... [G914 501 259 11 \\$66.04](#)
3. Rear Swaybar to Body Bushing (2 required)
... [G914 333 793 01 \\$45.98](#)
4. 1975-76 Rear Swaybar Mount
... [G914 507 027 10 \\$45.84](#)
5. Rear Swaybar Link ... [G914 333 057 00 \\$65.00](#)
6. Rear Swaybar Ball Stud ... [G914 333 565 01 \\$134.22](#)
7. Rear Swaybar Link Bushing (4 required)
... [G901 343 782 00 \\$17.00](#)



REAR AXLE



BILSTEIN SHOCKS

Bilstein shocks are the ultimate for your 914. Many 914s were optionally equipped with them, and the handling difference is amazing! Bilsteins are gas shocks with very precise valving for ultimate control. They will last the life of your 914 and are unaffected by temperature change and have adjustable spring plates.

Rear Bilstein, Set ... [RBL 179 \\$300.00](#)

Koni Shocks

Koni shocks are the race proven standard. They have been making high performance shocks for Porsches for years. Konis provide a firm, controlled ride and flatter cornering and are also externally adjustable.

Rear Koni, Set ... [RKO 1050 \\$404.83](#)



KYB Shocks

KYB gas shocks, we have found, are the best buy for the money. If you want a firm, controlled ride, unaffected by temperature change, KYB's are for you!

Rear KYB, Set ... [RKG9003 \\$160.00](#)

Boge Rear Shock Absorber

Original equipment for us old guys and concours sticklers!

Boge, Set ... [R914 333 051 02 \\$180.00](#)

Make sure you have your original, factory spring plates!

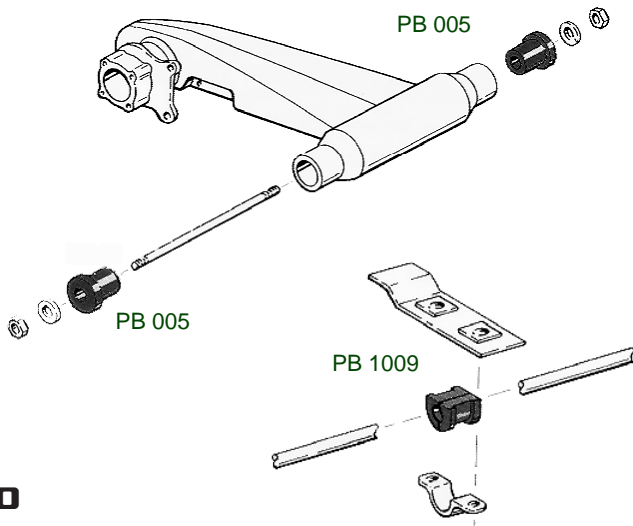

914 Rear Bushings

Improve suspension performance! Worn and soft original suspension bushings flex and compress, allowing suspension components to float, changing your alignment specs and making your Porsche's handling less than what it should be.

Suspension Arm, 4 needed ... [RPB 005 \\$23.65](#)

Set of 4 Suspension Arm Bushings ... [RPB 005P \\$66.00](#)

Sway Bar Bushing, 16mm, 2 needed ... [RPB 1009 \\$14.30](#)

Parts that are replacement, used or reproduction are not approved, guaranteed, or warranted by Porsche; use of unapproved parts may negate the factory warranty, or alter safety, emission, aerodynamics, or fuel consumption characteristics.



Rear Springs

Have you wondered why your car sags in the rear? The factory 914 springs were never strong enough. We offer four weights of springs. The 90 lb set will raise the car to the high factory height. The 100 lb. set will raise the rear to near factory original height and provide a great ride and increased oversteer. The 140 lb. set are for autocrossers or very spirited street driving. 180 lb. bars are for serious road racers or V-8 conversions.

90 lb. Springs ... [RSP 90 \\$115.50](#)

100 lb. Springs ... [RSP 100 \\$120.94](#)

140 lb. Springs ... [RSP 140 \\$126.94](#)

180 lb. Springs ... [RSP 180 \\$121.28](#)

GET RID OF THE SAG!

Factory Swaybar Bushings & Swaybar Mounting Plates

1. 1970-74 Rear Swaybar Mount ... [G914 501 259 11 \\$66.04](#)
2. 1975-76 Rear Swaybar Mount ... [G914 507 027 10 \\$17.36](#)
3. Rear Swaybar Bushing (2 required) ... [G914 333 793 01 \\$45.98](#)
4. '70-74 Rear Swaybar Bracket Reinforcement Plate ... [G914 501 532 71 \\$10.62](#)
5. Rear Swaybar Link ... [G914 333 057 00 \\$53.00](#)
6. Rear Swaybar Ball Stud ... [G914 333 565 01 \\$134.22](#)
7. Rear Swaybar Link Bushing (4 required) ... [G901 343 782 00 \\$9.78](#)



Aluminum Camber Truss

This highly engineered, racing-performance truss will tune your suspension by maintaining your tire's flat contact patch under hard cornering and braking. This is not an easy task without the proper equipment but what an incredible improvement when engineered correctly! Don't be fooled by imitations of lesser design or aftermarketers using tubing of less collapsing pressure strength than chrome moly! We are the original developers and have proven our products performance over 20 years and millions of miles of absolute customer satisfaction throughout the world! The Camber Truss is finished in a durable black

powder coating. There are NO holes to drill, only 4 slits to be made in the carpeting and can typically be installed in 15 to 20 minutes. Designed to maximize your car's suspension control, the Camber Truss will give you an incredible increase in cornering and braking capabilities. Due to our triangulated design, it will maintain your wheels at true vertical, greatly reducing camber change and flattening your tire patches.

914 Aluminum Camber Truss ... [RSE CT 914AL \\$299.00](#)

BRAKES/WHEELS



Cross Drilled Rotors

Increased brake cooling for the racers! Original Zimmerman German rotors, computer drilled for maximum cooling efficiency.

70-mid 72 Front 914-4 ... [B411 407 075 \\$104.50](#)

72-76 Front 914-4 ... [B411 407 075B \\$178.20](#)

Front 914-6 ... [B477405083A \\$89.95](#)

Ferodo Front Brake Pad Set

For 914-4 1970-76. Ferodo brings Formula One technology to your vehicle for better braking, less dust, no squeal and longer brake pad life. For autocrossing and aggressive driving, we recommend Ferodo.

Rear Brake Pad Set ... [RFCP2 \\$59.50](#)



FERODO
THE FIRST NAME IN BRAKES

Front Carbon Kevlar Brake Pad Set

For the ultimate in cool, track stopping power!

Front Carbon Kevlar Brake Pads ... [B914 351 905CK \\$120.45](#)

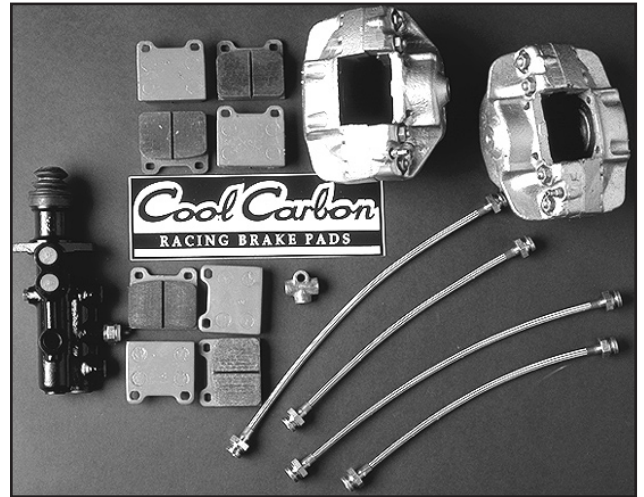
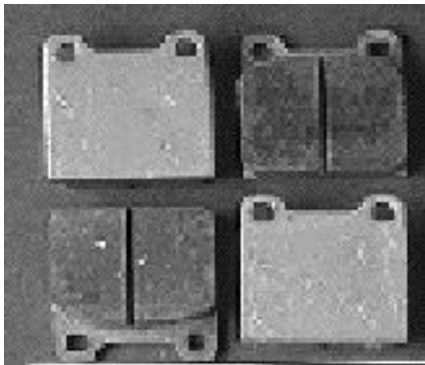

Carbon Fiber Brake Pads Big Calipers, Pads For Big Calipers The Ultimate Braking Kit

Have you ever wondered why the factory did not use the same brakes for the 914 as the 911? The main reason is the 914 is a much lighter car and would have outperformed the 911! Now, 914 World Headquarters brings you our high performance braking kit using 911 calipers and master cylinder, carbon kevlar brake pads, stainless brake lines and a factory "T". This braking set up will astound you with your new found stopping power. Many have commented, "...it is like installing power brakes!" So, if you are sick of your weak 914 brakes and want to out-brake 911 turbos, order the kit today!

Braking Kit ... [B914 BK \\$715.00](#)



Front Brake Caliper Rebuild Kits

Front brake caliper kit for all 914 models - one required per caliper. In addition to this kit you may need front pad clips (411 615 269), front bleeder nipple (901 352 977 10) and front bleeder nipple cap (211 611 483) and a set of brake pads! Bleed thoroughly with our ATE blue brake fluid.

Front Brake Caliper Rebuild Kit, 1970-72

... [R411 698 471 \\$29.64](#)

Front Brake Caliper Rebuild Kit, 1973-76

... [R411698471A \\$21.94](#)

770-427-2844 or 800-792-4944

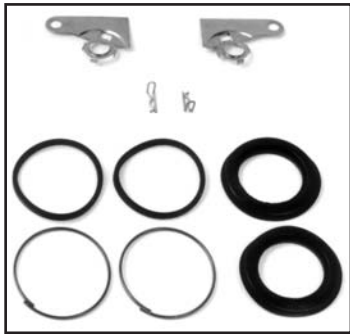

2

Front Caliper Rebuild Parts

All of the following parts are needed for a perfect front caliper rebuild:

1. Front 1970-76 brake caliper repair kit 1970-72

... [R411 698 471 \\$29.65](#)

1973-76 ... [R411 698 471 A \\$21.94](#)

70-72 914-6 ... [R901 351 964 11 \\$20.35](#)

2. Front Pad Clip, 73-76

... [G411 615 269A \\$12.50](#)

Front Pad Clip 914-6

... [G901 351 916 14 \\$12.50](#)

Front Pad Clip, 70-72

... [G901 351 916 16 \\$12.50](#)

3. Front Bleeder Nipple

... [G901 352 977 10 \\$5.45](#)

4. Front Bleeder Nipple Cap ... [R211 611 483 \\$3.29](#)



3



4

Frozen Rotors

Frozen Rotors are simply the best brake rotors money can buy. Serious drivers - those who tend to cross the finish line first - take their edge where they find it. A growing number of them have embraced cryogenically treated brake rotors. Here's why: They resist cracking, warping and fading; Rotors last 2-3 times longer; They stop consistently, lap after lap.

Set of Two, Front 914-4 1970-72 ... [RDC411 407 075 \\$242.00](#)

Set of Two, Front 914-4 73-76 ... [RDC411 407 075 B \\$242.00](#)

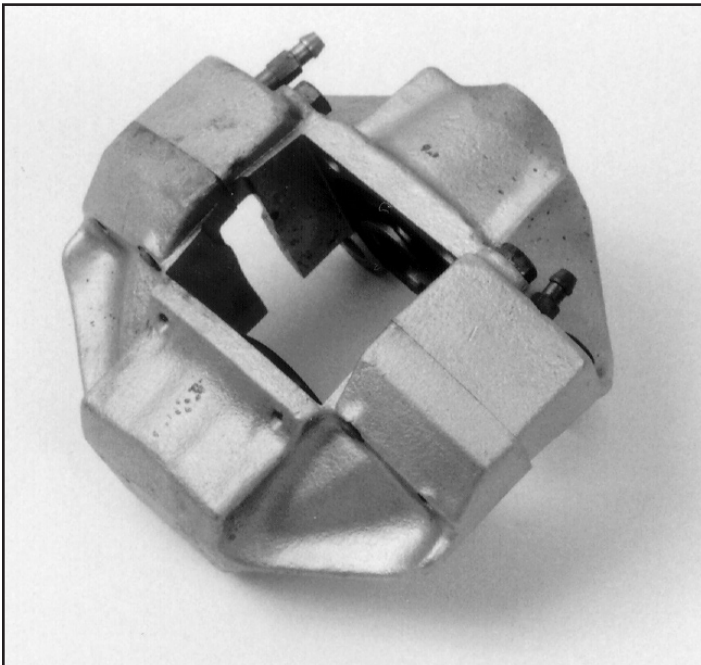

Rebuilt Front Calipers

If you cannot rebuild your own calipers (and we encourage you to do so to save money!), then purchase our excellent in-house rebuilds. Rebuilt with quality factory parts, our calipers are completely dismantled, the exterior is sandblasted, the caliper and bores are meticulously cleaned, and the exterior is repainted. Calipers are guaranteed for six months or six thousand miles for defects in workmanship and sold on an exchange basis only. Please add \$100 core charge when ordering each 914 front caliper.

Front Left 914-4 70-mid 72 ... [B311 615 107B \\$170.50](#)

Front Right 914-4 70-mid 72 ... [B311 615 108B \\$170.50](#)

Front Left 914-4 72-76 ... [B914 351 425 00 \\$181.50](#)

Front Right 914-4 72-76 ... [B914 351 426 00 \\$181.50](#)

Front Left 914-6 ... [B911 351 907 00 \\$170.50](#)

Front Right 914-6 ... [B911 355 246 00 \\$170.50](#)

G = Genuine • R = Aftermarket / Replacement •
U = Used • B = Rebuilt or Reproduction

BRAKES/WHEELS



Rear Slotted Rotors, Set Of Two

Fits 1970-76. (914 352 401 10S & 914 352 401 12S) The latest and the greatest in 914 brake rotors!!! Slotted for the ultimate in cooling original Zimmerman rotors for all 914 four cylinder cars. Slotted rotors let the gasses escape for better stopping power, longer pad life and longer rotor life! Plus they look cool through your wheel. These are a must for all of you racer types who want and edge on the competition.

Rear Slotted Rotors, Set of Two ... [B914 352 401 1012S \\$302.50](#)

Rear Standard Rotors, Each ... [R914 352 401 10 \\$73.18](#)

914-6 Standard Rotors, Each ... [R901 352 401 18 \\$105.00](#)

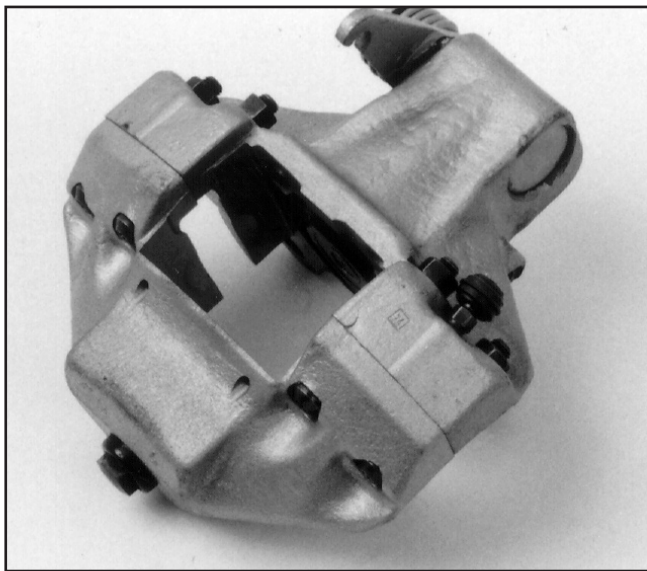

Rebuilt Rear Calipers

If you cannot rebuild your own calipers (and we encourage you to do so to save money!), then purchase our excellent in-house rebuilds. Rebuilt with quality factory parts, our calipers are completely dismantled, the exterior is sandblasted, the caliper and bores are meticulously cleaned, and the exterior is repainted. Calipers are guaranteed for six months or six thousand miles for defects in workmanship and sold on an exchange basis only. Please add \$150 core charge when ordering each 914-4 caliper and a \$500 core charge when ordering each 914-6 rear caliper.

Rear Left 914-4 ... [B914 352 423 00 \\$181.00](#)

Rear Right 914-4 ... [B914 352 424 00 \\$181.00](#)

Rear Left 914-6 ... [B914 352 901 00 \\$302.00](#)

Rear Right 914-6 ... [B914 352 902 00 \\$302.00](#)

REAR CALIPER REBUILD PARTS



2. Outer Adjuster Cap Nut ... [G914 352 919 00 \\$2.35](#)

3. Outer Adjuster Lock Nut ... [R914 352 900 AB \\$2.89](#)

4. Small 8mm Outer Adjuster ... [B914 352 423B \\$25.00](#)

5. Large 10mm Outer Adjuster ... [B914 352 423D \\$25.00](#)

6. Inner Cover O Ring ... [G914 352 900 AC \\$1.21](#)

7. Outer Adjuster C Clip ... [R914 352 900 AD \\$2.31](#)

8. Inner Adjuster ... [B914 352 423A \\$25.00](#)

9. Inner Adjuster Cap ... [B914 352 918 00 \\$4.02](#)

10. Brake Pin Clips ... [G901 351 955 10 \\$1.54](#)

11. Bleeder Nipple ... [G901 352 977 10 \\$8.50](#)

12. Bleeder Nipple Cover ... [G211 611 483 \\$4.99](#)

Rear Brake Pad Clip ... [G311 615 269 \\$16.28](#)



Brake Paste

Perfect for reducing brake squeal!

Brake Paste

... [RGR 2012 \\$7.51](#)

Brake Caliper Paint

Painted calipers are the rage these days, but special paint is needed to ensure that your paint lasts! Our caliper paint does just that. Impervious to brake fluid and brake dust, we use it in our shop all of the time. You will love it. Specify silver, black, yellow, blue, gold, red or orange.

Brake Caliper Paint ... [RCAL850 \\$32.94](#)



Rear Caliper Adjustment Tool

Trying to adjust the inner rear caliper brake pad and cannot reach the adjuster through the swingarm? We have the solution! This super long allen wrench with built in 3/8" drive socket accesses both the cap and adjuster and gives plenty of clearance for your ratchet.

Rear Caliper Adjustment Tool ... [RTL 1407 \\$14.15](#)

Rear Caliper Rebuild Kit

They said that it could not be done! We said do it! We constructed this custom caliper kit from different factory ATE caliper kits and then had five additional seals made and came up with great instructions so anyone (even your girlfriend) can do it themselves! May also need outer adjuster cap nut (914 352 900 AA); outer adjuster lock nut (914 352 900 AB); small 8mm outer adjuster (914 352 423 B); large 10mm outer adjuster (914 352 423 D); inner cover o-ring (914 352 900 AC); outer adjuster c-clip (914 352 900 AD); inner adjuster (914 352 423 A); inner adjuster cap (914 352 423 C); brake pin clips (901 351 955 10); bleeder nipple (901 352 977 10); bleeder nipple cover (211 611 483); rear brake pad clip (311 615 269). Make sure you ask for the instructions.

Rear Caliper Rebuild Kit, 914-6 ... [R916 352 998 00 \\$34.50](#)

Rear Caliper Rebuild Kit, 914-4 ... [R914 352 998 00 \\$34.50](#)

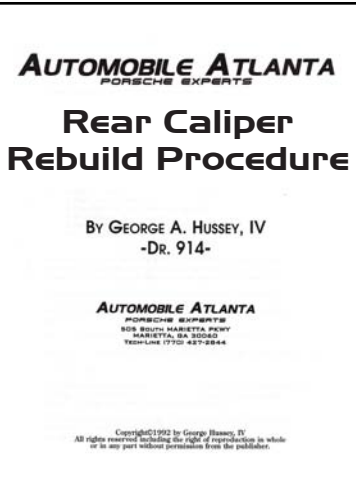

Rear Brake Caliper Rebuild Instructions

Included with Rear Caliper Rebuild Kit.

Rear Brake Caliper Rebuild Instructions

... [BTC1023 \\$11.00](#)

Zimmerman Cross Drilled Rear Rotor

Increased brake cooling for the racers! Original Zimmerman German rotors, computer drilled for maximum cooling efficiency.

Zimmerman Cross Drilled Rear Rotor ... [B914 352 401 10 \\$148.50](#)

Zimmerman Cross Drilled Rear Rotor, 914-6 ... [B901 352 401 18 \\$199.50](#)



Cryogenic Frozen Rear Rotors

These frozen rotors are the newest craze for the 914. This is a set of two. Outlast anything out there! Perfect for the racers.

Cryogenic Frozen Rear Rotors, Set of Two, 914-4 ... [RDC914 352 401 10 \\$321.00](#)

Cryogenic Frozen Rear Rotors, Set of Two, 914-6 ... [RDC901 352 401 18 \\$450.00](#)

Rear Rotor Screws

Seems like no one can ever remove those rear rotor screws without ruining them. We now have the exact replacements readily available. Buy a set and have them in stock just in case!

Rotor Screw ... [R900 269 047 09S \\$1.73/each](#)



BRAKES/WHEELS



BIG MASTER CYLINDER

When installed on a 914-4 the 914-6 master cylinder will dramatically decrease pedal travel while increasing pedal pressure. The spongy feeling will virtually disappear. Add a set of stainless lines and the spongy pedal is gone! A great combination when renewing your brakes. Bleed with ATE Blue Brake Fluid (below) and you are done!

Braking Kit ... [B914 MC \\$250.00](#)

(Includes: Master Cylinder, R911 355 012 02 911 and Stainless Steel Brake Lines, RAUT 620 034)



Ferodo Rear Brake Pad Set

Ferodo brings Formula One technology to your vehicle for better braking, less dust, no squeal and longer brake pad life. For auto-crossing and aggressive driving, we recommend Ferodo.

Ferodo Rear Brake Pad Set
... [RFCP2 \\$59.50](#)

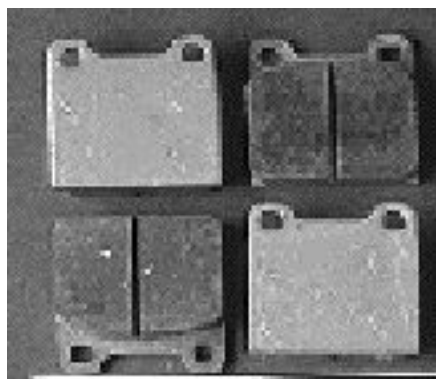

Rear Carbon Kevlar Brake Pad Set

The ultimate cool, for track and road racing. 1970-76.

914-4 ... [B914 352 923CK \\$108.35](#)

914-6 ... [B914 351 905 CK \\$120.45](#)



ATE Brake Fluid

Super Blue Racing high performance brake fluid for the extreme demands of motor racing. Thanks to its outstanding wet boiling point, it has the highest safety reserves. ATE Super Blue (DOT 4) has a dry boiling point of 536F and a wet boiling point of 396F. ATE Super Blue is identical in specification to the ATE TYP 200 brake fluid.

Super Blue Racing Brake Fluid

... [RGR 6050 \\$13.00](#)

ATE TYP 200 Brake Fluid

... [RGR 6051 \\$13.15](#)



Blue Hose For the 914 Brake Reservoir and Stainless Clamp

If its not blue, it's not brake reservoir hose and who needs brake fluid eating away at the paint? One foot length is plenty for both feeds. While you're at it, add the stainless reservoir clamp for the concours touch.

Brake Reservoir Hose ... [GN 203 501 \\$17.96](#)

Brake Reservoir Clamp ... [B914 355 907 00 \\$29.50](#)

Brake Reservoir ... [G911 355 013 13 \\$32.58](#)

Brake Line Grommet

This is the oval grommet with the nipple head for all 914 applications. Two are required for the engine shelf and two are required for the master cylinder to reservoir lines where they pass through the floor pan hump. Four required for the four cylinder models and three for the six cylinder models.

Brake Line Grommet ... [G111 957 861 \\$6.50](#)



Stainless Steel Brake Lines

Over the years, deposits form inside your rubber brake lines, creating a hard brake pedal and sticky calipers. The permanent cure is to install a set of our stainless brake lines. They are teflon-lined to prevent mineral build-up and braided stainless steel to reduce line flex! (Sold in sets of four.) Make sure you thoroughly bleed the system with some of our great ATE blue brake fluid. Make sure you specify your model when ordering.

Stainless Steel Brake Line, Set of Four

... [RBL9146 \('70-'72\) and 914-6 \\$69.95](#)

... [RBL914 \('73-'74\) \\$69.95](#)

Adjustable Proportioning Valve

For racers who have mismatched calipers, the ultimate fine tuning device is here. Easily mounted in the factory position or with line modification inside the car, just dial in your brake proportioning.

Proportioning Valve ... [RPV 9100 \\$175.45](#)

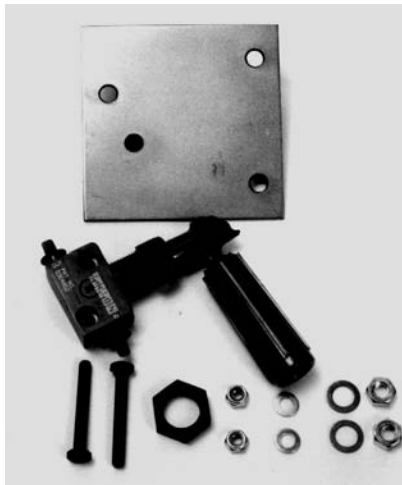

Brake Bleeder/Vacuum Tester

Does your 914 high-low idle (hunt)? Is your 914 running too rich or too lean? Do you not have an assistant to help you bleed your brakes? Does Dr. 914 ask you to measure engine vacuum or evacuate your pressure sensor when you call him for technical assistance? What you need is this handheld brake bleeder/engine vacuum tester!

Good for thousands of applications the heavy duty steel version will last the life of your tool collection. Don't be without one, and save yourself lots of time and frustration!

Metal Vacuum Tester/Brake Bleeder (Pictured)

... [RTL 2002 \\$76.95](#)

Plastic Vacuum Tester/Bleeder

... [RTL 1012 \\$43.45](#)



Power Bleeder

With a POWER BLEEDER, one person can easily, safely, and effectively bleed the hydraulic system like a professional, only cheaper! Bleeding has never been easier. There's no need for a helper to constantly pump the pedal while you open and close the bleed valves. And the 2 liter tank prevents the need for constant refilling of the fluid reservoir, thereby avoiding corrosive spills. Our precision pressure gauge prevents over pressurization and our custom machined adapter securely attaches to the fluid reservoir for the safest and most effective operation; The hand-operated pump is built in - no other pressure source (air compressor, spare tire) is needed; Fast, easy and reliable one-person operation. Works on hydraulic clutch systems, too.

Motive Power Brake Bleeder ... [RMP0104 \\$54.94](#)





KINESIS FORGED 4-LUG 17-INCH WHEEL

This is a fantastic wheel from Kinesis. Forged wheels are perfect for the Porsche 914 flared fenders. Standard annodized grey center, polished lip, 17x7 inch, fits beautifully under the front of your 914 flared fenders! Polished and annodized for a terrific finished look. Comes with standard Kinesis center caps.

Kinesis Forged 4-Lug Forged 17x7 Wheel
... [RKMK28 \\$901.95](#)

Kinesis Forged 4-Lug Forged 17x9 Wheel
... [RKMK289 \\$923.95](#)

Set of Four Kinesis 4-Lug Forged Wheels
(Either Size)... [\\$3,410.00](#)



Center Cap Remover

Never remove your hub caps with a screwdriver! Our handy tool won't mark expensive hub caps and works on all alloy hub caps with two holes.

Center Cap Remover ... [RPP0972 \\$25.24](#)



Hub Cap, Plain For Steel Wheel

This is a reproduction hub cap that fits 1970-73 914 steel wheels. Great for either dressing up the painted or chrome 15x5.5 wheel. Hub caps do not come with Porsche crest in the center but are indented in the center to accept a crest for an even dressier look.

Hub Cap ... [B473 601 151 \\$27.50](#)



914-6 Alloy or Steel Ball Seat Lug Nut

Alloy Wheel Lug Nut

... [R999 182 003 36 \\$8.25/each](#)

Steel Wheel Lug Nut ... [RN0201121 \\$6.30/each](#)



P21S Wheel Cleaner

Made in Germany and factory approved by Porsche® and other leading German automakers. Its alcohol free formula will not harm the delicate finish on your factory wheels. Spray on, spray off!

Cleaner, 1/2 Liter ... [RGR 6055 \\$17.55](#)

Cleaner, 1 Liter Refill

... [RGR 6056 \\$20.00](#)

1/2 Liter Spray-on Gel

... [RGR 6057 \\$18.65](#)

1 Liter Spray-on Gel Refill

... [RGR 6058 \\$24.20](#)

914-6 Polished Alloy Center Cap With Inlaid Color Crest Badge

Polished aluminum center cap to fit the factory 914-6 Fuchs or Mahle alloy wheels. These caps have been inlaid with a 356 style enameled hood badge for the finished look that Porsche forgot. Also available in black.

914-6 Wheel Center Cap With Crest

... [GWC1003 \\$82.44](#)

Set of Four, \$320.00



Fuchs Repro Wheel

Nothing says Classic Look like Fuchs Style Wheels on a Porsche. Do not be fooled by cheap Asian knock-offs. These Fuchs Style Wheels are high quality, cast, aluminum alloy wheels made in Italy. Designed specifically for Porsche, our Fuchs Style Wheels feature a staggered fitment front and rear.

Fuchs Repro Wheel, 16x7 ... [B914167 \\$253.00/each](#)

Fuchs Repro Wheel, 16x8 ... [B914168 \\$275.00/each](#)

Fuchs Repro Wheel, 15x6 ... [R911 361 020 00 \\$250.00/each](#)

Fuchs Repro Wheel, 15x7 ... [RAEFCS1570B \\$253.00/each](#)

Fuchs Repro Wheel, 15x8 ... [B911 360 020 93 \\$275.00/each](#)

G = Genuine • R = Aftermarket / Replacement •
U = Used • B = Rebuilt or Reproduction

BRAKES/WHEELS



914-6 HUBCAP AND HUBCAP BADGE

Heavily chromed hubcap (shown here with tri-color badge). A nice touch to any original car. Order the beautiful center badge separately.

Hubcap ... [G901 361 032 00 \\$44.72](#)

Tricolor Badge ... [R644 559 801 00 \\$27.50](#)



Polished Center Cap (Set of 4) With Inlaid Crest

Aluminum center cap to fit factory 914 4-cylinder cars. Has a 356 style enameled hood badge inlaid into the center for a finished look that Porsche forgot! Only fits OEM factory Fuchs, Mahle or Pedrini Wheel. Will not fit aftermarket replicas.

Polished Center Caps (4)
... [B914 236 97 \\$264.00](#)

Wheel Nuts and Bolts Galore!



Lug Nuts & Bolts

The special fasteners for all 914 wheels.

1. 914 Alloy Lug Bolt Repro (Acorn Style)
... [B914 361 315 01 A \\$11.00/each](#)
2. Chrome 914 Alloy Lug Bolt ... [B914 361 315 01 \\$9.50/each](#)
3. 914 Alloy Lug Bolt ... [G914 361 315 01 \\$22.54/each](#)
4. Wheel Bolt, Steel Wheels... [B183 601 139 A \\$6.50/each](#)

1974-76 Styled Steel Chrome Trim Ring Set



The chrome trim ring set is a must on the '74-76 styled steel wheel, and looks great on all the 914 steel wheels! It gives them the finished look they deserve. Heavily chrome plated, they really brighten up your 914!

4 Chrome Ring Set
... [RREP200 \\$61.38](#)



5. 914-6 Wheel Stud ... [R904 341 671 00 \\$9.18/each](#)
6. Wheel Bolt, Steel Wheels ... [G183 601 139 A \\$8.97/each](#)
7. Polished Alloy Lug Nut ... [B999 182 001 01 P \\$8.50/each](#)
8. Black-Coated Acorn Wheel Lug Nut ... [R999 182 003 36 \\$8.50/each](#)
9. Steel Ball Seat Lug Nut ... [RN0201121 \\$5.00/each](#)
10. Cap for Wheel Bolt ... [B111 601 173 \\$3.00/each](#)



Screw-In Wheel Studs

Easily convert the front or rear of your stock, non-alloy 914 wheel bolts to wheel studs, or use when converting to five lug. Just add the acorn nuts.

Wheel Studs ... [B904 341 671 00 \\$3.50/each](#)



914 Fuchs Repro

The 914 Fuchs reproduction is an exact duplicate of the most popular 914 alloy. It is constructed of highly polished aluminum with black accents and comes complete with center cap. They are counter drilled so you can use your stock lug bolts and fit as wide as a 205/60x15 tire.

Fuchs Repro, Set of Four ... [B730-5530 \\$750.00](#)

914 and 914-6 Wheel Locks

Unlike the dainty factory units that can be removed with a chisel in two seconds, McGard wheel locks are proven, reliable, and bulldog tough. McGard uses the actual lug bolt or lug nut to secure your wheels, not a flimsy cover like many other brands.

914-4 Standard Wheel Lock Set (Bolt) ... [RWL 2000 \\$43.95](#)

914-6 Wheel Lock Set (Nut) ... [RWL 2001 \\$49.50](#)

914-6 Factory Wheel Lock Set ... [R993 361 057 00 \\$59.99](#)

914-4 Alloy Wheel Lock Set (Bolt) ... [RWL 2002 \\$49.95](#)



Riviera Mag

The Riviera mag is a classic. It bolts directly to your four-lug 914 and you can fit as large as a 195/60x15 tire.

Riviera Wheel, Set of Four ... [B760 5530 \\$427.90](#)

Alloy Center Cap

Original factory issue stainless steel alloy wheel center caps never had a badge installed! Over the years tire monkeys have beaten these to death so there is no hope in finding a used one. Easily installed with a soft rubber mallet and a little grease.

Alloy Center Cap ... [G914 361 303 03 \\$34.50](#)



BRAKES/WHEELS



NEW! Fuchs 7" and 8" x 16" Four-Lug Wheels!

Porsche 914 4 lug Factory Repro Fuchs Alloys in 7, 8, & 9x16! Yes, we finally have made a Fuchs four-lug wheel in the larger widths to fit your GT conversion or just to install 7" wheels under the stock fender wells. Superb quality.

- 7" x 16" for Stock Fender ... [B914 361 011 70 \\$275.00/each](#)
- 7" x 16" for GT Front Flare ... [B914 361 011 75 \\$285.00/each](#)
- 8" x 16" for GT Rear Flare ... [B914 361 011 80 \\$285.00/each](#)

Factory Styled Steel Wheel Center Caps and Lug Nut Covers

- Lug Nut Cover ... [B111 601 173 \\$3.00](#)
- Center Cap ... [B914 361 305 00 \\$9.50](#)



Wheel Center Caps

SOLD EACH. Black plastic caps for aftermarket wheels. Measure the diameter of your opening & choose 3.25" or 2.5". Also order our colorful wheel center crest set. They fit perfectly in the center of the cap

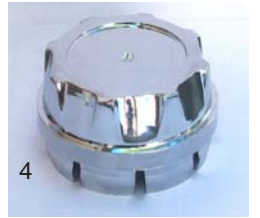

1. Black 3.25" each ... [R914 000 888 89 \\$5.78](#)
2. Black 2.5" each ... [R914 000 888 89 \\$5.78](#)
3. Silver 3.25" each ... [R914 000 888 90 \\$5.78](#)
4. Silver 2.5" each ... [R914 000 888 91 \\$6.97](#)

Porsche Hubcap Badge from the Factory!



Beautiful fired enamel crest for your steel hubcap. Direct from the factory and originally installed on the classic 356 models.

- Hubcap Badge with Crest ... [R644 559 801 00 \\$35.00](#)

INTRODUCING STEVE GAGLIONE

For 24-hour assistance and for all of you Florida folks, call our representative Steve Gaglione. A long-standing member in a leadership position with the PCA, Steve really knows his stuff. Plus, he's a great guy!



(813) 978-3433

Wheel Center Cap Decals

1.75 INCH (45MM) DIAMETER. Colorful set of four fit perfectly onto the top of the wheel center cap.

- Wheel Center Cap Decals ... [GWC100 \\$14.99](#)



770-427-2844 or 800-792-4944

WHEEL ADAPTERS

Automobile Atlanta now offers high quality wheel adapters! For years you have heard our advice against wheel adapters, until now! Finally there are high quality billet, CNC-machined, safe wheel adapters! Our new adapters are even "hub centric" so you

can enjoy precise wheel balance and no danger of breaking. Now there is a safe conversion for 4 lugs to 5 lugs without concern. Remember, wheel adapters space your wheels out one inch. Tremendous way of bolting 7" late 911 and Boxster wheels directly to your 914 with stock fender wells!

Wheel Adapters ... [RWA 9000 \\$461.95](#)

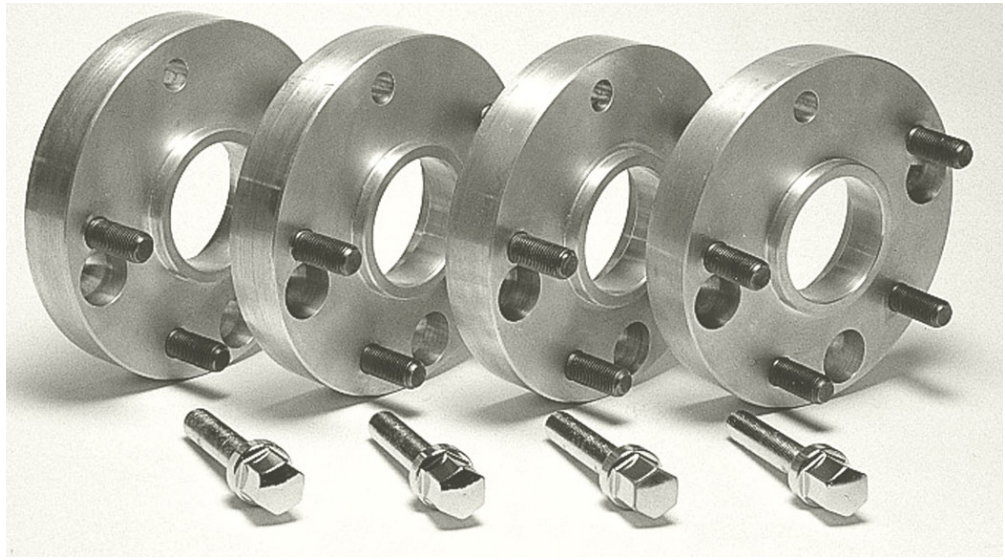

The 914 Chrome Wheel

These wheels were never factory equipment on a 914, but what a look, and very inexpensive! Wear as is or finish it off with a chrome hub cap.

Chrome Wheel ... [R914 361 012 02C \\$98.94/each](#)



Millennium Wheel, 15x7, Silver

Great 4 lug wheel for your 914. Fits beautifully under the stock fender wells. Comes in silver only.

Millennium Wheel, 15x7 ... [RRW R904C \\$319.00/each](#)

BRAKES/WHEELS



1974-76 Styled Steel Chrome Trim Ring Set

The chrome trim ring set is a must on the '74-76 styled steel wheel, and looks great on all the 914 steel wheels! It gives them the finished look they deserve. Heavily chrome plated, they really brighten up your 914!

4 Ring Set ... [RREP200 \\$61.38](#)

DRESS IT UP!

Trim Rings Snap On
In Two Minutes!



Porsche Valve Stem Cover Set

Beautiful factory valve stem covers for the final subtle elegant touch. Black with detailed Porsche® crest on silver cap.

1. Valve Stem Covers ... [GPNA 705 001 99 \\$21.16](#)
2. Complete Valve Stem Set ... [G000 044 600 00 \\$17.62](#)
3. Complete Valve Stem Set - Color ... [GPNA70500200 \\$17.93](#)



MINI-AIR COMPRESSOR

We choose this high inflation (250 psi) mini compressor because of its compact size and powerful inflation! This little device will inflate a life raft, along with your spare tire, basketball, football or bicycle tire. Plugs directly into the lighter socket and with its eleven-foot cord will reach around your Porsche! Has a build in gauge along with all of the attachments.

Mini-Air Compressor ... [BPNA113104 \\$78.14](#)



3



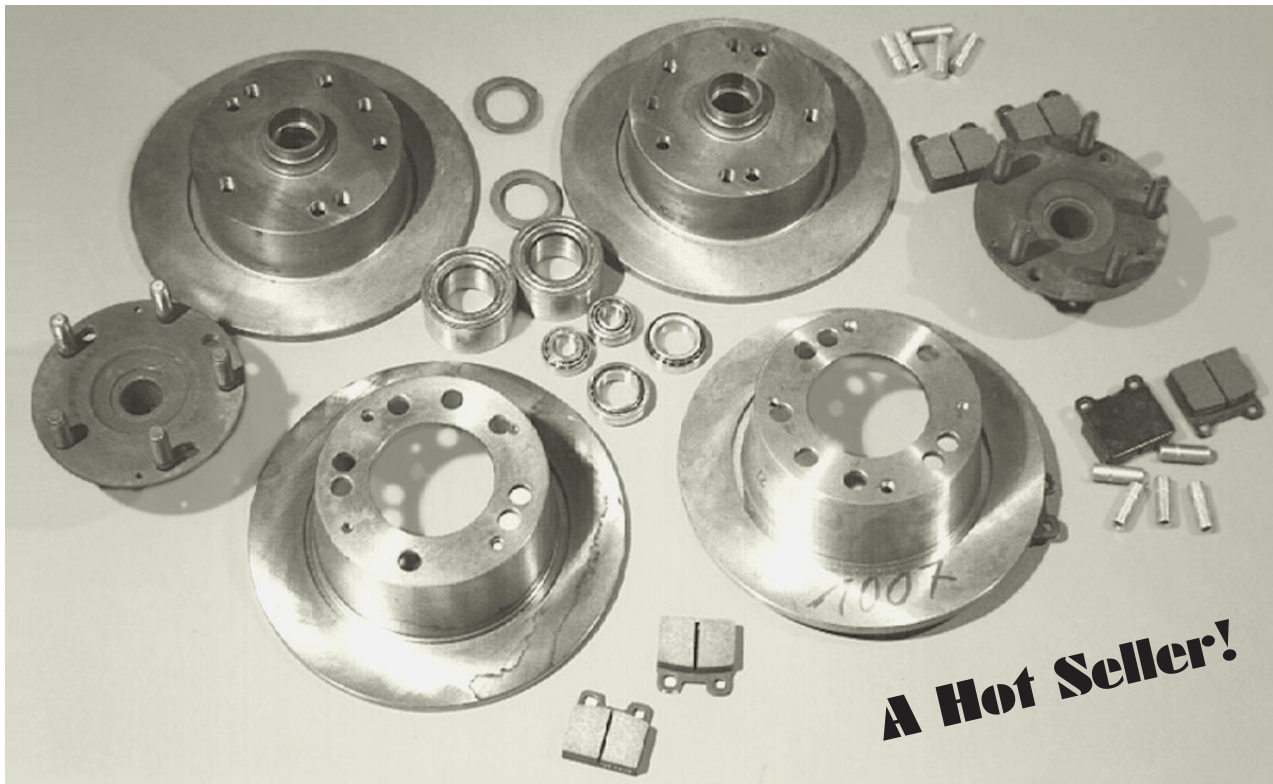

5-Lug Conversion Kit

We have done what the factory should have done to begin with, put the 911 bolt pattern on the 914! Our kit is complete with everything to do a perfect conversion, as well as a brake job and wheel bearing replacement at the same time! Core charge of \$200.00 added for your machinable rear hubs.

Kit includes:

2 Inner Wheel Bearings, 2 Outer Wheel Bearings, 2 Wheel Seals, 2 Rear Wheel Bearings, 1 Set Rear Brake Pads, 4 Drilled to 5-Lug Brake Rotors, 2 Front Wheel Seals, 2 Rear Hubs, 1 Set Front Brake Pads, 20 Studs.

911 Five Lug Conversion Kit ... [RMIS 2000 \\$852.50](#)



Empi Mag Look-Alike Wheel in Black or Polished!

These are great looking copies! They are available in black or silver polished and come with center caps. The Empe will also fit a 195/60x15 tire.

Empe Mag Black... [B710-5530 \\$439.94/Set of Four](#)

Empe Mag Silver Polished ... [R710 5530P \\$700.00/Set of Four](#)

PEDALS/LEVERS

Pedal Pads

Is the accelerator pedal wobbling from side to side or is the rod popping off the pedal cluster? You need a new one! Good for 15 years, they are all failing now. Replace yours now and you will not believe how much better your 914 drives! Replace the pedal pads while you are at it.

- Acc Pedal ... [R901 423 010 00 \\$59.50](#)
- Pedal Pad ... [R914 423 210 20 \\$3.47](#)



Cable Attachments and Hardware Parts

All of the parts Dr. 914 recommends that no one ever replaces.

1. Clevis Bushing ... [G901 423 343 00 \\$5.94](#)
2. Clevis Pin ... [R999 166 001 02 \\$7.50](#)
3. Clevis Fork ... [R900 166 002 02 \\$7.50](#)
4. Banjo Clip ... [G914 423 283 00 \\$5.27](#)
5. Clutch Cable Boot ... [G914 423 922 02 \\$8.42](#)
6. Clutch Cable Wedge ... [G911 423 205 03 \\$21.83](#)
7. Clutch Cable Nyloc ... [N0 211 931 \\$2.00](#)
8. Accelerator Rod Ball Socket ... [G900 169 012 02 \\$8.47](#)
9. Heater Control Cable, Barrel Nut or Acc Cable ... [G111 129 921 \\$9.49](#)

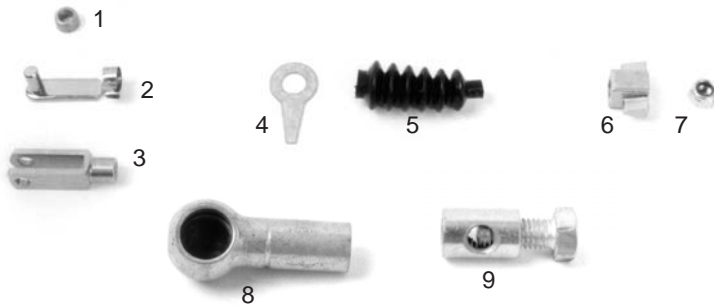

Rebuilt Pedal Cluster

Tried to dismantle your pedal cluster to install new bushings and found that it is impossible to drive out the roll pin? Join the crowd! Time for a rebuilt cluster. All of our rebuilt clusters are completely dismantled, sand-blasted, meticulously painted, and reassembled with silicone bronze bushings. CORE CHARGE \$150.

- Rebuilt Pedal Cluster ... [B901 423 015RB \\$275.00](#)



Street Aluminum Pedals

These highest quality pedal covers have been designed to give you ultimate pedal control and comfort. The dead pedal is the largest available and gives your left foot plenty of surface area to grip when maneuvering through those hard turns. Our pedals all have a raised surface treatment that forces superior foot adhesion. Matches adjustable accelerator pedal. Pedal sets are constructed of aircraft grade aluminum and all stainless steel hardware.

- 4 Piece Aluminum Pedal Set ... [RRL 342 62 \\$383.90](#)

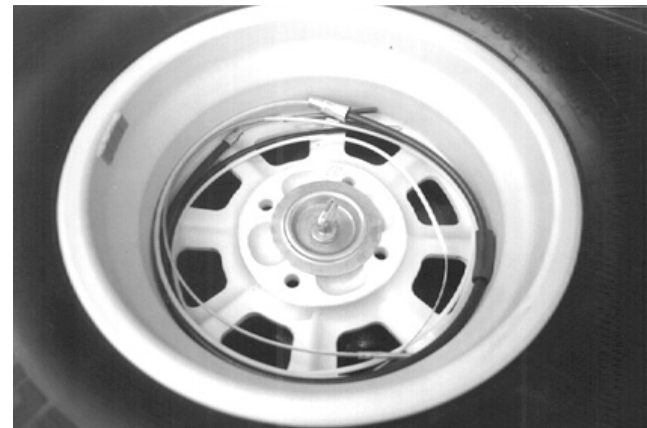

914-4 Accelerator & Clutch Cable Set

Have you ever been left stranded on the side of the road due to a broken clutch or accelerator cable? If not, you're due! Be safe, not sorry. Our cable set curls up neatly in the spare and costs less than a tow bill!

- Cable Set ... (Consists of R914 424 067 02 and R914 424 401 05) \$40.42

Pedal Cluster Rebuild Parts

Want to rebuild it yourself? We have the parts! The Rebuild Kit comes complete with instructions.

1. Pedal Cluster Bushing Kit ... [RBP 900 \\$23.10](#)
2. Clutch Pedal Spring ... [G901 423 317 00 \\$7.99](#)
3. Brake Pedal Spring ... [G901 423 531 00 \\$30.88](#)
4. Clevis Fork ... [R999 166 002 02 \\$7.50](#)
5. Clevis Pin ... [R999 166 001 02 \\$7.50](#)
6. Accelerator Pedal ... [R901 423 010 00 \\$59.50](#)
7. Pedal Pad ... [R914 423 210 00 \\$5.20](#)
8. Pedal Cluster
... [B901 423 015 RB \\$275.00 \(core charge \\$150.00\)](#)



Reproduction 5-Speed Shift Knob

Great reproduction of the factory original. In keeping with the factory tradition we are proud to offer this beautiful factory-look shift knob, which duplicates the original long discontinued Porsche original but with a billet aluminum shift pattern insert! Manufactured from high strength delrin plastic the knob fits all 911 1965-71, 912 1965-76 and 914 1970-76. This knob is so good that it will pass for concours application as the judges will appreciate your effort at factory tradition!

- Reproduction 5 speed knob
... [B901 424 014 00 \\$74.50](#)
Shift Knob Crush Sleeve (to install)
... [B999 532 001 00 \\$4.50](#)

Short Shift Kit

If your early model shifter is still not precise enough after your rebuild, install our short shift kit. It will make your shifter almost as precise as the '73-76 914! It is easily installed and comes with complete instructions.

- '70-72 Short Shift Kit ... [RSK1 \\$69.95](#)
'73-76 Short Shift Kit ... [RSK3A \\$69.95 \(Pictured\)](#)

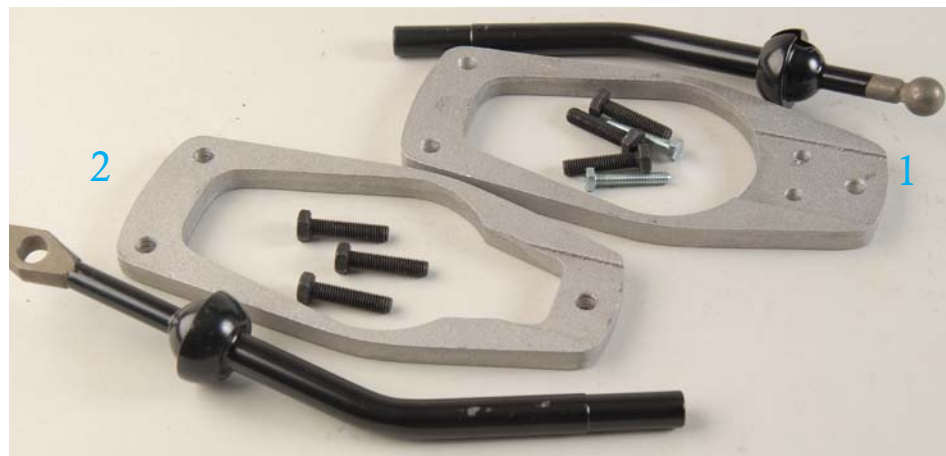

Weltmeister Short Shift Kit

Complete with a new black shift rod, this short shift kit works well for the racer. Raises the carpet hump approximately 1/2 inch. The advantage of this one over the RSK 3A is that you do not have to separate the shift lever from the fulcrum at the bottom: it's all one piece. A far easier and time-saving solution!

- 1970-72 Short Shift Kit ... [RSK 9000 \\$118.74](#)
1973-76 Short Shift Kit ... [RSK 9001 \\$118.74](#)



PEDALS/LEVERS

914 Shift Bushings to Stop Mis-Shifts

Slop in your shifter? Hit reverse instead of 2nd? Try re-bushing your shifter! Our kits are complete and easily installed. (Larger kits include shift base bushings.)

BMIS 4000 ... [4 Piece '70-72 Kit \\$50.00](#)

BMIS 4100 ... [8 Piece '70-72 Kit \\$82.50](#)

BMIS 4200 ... [3 Piece '73-76 Kit \\$33.00](#)

BMIS 4300 ... [5 Piece '73-76 Kit \\$49.50](#)

BMIS 4301 ... [7 Piece '73-76 Kit \\$82.50](#)

BMIS 4400 ... [4 Piece 914-6 Kit \\$49.50](#)

1. 70-72 Lower Shift Lever Bushing ... [G901 424 135 00 \\$6.48](#)

2. 70-76 Upper Shift Lever Bushing ... [G901 424 132 00 \\$6.84](#)

3. 70-72 Ballbushing ... [G914 424 512 00 \\$12.08](#)

4. Ballcup Bushing ... [R911 424 139 00 \\$10.39](#)

5. 73-76 Shift Pivot Bushing ... [G911 424 223 03 \\$34.62 \(Repro \\$16.00\)](#)

6. 70-76 Crown Bushing ... [G914 424 224 02 \\$11.72](#)

7. 70-72 Firewall or Front or Rear Shift Bushing ... [R914 424 224 00 \\$16.16](#)

*8. Early to Late Firewall Conversion Bushing ... [G914 424 224 AA \\$21.45](#)

9. 73-76 Shift Firewall Bushing ... [G914 424 224 03 \\$13.85](#)

10. Late Lower shift Lever Bushing ... [G914 424 343 00 \\$14.16](#)

*(Firewall conversion bushing needed when installing late model shift linkage in an early 1970-72 914).

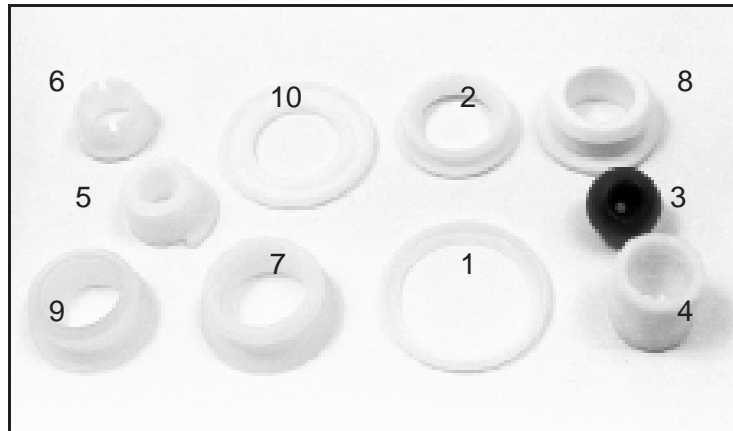

914 Shifter Rebuild Kit To Solve 1970-72 Shift Slop

We have solved the sloppy '70-72 shifter with our rebuilt unit! It incorporates the amazing short shift kit and contains all parts needed to completely replace your shift mechanism with new and rebuilt parts. Contains: Rebuilt front short shifter, Rebuilt front & rear shift bars, Rebuilt trans selector rod, All bushings, covers, and boots. Core charge \$300.00

Shifter Rebuild Kit ... [B914 424 001 \\$434.50](#)

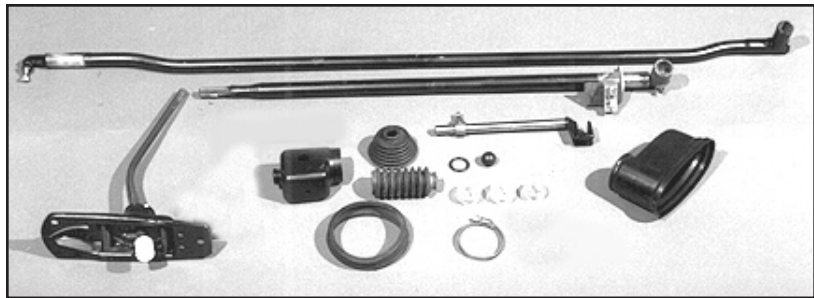

914 Leather Shift Boot

After all, the stock rubber factory boot is plain looking! Rich leather, and a perfect fit.

Leather Shift Boot ... [R914SB \\$65.95](#)

Early to Late Shift Linkage Conversion Kit

Everything you need to convert the sloppy early linkage to the late factory perfected set-up. Easily installed by an experienced home hobbyist in several hours, this is the ultimate 914 shifting solution. Core charge \$300.00

914-4 Kit ... [BSLC 9144 \\$750.00](#)

914-6 Kit ... [BSLC 9146 \\$750.00](#)



Emergency Brake Boots

1. Long (Front)

... [G914 423 593 00 \\$10.66](#)

2. Small (Rear)

... [G914 424 591 00 \\$7.60](#)



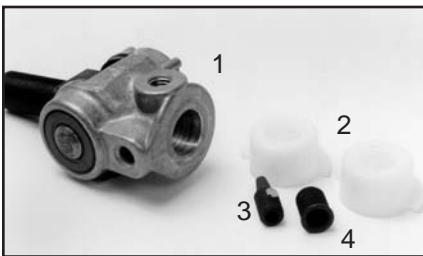

Shift Coupler/ Threaded Insert Shift Set Screw

Have a broken or stripped shift coupler? Never fear. New parts are here!

1. '73-76 Shift Coupler ... [R911 424 024 04 \\$112.15](#)
2. Shift Coupler Bushing (2 req) ... [B911 424 223 03 \\$16.00](#)
3. Set Screw (2 required) ... [R901 424 229 00 \\$4.43](#)
4. Set Screw Repair Insert ... [RW663 \\$8.09](#)



U-Joint Coupling Bushings

Always neglected and forgotten, these tough little guys are failing after almost 30 years and causing all kinds of shifter slop. Factory replacements or excellent reproductions - your choice. (2 required.) Beware of cheap imitations! They have slop!

Original Bushing ... [B911 424 223 03 \\$16.00/each](#)



916 Shift Kit

Perfect by our shop, this is the ultimate shifting connection for your 916 transmission conversion. After miles of quick shifting at the track and continued modification, we have perfected this kit. Core charge \$300.00.

916 Shift Kit ... [BSK 916 \\$950.00](#)



Emergency Brake Lever

Avoid purchasing a costly new emergency handle with these handy repair parts. A little labor and voila, a brake handle that works like new!

1. Emergency Brake Lever ... [G914 424 053 01 \\$219.14](#)
2. Emergency Brake Equalizer Cable ... [G914 424 256 00 \\$92.12](#)
3. Emergency Brake Pin ... [G914 424 571 00 \\$4.87](#)
4. Emergency Brake Clip ... [GN012 6452 \\$2.00](#)
5. Driver-Side Emergency Brake Cable ... [R914 424 551 01 \\$51.97](#)
6. Passenger-Side Emergency Brake Cable ... [R914 424 552 01 \\$51.97](#)

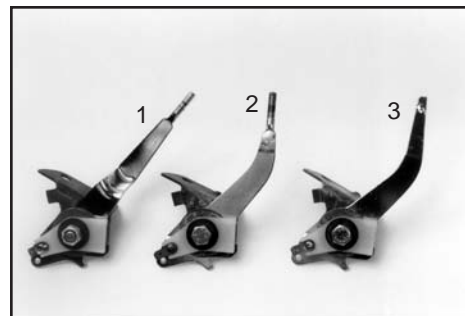

Heater Switches

Straight screw-on knob 1970-71 and 1973-76, straight press on "defrost" knob, and 90° 1972 bent screw on knob for console equipped cars.

1. 1973-76 914 with Console ... [U914 424 073 02 \\$275.00](#)
2. 70-71 and 73-76 914 ... [G914 424 073 04 \\$57.79](#)
3. 1972 with Defrost Emblem ... [G914 424 073 04 \\$57.79](#)



Accelerator Cable And Heater Control Barrel Nut

They look similar but are not, and when lost, cause a heck of a problem. Buy extras just in case!

Accelerator Barrel Nut ... [G111 129 921 \\$9.49](#)
 Heater Control Cable Barrel Nut (2 Required) ...
 G311 129 777 \$7.79/each

THE 914 BODY

Front Floorpan

The front half of the floor pan is for you Yankees with a real rust problem and covers from the front of the lateral reinforcement under the seats to the back of the pedal cluster.

Front Floorpan ... [BRP 1462 \\$192.50](#)

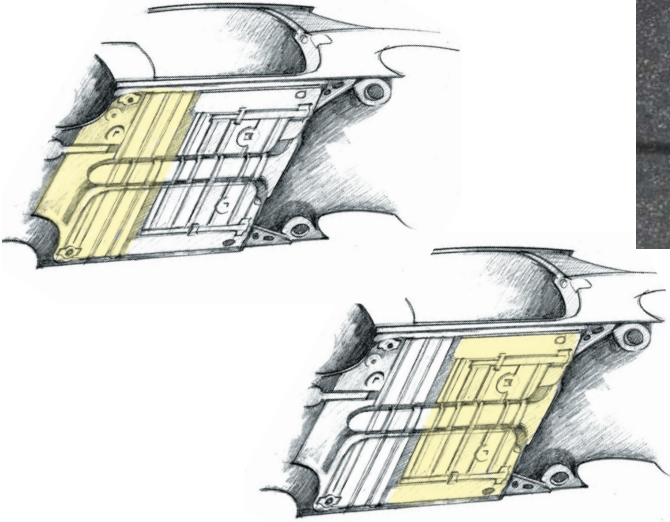

Rear Floorpan

The rear half of the floor covers from the rear firewall to just in front of the reinforcement under the seats. Does not include seat hinge stand, available on p. 84.

Rear Floorpan ... [BRP 1463 \\$192.50](#)

Left and Right Floorpan

Left half covers from the rear firewall to the front firewall to the middle of the center tunnel and includes the pedal cluster reinforcement. The right half covers from the rear of the firewall to the front firewall to the middle of the center tunnel. Comes complete with seat hinge stand.

Left Floorpan (Shown) ... [RSIC 501 939 00 \\$225.00](#)

Right Floorpan ... [RSIC 501 940 00 \\$225.22](#)

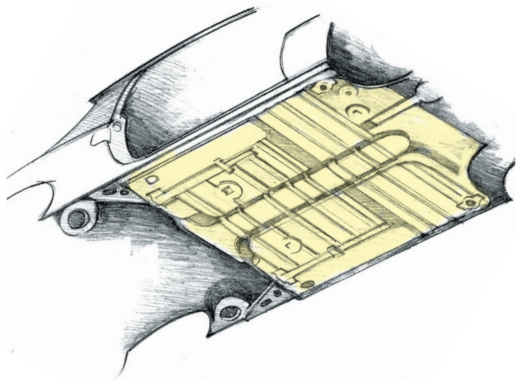

Floor Pan Triangles

The left and right rear floorpan triangles provide reinforcement to the floorpan and give you a nice fresh jacking point for a floor jack or car lift. Part includes the jacking donut.

Right Triangle ... [B914 507 042 10 \\$82.50](#)

Left Triangle ... [B914 507 041 10 \\$82.50](#)

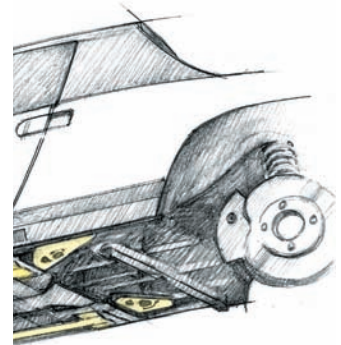

Original Colors Chart

Touch up now available! Custom mixed and in a handy applicator bottle, order by paint code.

Touch Up Paint (state color) ... [\\$12.50](#)

NOTE:

To find the original color number of your 914, look at the Karmann plate in the driver's front door jamb. It will contain both the karmann body number and below it, the factory color number (*kunstharzlack*), ie: L32K.

Karmann Body Plate ... [B914 701 105 00 \\$19.50](#)

4-Piece Rivet Kit ... [B900 055 003 30 \\$5.00](#)



B3v9 L13K e5v9 L20c h5v9 L30c 1610 150c 1510 160e 4310 163k



MANUFACTURED BY VOLKSWAGENWERK AG
THIS VEHICLE CONFORMS TO ALL APPLICABLE FEDERAL MOTOR VEHICLE SAFETY STANDARDS IN EFFECT ON THE DATE OF MANUFACTURE SHOWN ABOVE.
GVWR LB. 2690
GAWR LB. FRONT 1433/REAR 1433

1970: 914, SOME 914/6

Color	Number	Code
Tangerine	2310	L21E
Metalic Red*	8110	L97D
Canary Yellow	2910	L11E
Signal Orange	1410	L20E
Light Ivory	1110	L80E
Irish Green	1510	L60E
Metallic Green*	8310	L97P
Metallic Blue*	8410	L98P
Adriatic Blue	1610	L50E
Silver Metallic (2-coat)*	8010	L96D
Gemini Blue*	8610	L96E

1971: SOME 914/6

Color	Number	Code
Tangerine	2310	081
Bahia Red	1310	022
Canary Yellow	2910	115
Signal Orange	1410	116
Light Ivory	1110	131
Irish Green	1510	213
Willow Green	4310	223
Adriatic Blue	1610	327
Gemini Blue*	8610	330
Silver Metallic (2-coat)*	8010	925
Gold Metallic*	8810	133

1974

Color	Number	Code
Light Ivory	B8V9	L80E
Bahia Red	G2V9	L30E
Sunflower Yellow	B3V9	L13K
Ravenna Green	M5V9	L65K
Olympic Blue	J8V9	L51P
Phoenix Red	G5V9	L32K
Zambezi Green	M7V9	L64K
Saturn (Chrome) Yellow	B2V9	L13M
Black*	A1V9	L04I
Delphi Green Metallic*	W1V9	L99A
Marathon Blue Metallic*	X2V9	L96M
Alaska Blue Metallic*	X4V9	L96B
Silver Metallic*	Z2V9	L96D

1970: SOME 914/6

Color	Number	Code
Tangerine	2310	015
Metalic Red*	8110	021
Canary Yellow	2910	115
Signal Orange	1410	116
Light Ivory	1110	131
Irish Green	1510	213
Metallic Green*	8310	221
Metallic Blue*	8410	324
Adriatic Blue	1610	327
Silver Metallic (2-coat)*	8010	925
Gemini Blue*	8610	330

1972

Color	Number	Code
Saturn (Chrome) Yellow	2610	L13M
Signal Orange	1410	L20E
Tangerine	2310	L21E
Bahia Red	1310	L30E
Black*	1010	L04I
Adriatic Blue	1610	L50E
Irish Green	1510	L60E
Willow Green	4310	L63K
Light Ivory	1110	L80E
Silver Metallic*	8010	L96D
Gemini Blue*	8610	L96E
Gold Metallic*	8810	L97G

1975

Color	Number	Code
Berber Yellow	B5V9	L11D
Summer (Sunflower) Yellow	B3V9	L13K
Nepal Orange	E5V9	L20C
Malaga Red	H5V9	L30C
Scarlet (Mars) Red	H3V9	L31M
Black*	A1V9	L31M
Lagoon Blue	J1V9	L50C
Forest Green	M7V9	L64K
Light Ivory	B8V9	L64K
Palma Green Metallic*	Y1V9	L95K
Silver Metallic*	Z4V9	L96D
Ancona Blue Metallic*	X5V9	L97B
Copper Metallic*	W2V9	L99K

1971: 914, SOME 914/6

Color	Number	Code
Tangerine	2310	L21E
Bahia Red	1310	L30E
Canary Yellow	2910	L11E
Signal Orange	1410	L20E
Light Ivory	1110	L80E
Irish Green	1510	L60E
Willow Green	4310	L63K
Adriatic Blue	1610	L50E
Black*	1010	L04I
Silver Metallic (2-coat)*	8010	L96D
Gemini Blue*	8610	L96E
Gold Metallic*	8810	L97G

1973

Color	Number	Code
Light Ivory	B8V9	L80E
Bahia Red	G2V9	L30E
Olympic Blue	J8V9	L51P
Saturn (Chrome) Yellow	B2V9	L13M
Phoenix Red	G5V9	L32K
Ravenna Green	M5V9	L65K
Zambezi Green	M7V9	L64K
Sunflower Yellow	B3V9	L13K
Signal Orange	E2V9	L20E
Black*	A1V9	L04I
Delphi Green Metallic*	W1V9	L99A
Marathon Blue Metallic*	X2V9	L96M
Alaska Blue Metallic*	X4V9	L96B
Silver Metallic*	Z2V9	L96D

1976

Color	Number	Code
Summer (Sunflower)Yellow	B3V9	L13K
Nepal Orange	E5V9	L20C
Malaga Red	H5V9	L30C
Scarlet (Mars) Red	H3V9	L31M
Black*	A1V9	L31M
Lagoon Blue	J1V9	L50C
Light Ivory	B8V9	L64K
Viper Green Metallic*	Y5V9	L96N
Silver Metallic*	Z4V9	L96D
Ancona Metallic*	X5V9	L97B

Colors followed by an asterisk (*) are those that were available at extra cost, i.e. metallics and black.

History: A custom paint color (paint to sample) was additionally optional for only \$136.50.

THE 914 BODY

Cross Member Repair

Unable to stomach the \$800.00+ price of the factory cross member, especially when only one side is rusted? Our exact reproduction stamping fits the bill perfectly!
Order left or right.

Cross Member Repair, Left

... [B914 501 109 10 \\$110.00](#)

Cross Member Repair, Right

... [B914 501 110 10 \\$110.00](#)

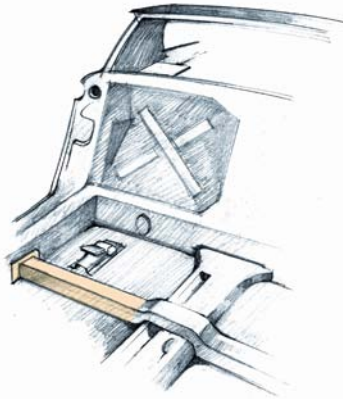

Floor Pan Tar

The original German made material in heatable-beatable sheets. When installed, it duplicates the original sound deadening for the perfect concours look. One package completes one side. Better yet, order our Floor Pan Tar Premade Kit on the next page!

Floor Pan Tar ... [BWU 890 100 \\$51.70](#)

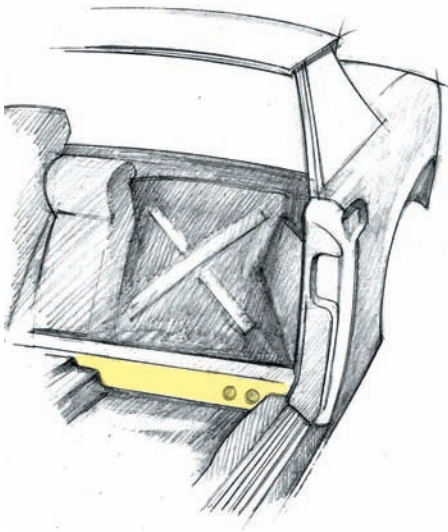

Inner Firewall

Battery acid or a leaking window rust the inner firewall every time. No wonder your emergency brake doesn't work!

L Driver's side ... [B914 501 643 15 \\$104.50](#)

R Passenger Side ... [B914 501 644 15 \\$104.50](#)

2-Piece Kit ... [BP 325 \\$192.50](#)



Wurth Brushable Seam Sealer, Quart

The factory uses gallons of this when they build their German automobiles. If you do any body repairs or replace a fender, make sure it is resealed for a proper repair. Prevents rust and corrosion.

Wurth Brushable Seam Sealer, Quart ... [RGR1019 \\$36.78](#)

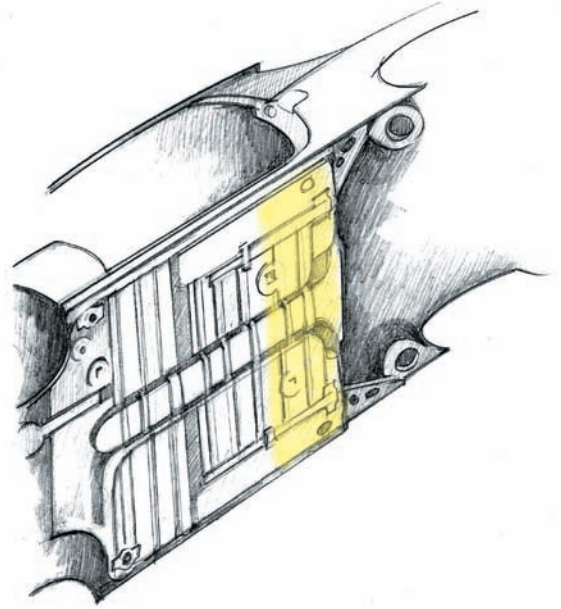

Shorty Floorpan

Replaces area just in front of the seat hinge back. For the Southern or California rust free car with a leaking battery or leaking rear window, this exact duplicate of the factory original. It covers the area from the rear firewall to in front of the seat hinges and it is easily installed. Make sure you install the floor pan tar kit, and use seam sealer and chip guard.

Rear Floorpan Patch ... [B914 501 939 25 \\$110.00](#)

Würth Stone Guard

Buy it in black and if you practice your spray technique, you can exactly duplicate the top finish with this excellent product. Buy it in beige and coat underneath after replacing the pans. Paint either to match for an excellent factory looking job. 17 oz. can.

Black Stoneguard ... [RGR 1015 \\$16.28](#)

Grey Stoneguard ... [RGR 1016 \\$16.28](#)

Beige Stoneguard ... [RGR 1017 \\$16.28](#)



Floor Pan Tar Premade Kit

Now, a perfect premade solution to installing the floor pan insulation over your freshly installed floor pan. These custom kits are made exclusively for us by our friends at Dynamat and are a perfect fit. Now floor pan insulation installation is a breeze!

Floor Pan Tar Premade Kit

... [B914 556 110KT \\$175.00](#)

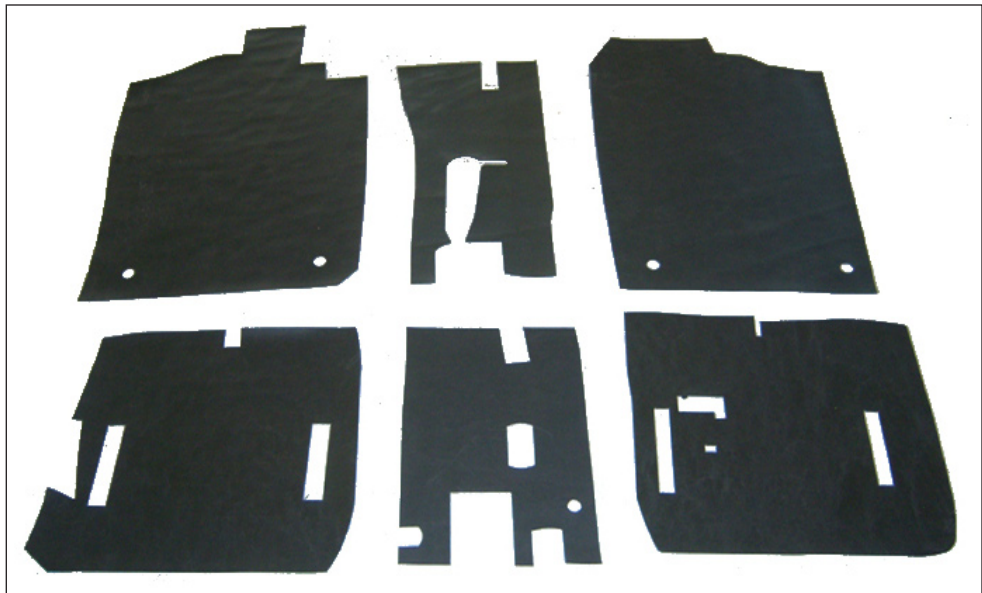

THE 914 BODY

Floor Pan Hinge Reinforcement

This U-channel reinforces the outer hinges and is easily welded to the bottom of your freshly installed floorpan. Never available separately from the factory.

Floor Pan Hinge Reinforcement ... [B914 501 943 00 \\$27.50](#)

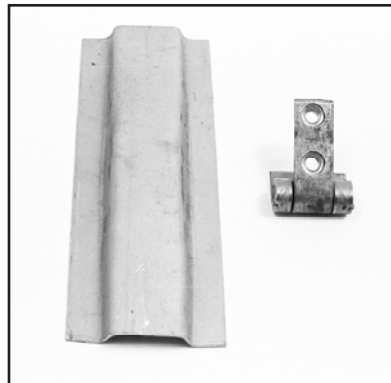
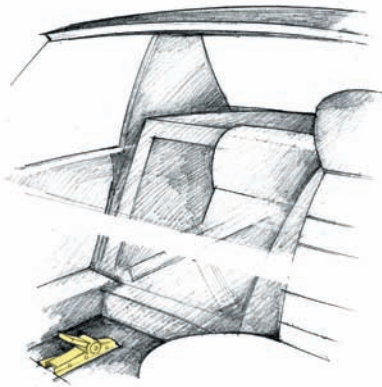
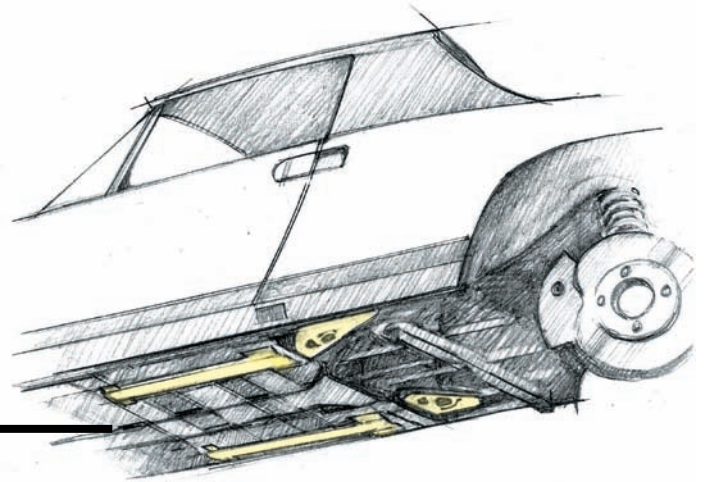
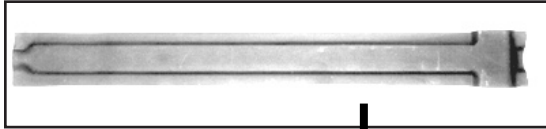

Seat Hinge Bracket

Is your seat loose due to rusted seat brackets that are unavailable from any source? Look no further: We have them! Identical to the ones originally welded to the factory floor pan, they make a perfect repair. (2 piece kit pictured.)

Seat Bracket ... [B914 501 937 82 \\$49.50](#)

Jacking Donut

Sold each. There are four of them on the 914 floor pan. They provide great support for jacking and/or jackstands. Easily spot welded in.

Jacking Donut
... [B914 507 041AA \\$38.50](#)



Longitudinal Member Inner Right Frame Repair Kit, 2-piece

Longitudinal under the battery repair: AT LAST! A reasonably priced set of repair panels for the right frame rail! Ever wonder why your 914 sags on the passenger side or the door sticks when opening? The frame is rusted! (and most probably from battery acid!) Automobile Atlanta's exclusive two piece frame repair kit solves the problem and returns the strength to your 914! The original part is over \$2,350.

Longitudinal Member Inner Right Frame Repair Kit, 2-piece, 914

... [B914 501 434 10 \\$439.45](#)

Longitudinal Member Inner Right Frame Repair Kit, 2-piece, 914-6

... [B914 501 010 10 \\$439.45](#)

Rocker Clamshell Set of Two

Easily restore the strength to your 914 chassis with our rocker clamshells. Designed to install over the rusted area, clamshells make chassis reinforcement easy or for you racers, the ultimate in chassis stiffening. Clamshells make such a perfect fit you can actually use them to realign your frame. Avoid costly restoration and save a 914! Complete with instructions.

Rocker Clamshell ... [B914 501 013 14 \\$350.00](#)

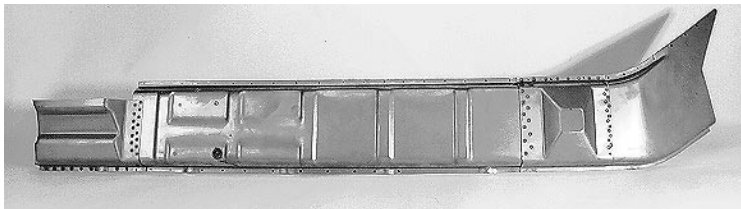

Rear Trunk Floor

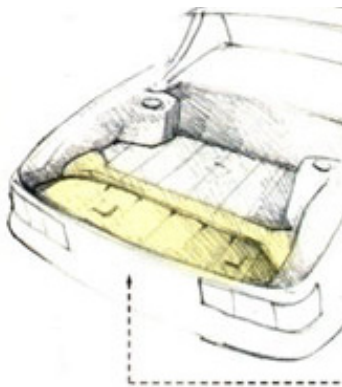

Now a solution to the rusted rear trunk floor! Most 914 trunk floors by now have rusted from years of taillight leaks. Our repair panel is everything you need for a perfect factory repair without purchasing the \$2100.00 factory assembly! It is large enough that it extends in front of the brace

Rear Trunk Floor ... [B914 501 083 20 \\$192.50](#)

Emergency Brake Pivot

Superb reproduction of the no longer available original factory part. Easily welded in.

Emergency Brake Pivot ... [B914 501 075 10 \\$65.00](#)



Engine Shelf

Want to replace your battery tray and support, but you see the shelf under it is rusted? You need our replacement shelf. We manufacture this great item, which also mounts the fuel pump and holds the engine to body seal. Easily welded in, it completes a perfect battery area repair. Order some new fuel pump mounts and fuel line grommets while you are at it, and coat with POR-15 rust conversion paint before top coating.

Engine Shelf ... [B914 501 436 12 \\$192.50](#)

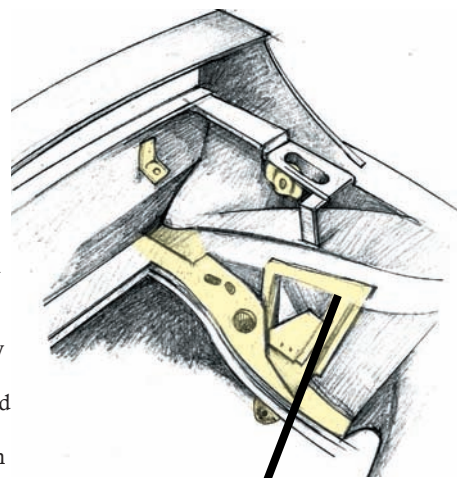

Can't do it yourself?
Let our highly skilled 914 experts do it for you. Call (770) 427-2844 to set up a restoration appointment!

Engine Bay Channel

Driver or passenger side. S-shaped channel to hold the engine bay seal on the passenger or drivers side, easily spot welded into place. Is included with the engine shelf replacement. Make sure that you order a new engine bay seal for this part while you are at it!

Engine Bay Channel ... [B914 501 825 10 \\$38.44](#)

THE 914 BODY



Engine Shelf Plug

For 914-6. Discontinued by Porsche, but limited availability at 914 World Headquarters! Great repro!

Engine Shelf Plug ... [B914 559 243 10 \\$9.50](#)



Right Rear Suspension Console

Beautiful piece! Stamped from our high quality steel tooling this piece replaces the inner passenger suspension mount that often breaks loose from battery acid damage. Easily welded in after engine and swing arm removal, order our rust conversion paint seam sealer and engine shelf for a perfect repair.

Right Rear Suspension Console

... [B914 501 044 11 \\$192.00](#)

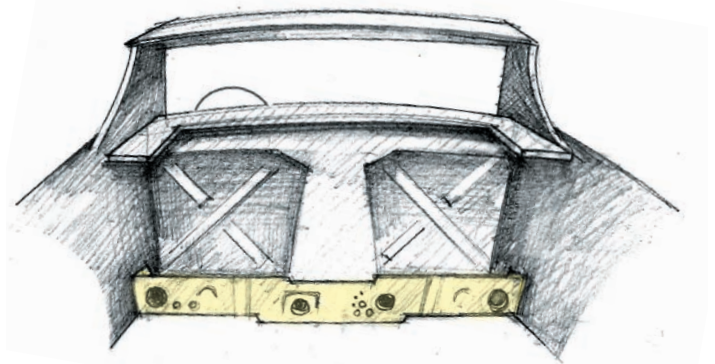
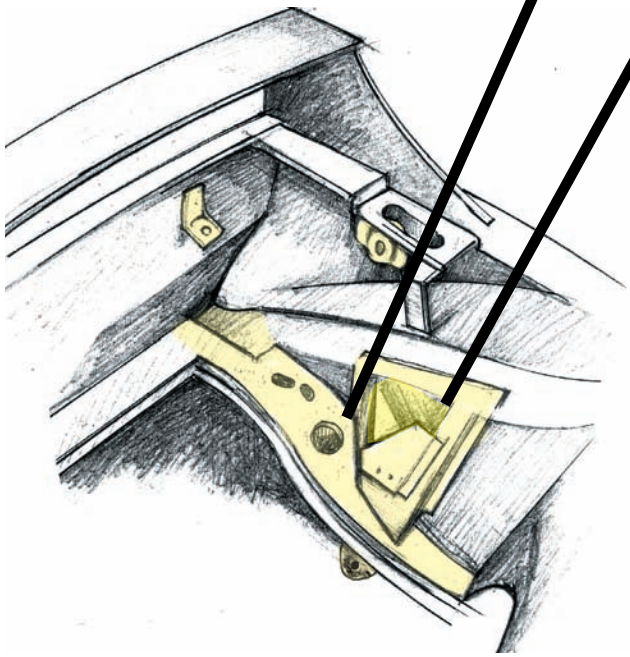

PART NEEDS SLIGHT
MODIFICATION TO FIT 1970-72
MODELS' SHIFT LINKAGE



Outer Firewall

If the outer firewall is rusted, we have fabricated the part to repair the area perfectly. Tested in our Restoration Shop, this piece saves hours of costly fabrication and returns the area to the stock look without replacing the complete factory part.

Outer Firewall ... [B914 501 119 20 \\$155.00](#)

Our restoration department does superb paintwork! Call today for your appointment.
(770) 427-2844

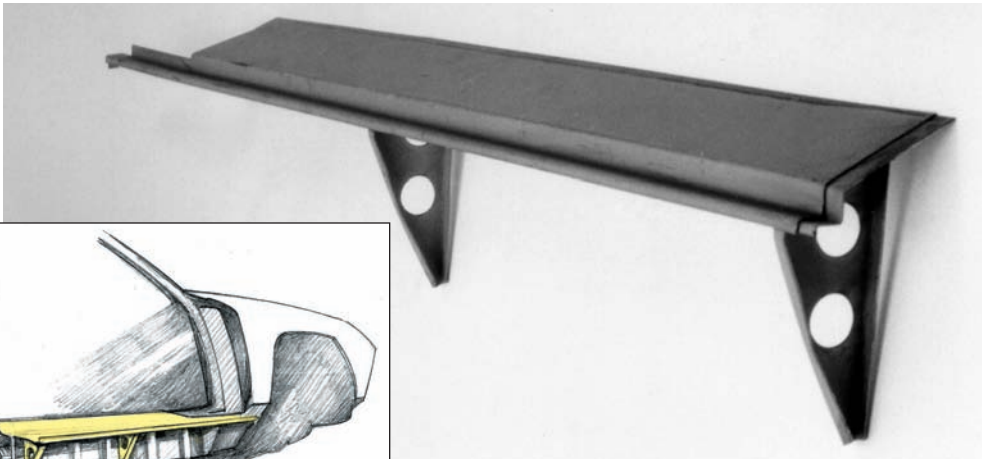
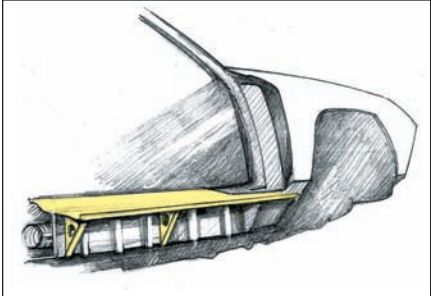

Sill Threshold Plates

If you notice bubbling at the back of the threshold plate where it meets the rear quarter panel, the sill is rusted. If you remove the brushed aluminum or black plastic threshold, you will probably see additional damage. Our sill completely solves the problem and is easily welded in.

- Left Sill Plate ...**
- B914 501 089 10 \$93.50**
- Right Sill Plate**
- ... [B914 501 090 10 \\$93.50](#)**
- A. Sill Triangle Only (included w/sill plate) ... [B914 501 000 10 \\$16.50](#)**

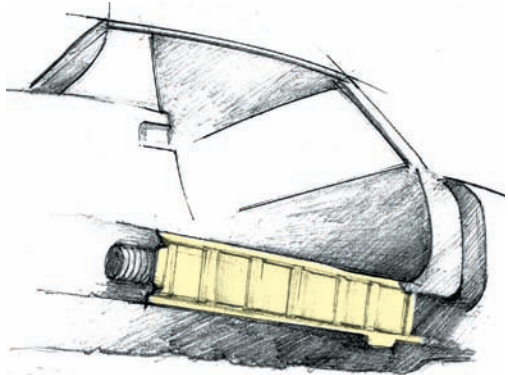

Inner Rocker Panel

When the inner rocker rusts, the 914 sags. Welding in a new one restores the strength to the frame and saves your 914.

- Left Inner Rocker ... [B914 501 013 10 \\$150.00](#)**
- Right Inner Rocker ... [B914 501 014 10 \\$150.00](#)**



Jack Post & Support

The jack post and support completes your frame restoration and restores use of the factory jack. They are easily welded in!

- A. Support ... [B914 501 151 10 \\$19.50](#)**
- B. Post ... [B914 501 153 10 \\$22.00](#)**
- Buy Both and Save!**

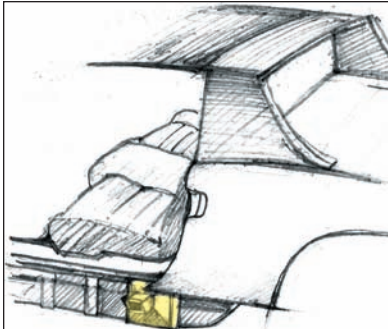

note: if your 914 is rusted under the jack post and support, you need to order the lower wheelhouse on page 88

Rear Deck Hinge Pivot

Is your rear deck high on one front corner? You have broken the hinge pivot for lack of lubrication to the shoulder bolt! These are easily welded in once you relieve the spring pressure on the hinge roller! Ask for the free replacement guide when you order this part!

- Hinge Pivot ... [B914 501 030 10 \\$24.20](#)**
- Shoulder Bolt ... [B914 512 191 10 \\$9.90](#)**

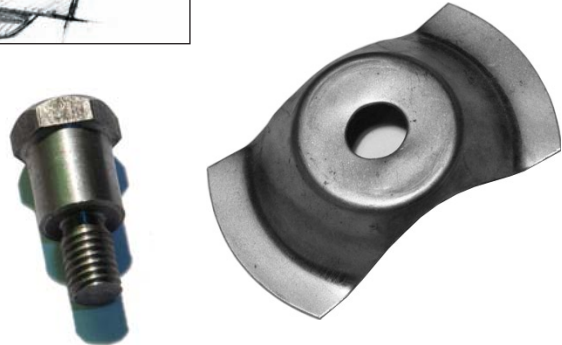

THE 914 BODY

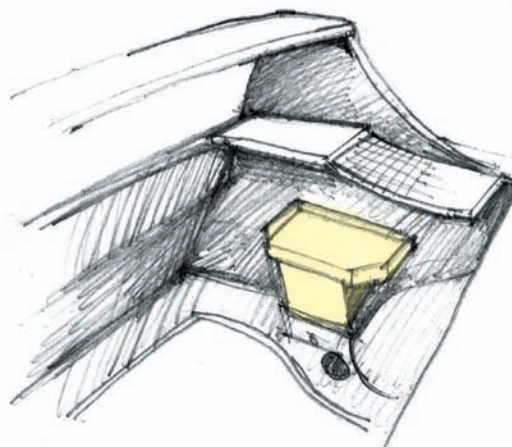

Battery Support Kit

914s have suffered from battery acid damage for years. They eventually all need a new tray and support. Easily welded in, when these parts are painted with polyurethane paint and you install one of our heavy duty battery covers and battery tray mats, the chances of this happening again are greatly reduced.

Battery Mat ... [RGR 5010 \\$10.97](#)

Clamp & Bolt ... [B914 611 233 10 \\$8.25](#)

Support ... [B914 501 073 10 \\$26.95](#)

Tray ... [B914 501 587 10 \\$55.00](#)

Cover (Genuine) ... [G281 915 411 E \\$21.18](#)

Cover (Repro) ... [B281 915 411 E \\$13.20](#)

Buy All Five (With Repro Cover) ... [RBK 501 \\$88.00](#)

Right Inner Wheel House

At last, a solution to right frame rail rust. The inner rocker solves the problem from the jack post to the front, but what about under the jack post to the rear? The solution is our Right Inner Wheel House Repair Panel. It solves both right rear frame rot as well as the behind the battery tray rust-through. Easily welded in, it restores these areas' strength, as well as the stock appearance. Pieces overlap for extra strength.

Right Inner Wheel House ... [B914 501 944 20A \\$175.00](#)

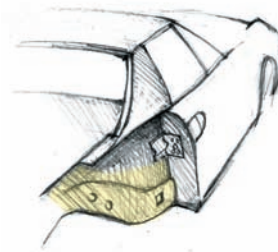

Chassis Stiffening Kit

The Chassis Stiffening Kit is a must for ultimate handling—both the 914-6 GT and the 916 had them installed by the factory. You will never know what you've missed until you drive one with and then without the kit. The *with* is so much more definite in a hard corner, not suffering the chronic 914 flex. The kit is comprised of ten pieces, and installation entails removal of the swing arms to weld in place.

Chassis Stiffening Kit

... [RCS 1006 \\$185.00](#)

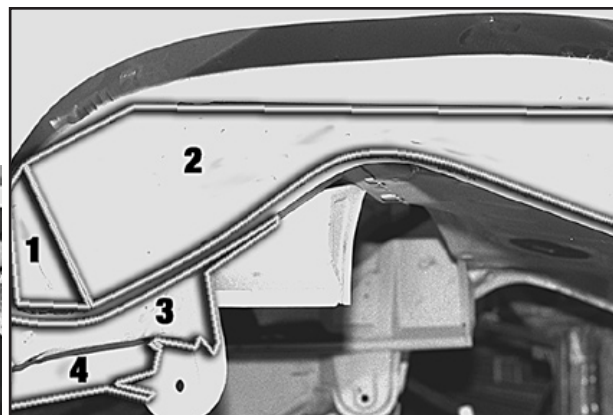

Outer Rocker Panel

Finally an excellent reproduction of the outer steel factory rocker panel. Identical to the original at a fraction of the new price.

Left Steel Rocker Panel

... [B914 503 125 10 \\$165.00](#)

Right Steel Rocker Panel

... [B914 503 126 10 \\$165.00](#)

Fiberglass Rocker Panel Set

... [RMIT 1431 \\$121.00](#)

Rocker Panel Installation Kit

... [B914 503 125 \\$13.20](#)

Flared GT-Style Rocker Panels

A perfect match to steel GT flares!

... [RMIT 1433 \\$210.00](#)



Fabulous ABS Rocker Panels - An Original Dealer Option

ABS rocker panels have raised Porsche® lettering and flared ends.

ABS Rocker Panel Set

... [RMIT 1432 \\$121.00](#)



914 GT Extra-Wide Rear Quarter Panels, Pair

These quarter panels are designed to take up to 12" wide rims. Light weight for racing. Average 4 lbs each.

Pair Quarter Panels ... [RGT 095 \\$478.50](#)

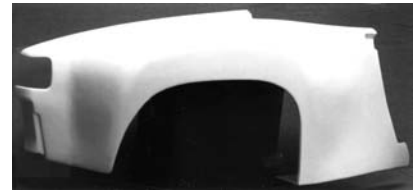

Quarter Panel Sail Replacement

Bubbling under the side vinyl is caused by body rot. Originally the only way to solve this was to replace the quarter panel! To make the job simple we made a patch panel. It is large enough to solve any rust problem in the area and welds in easily! See side vinyl kit on page 130.

Left Sail Panel ... [B914 503 943 10 \\$137.50](#)

Right Sail Panel ... [B914 503 944 10 \\$137.50](#)

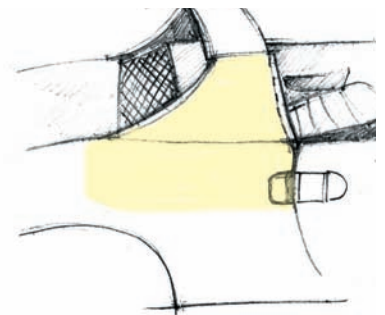

Wurth Trim Paint Satin Black

Details make a world of difference. This is best used on a part where flex is part of its job and is not intended to refinish non flexible steel parts.

Wurth Trim Paint Satin Black ... [RGR1013 \\$16.44](#)



Door Catch Reinforcement

Some early model 914s did not even have this necessary piece - what a safety concern! Replace or install one of these factory duplicates easily when replacing the door jamb or installing the great 9014 kit.

Door Jamb Replacement ... [B914 503 903DC \\$27.50](#)

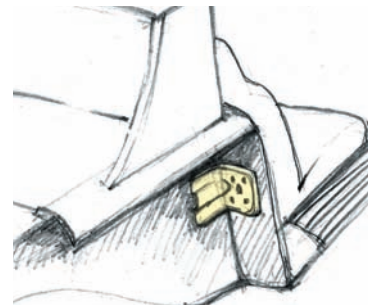

THE 914 BODY

Door Jamb Repair Panel

The door jamb repair completes the rusted quarter/sill panel repair. You will need this piece if you notice bubbling or rust-through near the door catch. This piece is more difficult to weld in, but makes a perfect undetectable repair. Remember to save the DOT sticker in the left door jamb!

- L. Door Jamb ... [B914 503 903 10 DJ \\$130.90](#)
- R. Door Jamb ... [B914 503 904 10 DJ \\$130.90](#)



916/914-6 GT Flares

The GT look is the rage these days! Our GT flares are exact duplicates of the real thing and give your car GT identity, as well as enabling 7" & 8" wheels to be installed! Easily installed by a competent body shop, you will love the look and the handling! Years in development, our own steel GT flares are perfect replicas at an incredible price. Designed and manufactured by Automobile Atlanta!

Repro Steel Flare Set

... [B914 503 908GT \\$995.00](#)

GT Fiberglass Flare Set ... [RMIT 1420 \\$550.00](#)

Factory Steel Flare Set

... [G914 503 908 GT \\$3,250.00](#)

AUTOMOBILE ATLANTA
PORSCHE EXPERTS

How to Build the Ultimate Rotisserie

By GEORGE A. HUSSEY, IV
-Dr. 914-

AUTOMOBILE ATLANTA
PORSCHE EQUIPMENT
808 SOUTH HARRISSETTA HIGHWAY
HARRISSETTA, GA 30052
YEAR-LINE (770) 427-2844

Copyright©1992 by George Hussey, IV
All rights reserved including the right of reproduction in whole
or in any part without permission from the publisher.



Rotisserie

Frustrated by having to weld in new panels upside down and developing back problems from it, we decided to make 914 restoration as easy as rotisserie cooking of a chicken. Simply sit or stand in one place and spin it around! Yes, this custom built rotisserie perfectly fits your 914 so that body restoration, display, and portability becomes easy! Super strong with heavy duty rollers, the rotisserie can be specially ordered in any Porsche color you desire!

Rotisserie ... [BRT 914 \\$1,045.00](#)

Rotisserie plans only

... [BTC 1025 \\$16.50](#)

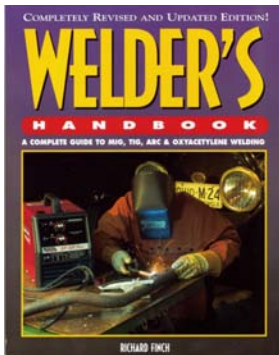

Welder's Handbook

By Richard Finch. A complete guide to MIG, TIG, Arc, and Oxyacetylene welding. The revised and updated classic handbook contains the latest information available. Welder's Handbook has sections on welding, brazing and cutting, equipment and safety, fitting and jiggling, gas welding, soldering, plasmas cutting and special welding. 8-1/2" X 10-7/8", 176 pgs.

Welder's Handbook ... [RHP1264 \\$19.58](#)

Sheet Metal Handbook

By Ron and Sue Fournier. Detailed information on how to form and shape sheet metal for competition, custom or restoration use. Chapters include hammer forming tools, terms and equipment, riveting techniques, layout, design, and pattern making-making. A super companion to the Metal Fabricator's Handbook. 8-1/2" X 10-7/8", 144 pgs.

Sheet Metal Handbook ... [RHP575 \\$19.58](#)

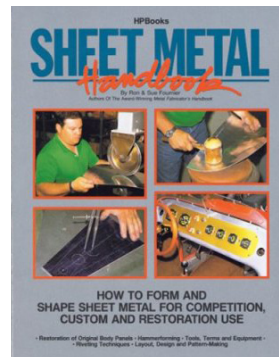

Metal Fabricator's Handbook

By Ron Fournier. How to build structurally sound, good-looking metal parts for custom street rods, race cars or restorations. Over 350 step-by-step photos and instructions illustrate proper welding, metal shaping, and design techniques. 8-1/2" X 10-7/8", 176 pgs.

Metal Fabricator's Handbook ... [RHP709 \\$19.74](#)

Wurth Zinc Spray Paint

98% pure zinc. This is the ultimate muffler, heat exchanger, and intake runner paint that matches the factory color, and is resistant to heat, sand, and water. Also perfect for sealing welded seams in restoration projects. Dries in 15 minutes.

Wurth Zinc Spray ... RGR 1012 ... \$26.00



The 914-G GT Look

The rage these days is to make a 914-6 GT Replica. Now we have assembled all of the parts for a complete do-it-yourself kit!

- a. 964 Aero Mirror Kit, p. 117
- b. Rollbar, p. 99
- c. Fiberglass Decklids, p. 95
- d. Hood Pin Kit, p. 95
- e. Euro Turn Signal Kit, p. 144



- h. GT Flared Rocker Panels, p. 89
- i. Momo Wheel, p. 56
- j. GT Sport Seat, p. 104
- k. Sparco Seat Belt, p. 126
- l. Pilot Driving Lights, p. 141

- f. GT Flares, p. 90
- g. Kinesis Wheels, p. 68

- m. Euro License Plate Bracket, p. 152

THE 914 BODY



Fiberglass Bumper Replacements

Our front and rear stock fiberglass bumpers incorporate both the face bar and rubber top seal into one piece, facilitating installation and saving hundreds over the originals. Please keep in mind that fiberglass does not provide the crash protection of steel, but saves weight for autocross and track events!

Front Fiberglass Bumper

... [RMIT 1409 \\$275.00](#)

Rear Fiberglass Bumper

... [RMIT 1410 \\$275.00](#)

One-Piece GT Fiberglass Bumper with Oil Cooler Cutout

A perfect match to the oil cooler valance for the ultimate track cooling and factory 914-6 GT Identity. This high quality part is an exact duplicate of the factory piece and very light for racing applications.

GT Bumper ... [B914 505 901 \\$269.50](#)



916 Front/Rear Bumper

Achieve the great look of the rare 916 prototype for your 914. Fiberglass bolt-on will also reduce weight. Primed and ready for painting to match your 914. The smooth clean appearance is also aerodynamically efficient! (For stock fenders. Bumper must be slightly modified to fit GT flares.)

916 Front Bumper ... [RMIT 1407 \\$258.50](#)

916 Rear Bumper ... [RMIT 1408 \\$269.50](#)

IMSA Front Airdam/Bumper

This IMSA front airdam/bumper gives your 914 a radical aerodynamic look and enables you to mount an auxiliary oil cooler and high-powered driving lights. When painted the car's color, it elongates the front end for the slope nose appearance!

IMSA Front Bumper ... [RMIT 1402 \\$288.75](#)



Front and Rear Bumper Top Seal Kit

For 1970-74.

... [R914 503 023 10 \\$425.00](#)

... [R914 503 027 10 \\$375.00](#)

Buy Both and Save! \$750.00/set



Forever Black

Forever Black is a product that will permanently dye all faded plastics and rubber. A quick cleaning (cleaner provided) and an easy application of Forever Black will make your rubber spoilers, bumper guards, tires and black plastic or rubber items get their black back. From then on paste, shoe polish, and a brush will do the rest!

Forever Black ... [RGR 5013 \\$14.25](#)

Special Edition Spoiler

Made from our own precise molds, this spoiler, our most popular, replicates the expensive factory part at a fraction of the cost! Install one today for a tasteful factory look.

Limited Edition ... [B914 503 235 10 \\$125.00](#)

Factory Limited Edition Spoiler

... [G914 503 235 10 \\$698.00](#)

Economy Version (not our mold!)

... [RMIT 1406 \\$99.50](#)



Front Spoiler with Brake Ducts

Great for aerodynamics, and additional brake cooling for you racers! This spoiler can be painted to match the car for a much lower appearing 914.

Spoiler w/Brake Ducts

... [RMIT 1401 \\$105.00](#)

Snowplow Front Spoiler

With a dramatically racy look and aerodynamic efficiency, this spoiler reduces lift at high speed for better traction. Great for you racers or racy for you street people.

Front Spoiler ... [RMIT 1404 \\$105.00](#)



Ultimate Air Dam

Improve front aerodynamic downforce for quicker lap times with the ultimate air dam. Sturdy, hand-laid fiberglass dam is about 1 inch deeper than the 911639 air dam and features a center that can be trimmed for an oil cooler duct opening. Choose with or without brake duct openings.

Airdam With Brake Holes ... [RAR 185 473 \\$218.90](#)

Airdam Without Brake Holes ... [RAR185474 \\$218.90](#)

THE 914 BODY



Flexdam Front Spoiler

Dramatically low to eliminate lift. This spoiler is necessary equipment for high speed track use.

Flexdam ... [RMIT FD 1014 \\$152.08](#)

GT Front Valance

Available for flared or stock fender wells, this is an exact duplicate of the NLA factory part. Stock GT appearance with cutout for the oil cooler.

Front Valance for Stock Fenders ...
B914 501 905 0A \$192.45

Front Valance for Flared Fenders ...
B914 501 905 00 \$192.45

Stock Replacement Valance

B914 503 121 10 \$104.00



Front Spoiler Without Brake Ducts

Same appearance as above but without the cooling ducts. For you street people. This spoiler can be painted to match the car for a much lower appearing 914.

Spoiler w/o Brake Ducts
... [RMIT 1403 \\$89.76](#)

Front Valance Installation Kit

... [B914 503 121 \\$9.35](#)



Rear Valance With No Notch

Special valance without notch for custom applications. Monza exhaust will tuck up nicely under this one!

Valance No Notch (For Monza System)
... [RMIT 1413 \\$103.95](#)





Rear Valance For 914 With or Without Notch

Replica of factory equipment on all late 1972-76 914s but at a fraction of the cost of the original. Replace your missing one today!

Rear Valance w/Notch ... [RMIT 1411 \\$92.40](#)

Rear Valance w/Hole ... [RMIT 1412 \\$103.95](#)

Rear Valance, No Notch, No Hole (for Monza Dual-Tip Mufflers)

... [RMIT 1413 \\$103.95](#)



Rear GT Valance

Something the factory never produced so we did. Nicely finishes any flared 914. Comes without notch for stock or custom applications.

Rear GT Valance ... [B914 503 009 10 \\$197.95](#)

Rear Valance Installation Kit

Perfect to reinstall the factory or aftermarket fiberglass valance to your 914. We personally assemble this complete kit from factory nuts bolts and screws as well as custom made no longer available from the factory rubber spacers. Perfect for the fussy concours enthusiast

Rear Valance Installation Kit ... [B914 503 009 \\$9.35](#)



Worth Trim Paint Satin Black

Details make a world of difference This is best used on a part where flex is part of its job and is not intended to refinish non flexible steel parts.

... [RGR1013 \\$16.44](#)

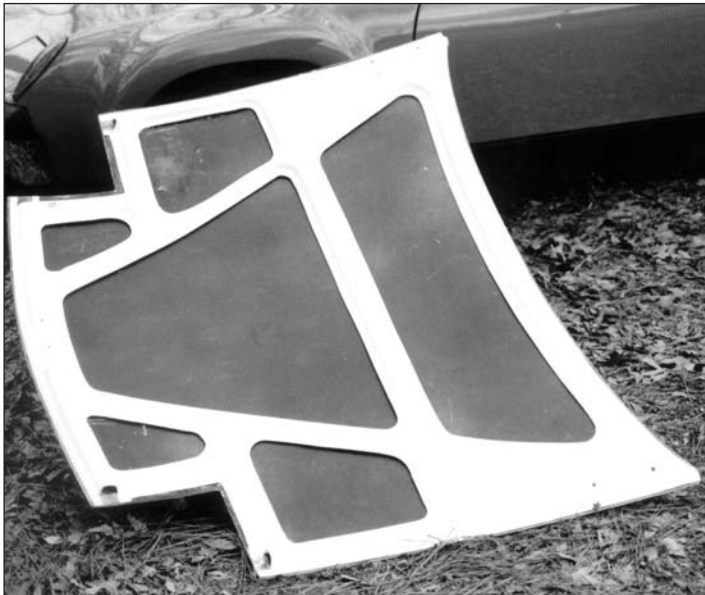

Reproduction Fiberglass Hood

We manufacture this excellent reproduction of the 914-6 GT fiberglass hood! Its lightweight design is a must for the serious racer. When painted it is hard to distinguish from the factory GT variety.

GT Hood ... [B914 511 903 00 \\$575.00](#)

Hood Pin Kit for the Factory GT Look ... [B914 511 903 00 A \\$54.95](#)

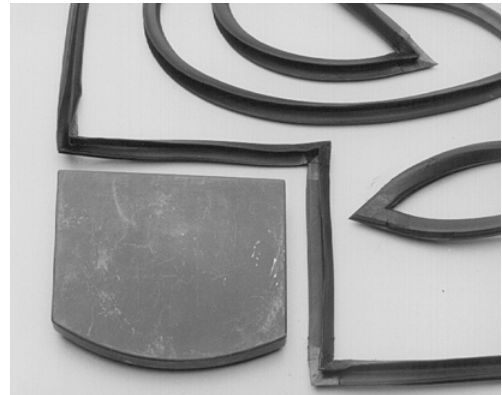

Front Hood Seal

... [B914 511 901 10 \\$59.50](#)

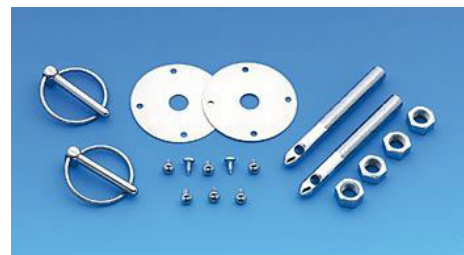

THE 914 BODY

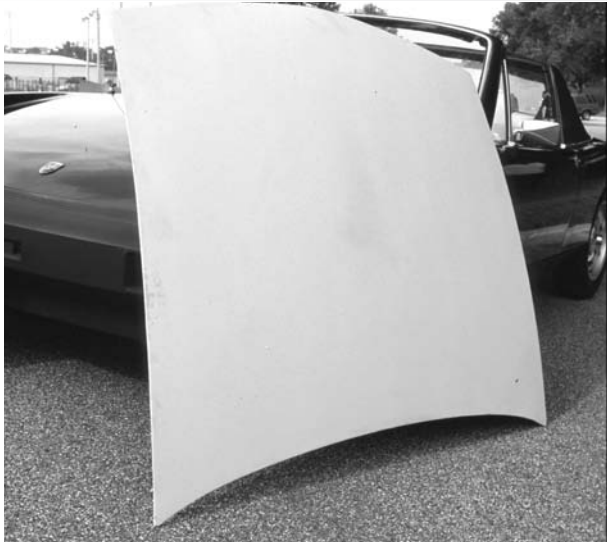

Fiberglass Hood Without Lights

For you serious racers, we offer the one-piece fiberglass hood to cover the headlight boxes. Great for racing where headlights are not required or for the 9014 racers concerned with weight savings.

One-Piece Fiberglass Hood ... [B914 511 001 OP \\$495.00](#)

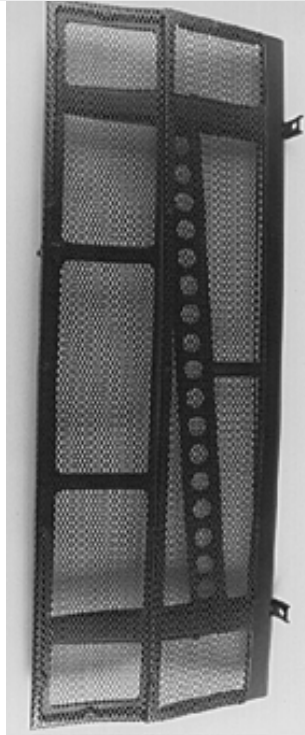

916 Double GT Grille Engine Lid

This lid gives you twice the cooling. We duplicated an exact 916 engine lid with the double grille just for you! Twice the air flow and a must for track cars. Paint to match or leave black like the original! Part sold rough. Core charge \$100.00.

916 Double GT Grilled Engine Lid
... [B914 501 909 00 \\$412.50](#)



Engine Grille To Lid Welding

Beautiful reproduction! Perfect replacement for the long discontinued factory part, this fits in between the engine lid grill and the painted part of the engine lid acting as a buffer. Easily installed, we include enough for the two auxiliary grilles as well.

Engine Grille to Lid Welding
... [B914 504 105 10 \\$13.20](#)

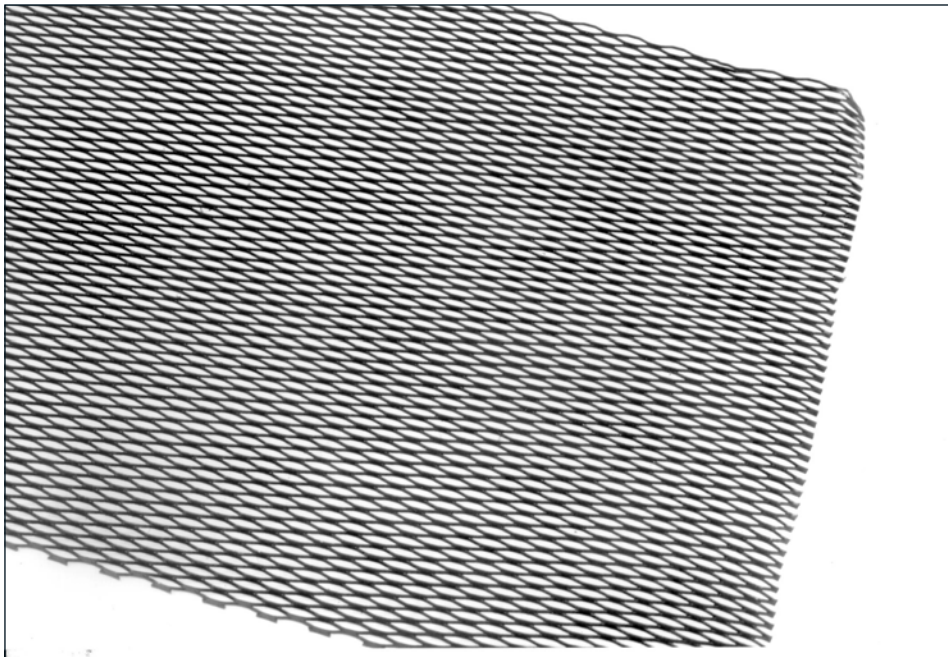

GT Rear Grille Material to Make Your Own

We receive hundreds of calls a year for the original GT 916 engine grille, so we found the original German chicken wire to do it yourself!

GT Grille Material ... [B914 504 013 00 \\$55.00](#)



Edging For Sheet Metal Front Engine Cover

This is the black protective edging that fits on the edge of the engine sheet metal. It finishes the raw edge to prevent cuts.

Engine Cover Edging
... [B914 504 111 10 \\$16.17](#)

ENGINE LID DRIP PAN

Finally! A quality reproduction engine lid drip pan to replace the long discontinued factory part. This late style reproduction fits all 1970-76 914-4 models and protects the fuel injection from water damage.

Engine Lid Drip Pan ... [B914 512 189 10 \\$125.00](#)

Engine Lid Drip Pan Hardware Kit

Impossible to find anywhere, we were finally to put a nice kit together to mount the new style drip pan to your 914 lid.

Drip Pan Hardware Kit ... [B914 512 022 00 \\$10.45](#)

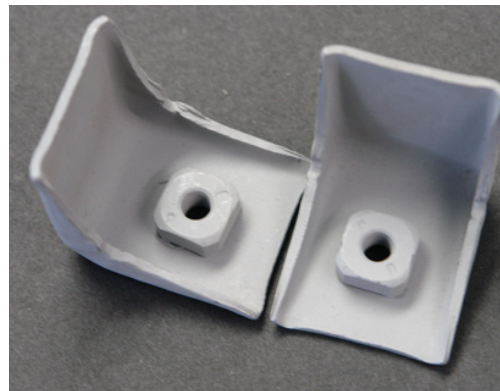
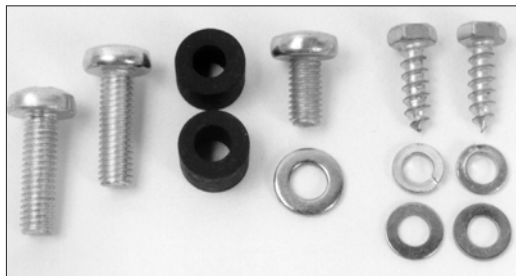

Engine Lid Hinge Bracket

Does your engine lid hit the rear deck even after adjustment? The *Engine Lid Hinge Bracket* is broken! Never offered as a separate piece from the factory, it is now available! Easily welded on it, makes a perfect repair.

Engine Lid Hinge Bracket ... [B914 502 011 10A \\$28.05](#)



Latch Cup, Door Vent and Drain Funnel

Three parts that impress the concours judges! Broken drain funnels spill acid rain on your engine, your top latch cups turn yellow and the door jamb vents always get over sprayed. Why not clean up your 914's appearance with new ones?

1. Drain Funnel ... [G914 559 231 10 \\$25.20](#)
2. Door Jamb Vent ... [G914 555 043 10 \\$51.66](#)
3. Top Latch Cup ... [G914 559 227 10 \\$19.80](#)

Engine Grille Lettering

Plastic chrome "Porsche" lettering kit is a duplicate of the original chrome plastic letters installed on the engine grille of all 74-76 914 models. The kit includes seven plastic chrome letters, fourteen clips, and a lettering grid for placement. Easily installed, but remember not to tighten the nuts too much or the lettering peg will break!

Engine Grille Lettering ... [BPNA559 901 00 \\$65.00](#)



Clips

Large clips for engine grille. Original style, rubber covered. 12 required.

Engine Grille Clips ... [G999 507 220 40 \\$2.16/each](#)



G = Genuine • R = Aftermarket / Replacement •
U = Used • B = Rebuilt or Reproduction

THE 914 BODY



GT Rear Deck Lid

This lid lightens the load for decreased track times and gives your 914 a GT identity. This lid is not for street cars!

GT Rear Deck Lid ... [B914 512 901 00 \\$575.00](#)



Top Holders

This is the rubber holder in the extreme rear of the trunk that holds the hardtop in place. Critical to keep the top from rubbing the lid and scratching. Available in driver and passenger sides.

Front Top Holder, ... [G914 559 219 10 \\$16.92](#)

Rear Top Holder, R ... [G914 559 016 10 \\$22.94](#)

Rear Top Holder, L ... [G914 559 015 10 \\$22.94](#)



Rear Trunk Lid Latch

Beautiful cad plating!

Rear Trunk Lid Latch ... [B914 512 041 10 \\$55.27](#)

Extra Strength Nylon Trunk Lock Cam

If your trunk acts locked, the trunk lock cam is broken! We manufacture this part and guarantee it for life!

Trunk Lock Cam
... [G914 511 052 00 \\$13.20](#)

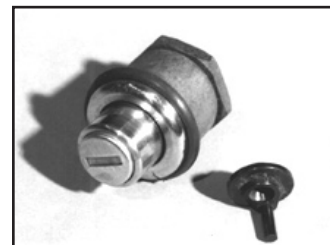

Reduce Drag Over 100 APh With Our GT-Type Rear Spoiler

Give your 914 the sporting GT look and reduce lift at high speeds with our rear spoiler. It is easily installed and should be painted to match the car. This part is a "must" for serious racers.

Rear GT Spoiler ... [RMIT 1415 \\$203.50](#)

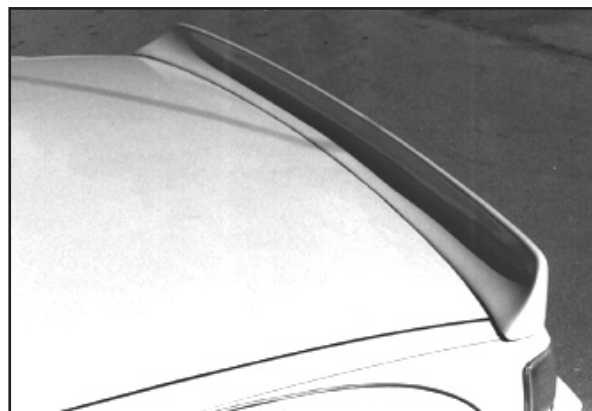

G = Genuine • R = Aftermarket / Replacement •
U = Used • B = Rebuilt or Reproduction

Pedestal Spoiler

The pedestal spoiler adds an updated look to your customized 914 while providing increased rear end stability. Add a wild look to your 914 with this highly functional pedestal spoiler.

Pedestal Spoiler ... [RMIT 1417 \\$202.13](#)

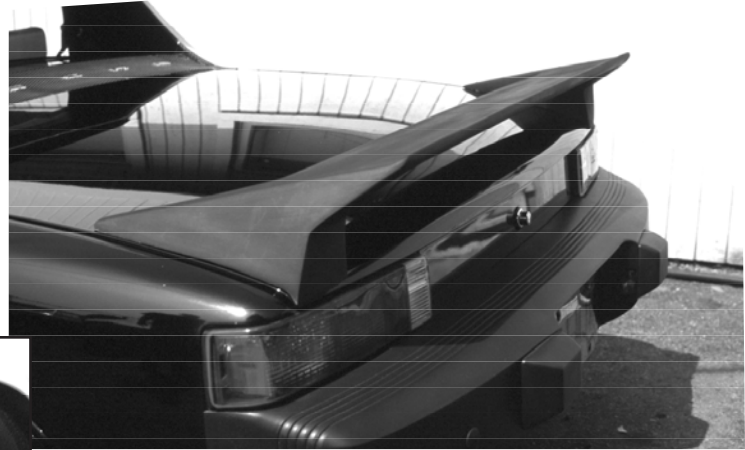

Wild Turbo Tail Spoiler

What a radical way to decorate your 914! (It does however reduce lift at high speeds!) This spoiler, made of black fiberglass, is easily paintable or you may install it "as is."

Rear Turbo Tail ... [RMIT 1429 \\$175.00](#)

Rear Trunk Lock Seal

No longer available from the factory, Automobile Atlanta remade this much-needed seal. Great reproduction for concours restorations and just a replacement as these seals always seem to suffer from overspray.

Rear Trunk Lock Seal ... [B914 512 193 10 \\$8.80](#)



914 Rollbar

Fabulous addition for stiffening and necessary equipment for any racing 914, this rollbar is easily installed by a competent welder. (\$60 shipping charge.) Open hoop is maintains original interior; V-Brace will require interior modification.

Rollbar Open Hoop ... [RP2 \\$999.00](#)

Rollbar V-Brace ... [RSEP2V \\$1,129.00](#)

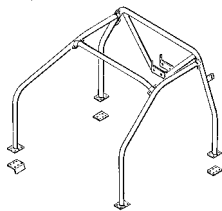
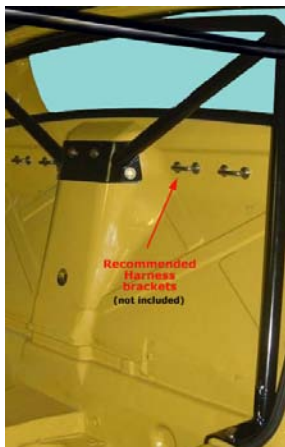

THE 914 BODY

Door Latch Seals

- Large Door Latch Seal ... [B914 531 601 10 \\$4.50](#)
 Small Door Latch Seal ... [B914 531 603 10 \\$4.50](#)



Interior Door Latch

For over 19 years this part never failed, but now they are all failing. How embarrassing when you have to roll down the window to open your door! Replace with a shiny, new one and open your door for another 15 years!

- Left ... [G411 837 071 \\$198.88](#)
 Right ... [G411 837 072 \\$198.88](#)

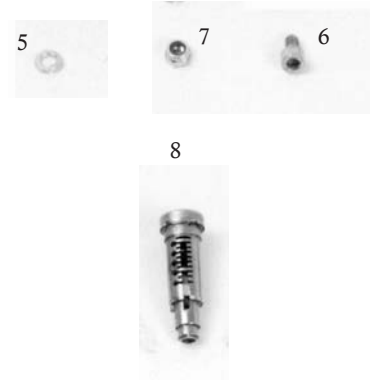
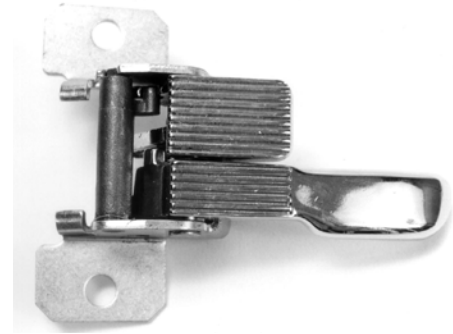

Door Latch Parts

We became very tired of the expensive factory door latch assembly so we had the individual parts made. Now you can replace just what's broken and not suffer from sticker shock.

- | | |
|--|--|
| 1. Door Latch Rivet Bolt (inc. in flap/base)... B914 531 905D \$7.15 | 5. Washer ... GN 011 5247 \$1.00 |
| 2. Door Latch Cam ... B914 531 905C \$13.20 | 6. Inner Door Late Allen Bolt ... R900 067 006 02 \$1.10 |
| 3. Door Latch Base ... B914 531 905B \$49.50 | 7. Nyloc Nut ... GN0 211 931 \$2.00 |
| 4. Door Latch Flap (Left or Right) ... B914 531 905/906 00 \$99.00 | 8. Used Lock Cylinder ... U914 347 903 00 \$35.00 |

Extra Door & Ignition Keys

Extra keys are a must for every 914 owner! The black operates all locks while the red operates the ignition and doors only. The Keylight is handy to find the locks! Keep several sets of keys around! They're great looking!

- Red Key Blank ... [R914 531 903 11 \\$16.88](#)
 Black Key Blank ... [G914 531 903 10 \\$22.48](#)
 Black Blank without "Porsche" ... [G914 531 903 10 \\$8.50](#)
 Lighted Key Cap ... [G944 538 041 00 \\$26.78](#)
 Key Shaft For Lighted Key ... [G911 538 903 00 \\$25.75](#)



Door Strap

This part always wears and either does not hold the door open and/or finally breaks allowing the door to open too far and bend! Don't take a chance, replace yours now! \$75.00 Core Charge.

- Door Strap ... [B914 531 037 10 \\$98.94](#)
 Strap Roller Kit ... [RPP912 227 \\$30.00](#)
 Replacement Spring ... [B914 424 545 00 \\$9.50](#)



Window Regulator Button

Wonder why your 1970-72 side window suddenly comes crashing down? The window regulator button is worn and has come loose from the regulator lifting pin. Secure it now with a fresh new regulator button. Never available by itself, our friend at the 914 Owners Association took it upon himself to solve the problem with this high quality part.

- Window Regulator Button ... [B914WRB \\$14.30](#)

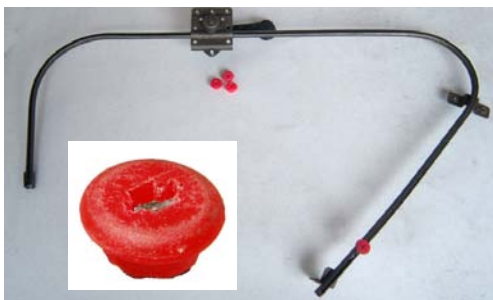



Window Cranks

Three styles for different models.

1. 1970-early 73 Chrome Base ... [G111 837 581D \\$43.94](#)
2. 1973.5-74 "Skinny" Handled ... [R113 837 581J \\$9.24](#)
3. 1975-76 "Fat" Handled ... [R321 837 581 \\$9.24](#)

Squeegee, End Caps, Outer Fuzzy Strips, and Squeegee Gutters

All necessary when replacing the door guts, and critical for proper window adjustment and smooth operation.

1. 1970-early 73 gutter L or R ... [G914 531 951 10 \\$75.00](#)
Left 73.5-76 gutter ... [G914 531 959 10 \\$75.00](#)
Right 73.5-76 gutter ... [G914 531 958 10 \\$75.00](#)
2. Left Squeegee ... [R914 531 873 10 \\$7.50](#)
3. Right Squeegee ... [R914 531 874 10 \\$7.50](#)
4. Left 70-early 73 Rear Window Cap ... [B914 542 111 10 \\$29.50](#)
Right 70-early 73 Rear Window Cap ... [B914 542 112 10 \\$29.50](#)
5. Left 73-76 Rear Window Cap ... [B914 542 173 10 \\$23.50](#)
Right 73-76 Rear Window Cap ... [B914 542 174 10 \\$23.50](#)



GT Door Pull Straps

Beautiful and identical to the factory original door pull straps. These were installed on all of the factory 914-6 GT models in place of the heavier door box armrest assemblies. Add the factory GT look to your 914.

Door Pull Straps, Set of Two
... [B901 531 067 00 \\$32.95](#)

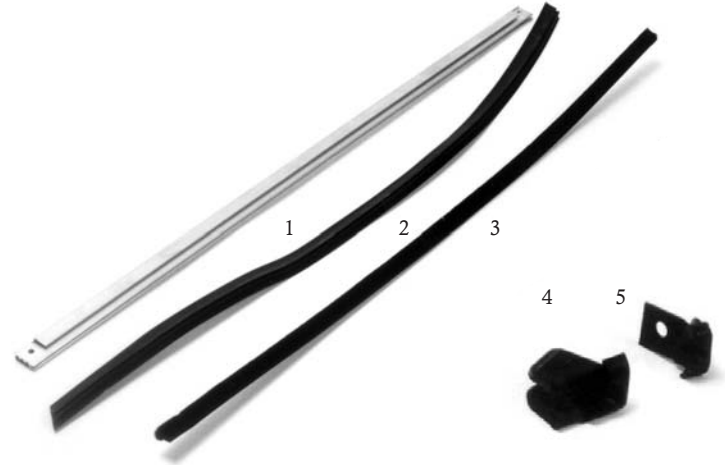

Weatherstrip Adhesive

This handy tube glues everything from weatherstrips to the mirror patch! A must for the tool box, we use this adhesive in our shop everyday.

Weatherstrip Adhesive ... [RGR 1001 \\$15.40](#)



Windshield Top Seal, Topside Seal and Vertical Rollbar Seal Kit

Everyone hates the chronic water leaks. Solve them today with careful filament of these new seals.

- Left Vertical Rollbar Seal ... [B914 531 821 10 \\$38.50](#)
- Right Vertical Rollbar Seal ... [B914 531 822 10 \\$38.50](#)
- Windshield Topseal ... [G914 563 039 10 \\$375.00](#)
- Left Topside Seal ... [B914 531 185 10 \\$38.50](#)
- Right Topside Seal ... [B914 531 186 10 \\$38.50](#)
- Windshield Top Seal ... [B914 563 039 10 \\$199.50](#)

**FREE T-SHIRT
OFFER**
...on Page
231!



THE 914 BODY



Front Windshield and Rear Window Installation Kits

The ultimate kits for 914 glass installation. Everything you need to insure a perfect factory installation of your 914 windshield, or rear window chrome and mirror in one kit, plus the most important thing, precise instructions!

1. Front Windshield Installation Kit ... [BAA 541 \\$42.35](#)
2. Rear Window Installation Kit ... [BAA 542 \\$19.25](#)

Dash To Windshield Bead

The best time to replace this part is when you are replacing the windshield. Easily installed, it is a compliment to any upper dash. Genuine has metal in it and squeezes onto the channel. Repro glues onto the channel.

- Genuine Dash to W/S Bead ... [G914 552 263 10 \\$107.78](#)
 Repro Dash to W/S Bead ... [B914 552 263 10 \\$39.50](#)

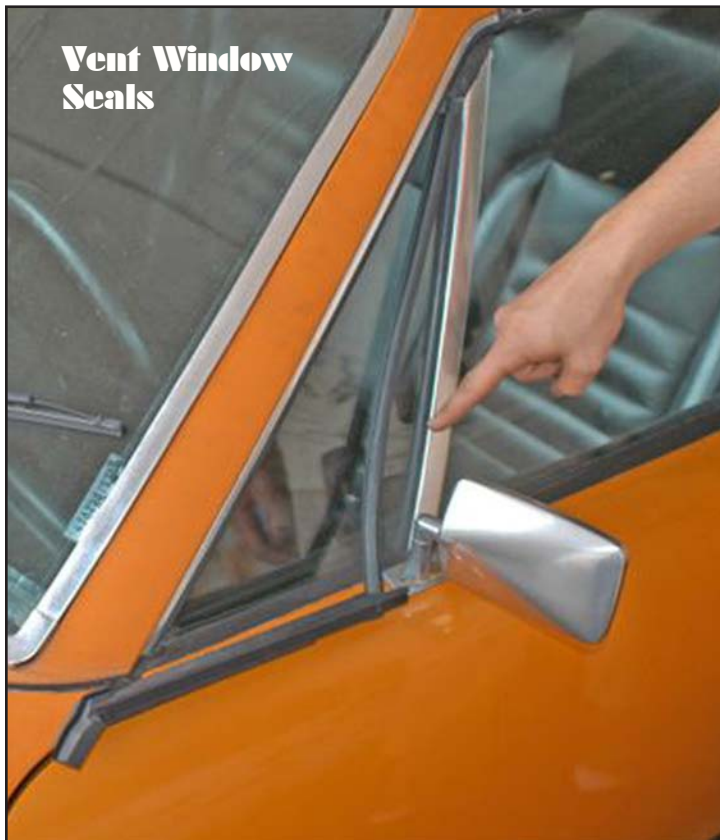

- Vent Window Seal, Left ... [B914 542 325 10 \\$119.39](#)
 Vent Window Seal, Right ... [B914 542 326 10 \\$119.39](#)



Tinted Windshield

Brand new tinted windshield for all 914 models. Easily installed by the home hobbyist following the Dr. 914 windshield installation procedure included in our BAA541 windshield installation kit (available separately).

- Windshield, Tinted ... [R914 541 1011 0 \\$295.00](#)

Windshield Chrome Pieces

Windshield Chrome Piece, Left

... [G914 541 213 10 \\$83.84](#)

Windshield Chrome Piece, Right

... [G914 541 214 10 \\$85.86](#)

Windshield Chrome Piece, Center, Lower

... [G914 541 215 10 \\$77.96](#)

Windshield Chrome Clip, Center

... [G914 541 219 10 \\$11.92](#)

Windshield Chrome Trim Clip, 19 Req'd

... [G914 541 921 11 \\$1.54](#)

Windshield Chrome Corner Connector, 2 Req'd

... [G914 541 217 10 \\$11.62](#)



Reupholstered Seats

Beautifully reupholstered seat in black for the "Don't Do It Yourself!"

1970 Black Pebble Weave

... [U914 521 010 09 RB \\$599.50/each](#)

1971 Black Smooth

... [U914 521 010 10 RB \\$599.50/each](#)

1972-1974 Brick Weave

... [U914 521 010 12 RB \\$599.50/each](#)

1975-76 Basket Weave

... [U914 521 010 15 RB \\$599.50/each](#)



914 Appearance Group Console

Our 914 appearance group console is a work of art! An exact duplicate of the factory console, it is made of thicker wood and cut for the optional VDO gauges. All you will need is our console heater switch to complete the job. This console will give your 914 a plush, sophisticated look as well gauge what your 914 is doing! Specify whether factory instruments or blank face or VDO gauges. Gauges not included, of course!

Center Console ... [B914 559 402 10 RP \\$236.50](#)

Center Console ... [B914 559 402 10 AC \(for Air Conditioned 914\) \\$236.50](#)

Repro Seat Loop



Made of nylon II and guaranteed for the life of your vehicle.

Repro Seat Loop ... [B914 521 029 10 \\$18.50](#)



Factory Seat Loop

For Concours buffs when nothing else will do, replace the broken loop with this shiny factory original.

Seat Loop ... [G914 521 029 10 \\$95.00](#)

THE 914 BODY

914 Sport Seat

Out of the vintage 914 parts cellar comes the 914 Sport Seat. This seat, built on the stock factory shell, is super comfortable and gives the extra support never found in its production line counterpart. The high bolster factory seat is a direct bolt-in, not a sloppy retrofit, and is covered with perfect match factory material. Why didn't the factory make these seats? Core charge \$50.00.

914 Sport Seat ... [BAA521 383 00 \\$522.50](#)



Corbeau 914 Seat

The Classic Bucket is the perfect "vintage/classic style" bucket seat for your Porsche 914. It is ideal for these classic cars, and even kit-car applications such as the Porsche 9014 project. Standard features include: tubular steel frame, injection molded foam, an adjustable headrest and custom vertical stitching along the center of the seat. The Classic Bucket will fit up to a 36" waist. Available only in black. Leather is an option. Each seat comes with seat rails.

Corbeau Seat, each ... [RCB 312 85 \\$315.95](#)

914-6 GT Seat, Repro Factory

Perfect duplicate of the original GT sport seat fitted to the racing 914-6 models. Accomplish historical accuracy and concours look with these great seats.

914-6 GT Factory Seat, Repro ... [B914 521 303 71 \\$695.00](#)



Automobile Atlanta's 914 Seat Upholstery Kits of Original Material

We make these excellent seat reupholstery kits from the original material and use them in our restoration shop. Each 914 seat consists of three parts: the cushion, the backrest and the bolster back (the smooth part). You will need all three to completely recover your seat! Available in black, brown, tan or white.

**AVAILABLE
IN BLACK/
BROWN/TAN/
WHITE**

	Cushion	Backrest	Bolster
1970 Left	B914 521 035 09	B914 555 010 09A	B914 555 010 09B
1970 Right	B914 521 075 09	B914 555 081 09A	B914 555 081 09B
1971 Left	B914 521 035 10	B914 555 010 10A	B914 555 010 10B
1971 Right	B914 521 075 10	B914 555 081 10A	B914 555 081 10B
1972-74 Left	B914 521 035 12	B914 521 010 12A	B914 521 010 12B
1972-74 Right	B914 521 035 12	B914 521 061 12A	B914 521 061 12B
1975-76 Left	B914 521 035 14	B914 521 010 14A	B914 521 010 12B
1975-76 Right	B914 521 035 14	B914 521 061 14A	B914 521 061 12B
	Cushion \$82.50	Backrest \$82.50	Bolster \$82.50

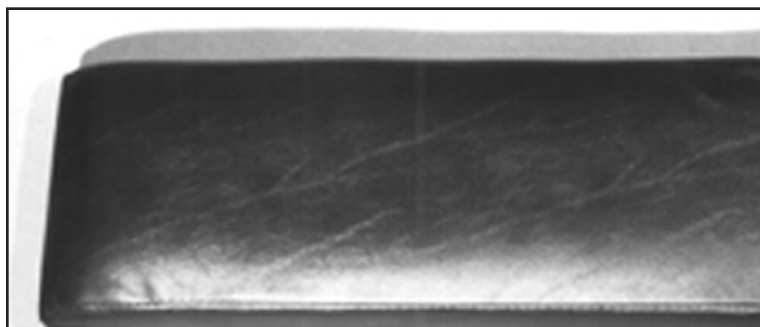

Recovering Kit For Deposit Box Top

Recover your factory 1973-76 console box top with our handy recovering kit. Easily installed by the amateur, our cushion cover has the original map pocket. Kit is available in black only.

Recovering Kit ... [B914 521 556 00 \\$43.45](#)



Vinylex Vinyl Cleaner

1/2 Liter. Vinylex will keep your vinyl looking new. Vinylex cleans, conditions, protects, and renews vinyl, rubber, and plastic without leaving that freshly-greased look. It protects against fading, cracking, and drying caused by age, environmental pollution and ultraviolet rays. Great 1/2 liter size with sprayer top.

Vinylex Vinyl Cleaner ... [RGR5003 \\$13.14](#)

Interior Plugs and Cup Washers

1. Small (Bolsters) ... [G914 552 233 10 \\$3.60](#)
2. Large (Door Pocket & Lower Dash) ... [G914 555 129 10 \\$4.50](#)
3. Cup Washer for Door Pocket Trim Screws ... [R999 591 011 12 \\$3.30](#)

914 Center Cushion

Seat three with our center seat cushion! An exact duplicate of the \$187 factory unit, our cushion fits perfectly in the plastic center tray and exactly matches your interior. Beware of cheap imitations!

Center Seat Cushion ... [B914 521 053 09 \\$43.45](#)
Factory Cushion (specify color)
... [G914 521 053 09 \\$226.88](#)

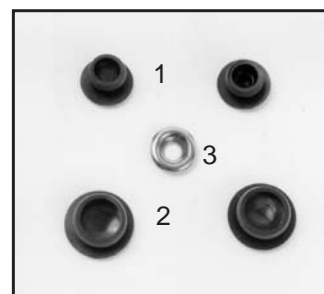

THE 914 BODY



Custom Carpet Kits For A New Interior Look

SHOP-FITTED CUSTOM CARPET KITS FOR A NEW INTERIOR LOOK! Our custom carpet kits are better because the material resembles the original and we have fit them in our restoration shop! The loop kit will brighten your interior and complete your restoration, while the plush will update your 914 to the later 911 look. The kits have 10 pieces and completely carpet the interior. We also have limited supply on new factory carpet kits. Please call.

'70-'71 German Charcoal Loop Kit

... [B914 551 077 10 A \\$324.50](#)

'70-'71 Charcoal Loop Kit ... [B914 551 077 10 700 \\$214.50](#)

'72-'76 German Charcoal Loop Kit

... [B914 551 077 12 A \\$302.50](#)

'72-'76 Charcoal Felt Kit ... [B914 551 000 12 700 \\$214.50](#)

'72-'76 Charcoal Loop Kit ... [B914 551 077 12 700 \\$214.50](#)

'72-'76 Brown Felt Kit ... [B914 551 000 12 400 \\$214.50](#)

'70-'71 Black Plush Kit ... [B914 551 023 10 700 \\$199.95](#)

'72-'76 Black Plush Kit ... [B914 551 023 12 700 \\$199.95](#)

'70-'71 German Brown Loop Kit ... [B914 551 077 10 400 \\$302.50](#)

'72-'74 German Brown Loop Kit ... [B914 551 077 12 400 \\$302.50](#)

'70-'Dec.'71 German Brown Plush Kit

... [B914 551 023 10 400 \\$302.50](#)

'72-'74 Brown Plush Kit ... [B914 551 023 12 400 \\$192.50](#)

'70-'71 Tan Plush Kit ... [B914 551 023 10 500 \\$192.50](#)

'72-'74 Tan Plush Kit ... [B914 551 023 12 500 \\$192.50](#)

'70-'71 German Tan Loop Kit ... [B914 551 077 10 500 \\$324.50](#)

'72-'76 German Tan Loop Kit ... [B914 551 077 10 500 \\$324.50](#)

'75-'76 Wheat Plush Kit ... [B914 551 023 14 500 \\$192.50](#)





COOL SEAT SAVERS

The seat savers save your seats! They also keep them cool in the summer. Custom fit with the bold logo, they also cover unsightly cracks and tears! Specify black, brown, or tan.

Seat Savers

... [RSS 5005 Set \\$105.88](#)

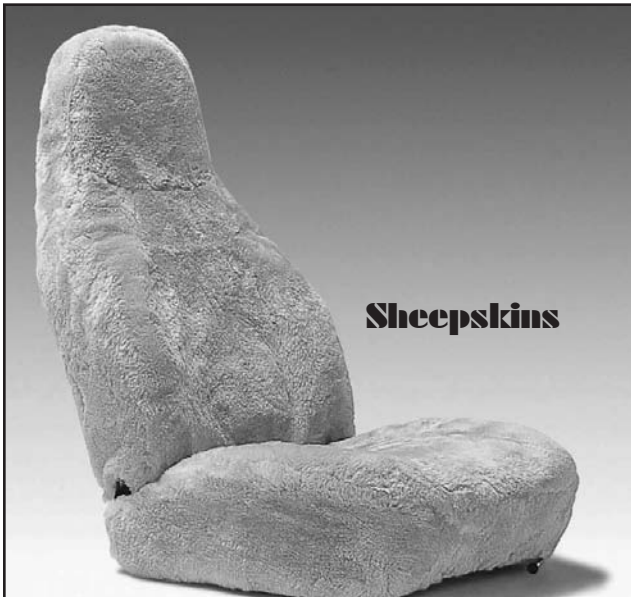

Sheepskins

BEWARE OF CHEAP IMITATIONS! Our sheepskins have the sheep on both sides, not like imitations with cloth on the inside! Each is custom-made for your 914 seat and is therefore a perfect fit! They will keep you warm in the winter and cool in the summer! Sold as a set of two.

Black Sheepskins ... [RSS 6006 01 \\$605.00/pair](#)

Honey Sheepskins ... [RSS 6006 03 \\$605.00/pair](#)

CD Catalog

CD of all of our print catalogs: 356, 911, 912, 914, 924, 944, 928, 968, and Boxster. The technical side of the CD contains many technical articles and pamphlets written by Dr. 914. Prices may not be accurate on some of the older catalogs; call, email, or check online for current price. 30-minute Porsche related video and tour of 914 World Headquarters, Automobile Atlanta.

CD Catalog ... [BCDCAT1 \\$1.00](#)

**30-MINUTE
914 VIDEO!**



Crested Key Fob

In red, yellow, green, black, brown - specify color.

Crested Key Fob ... [GWAP05009216 \\$21.60](#)

THE 914 BODY



Speaker Grille Set, Left And Right

These custom made speaker enclosures are different from the originals, but fit beautifully and perfectly. Custom made for Auto Atlanta, each enclosure is sure to bring a finishing touch to your Porsche. Order custom fit Blaupunkt speakers on page 150.

Speaker Grille Set ... [B914 551 505 10 \\$148.50](#)

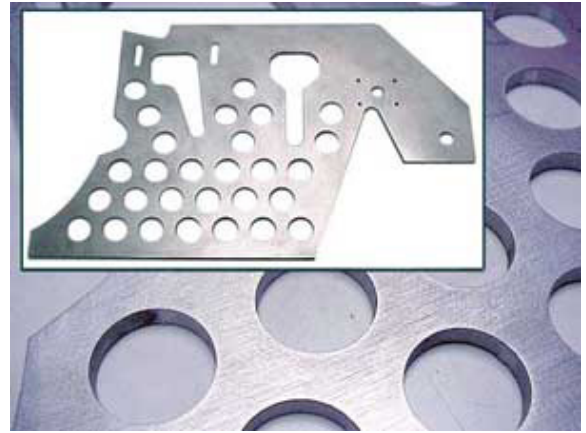

Laser Cut Aluminum Pedal Board

The original wooden board could warp dry and crack, resulting in its premature replacement. The aluminum floorboard is forever! In addition, your foot can break the original board with accidental pedal miss. The top of the wooden board is fitted with rubber clutch bushings, which are broken or cracked in most of the boards, due to the clutch pedal pressure. If not corrected, your pedal will travel way too far, wearing out your cable and components. Our board's perforation will allow easy examination of the pedal cluster and the brake cylinder for leaks.

Brushed Aluminum Pedal Board ... [RMB 242 88 \\$110.95](#)

Black Aluminum Pedal Board ... [RL F06BP \\$121.00](#)



Auto Atlanta Pedal Board

By now, all of our pedal boards have deteriorated. There is nothing like a fresh one to provide a much firmer feel to the pedals as well as to the whole car! Adjust the clutch pedal stop while you're at it. Hardware is not included.

Reproduction Pedal Board ... [B914 551 061 10 \\$47.30](#)

Black Carpet Strip ... [G914 551 137 11 \\$45.62](#)

Black Threshold ... [G914 551 419 11 \\$68.97](#)

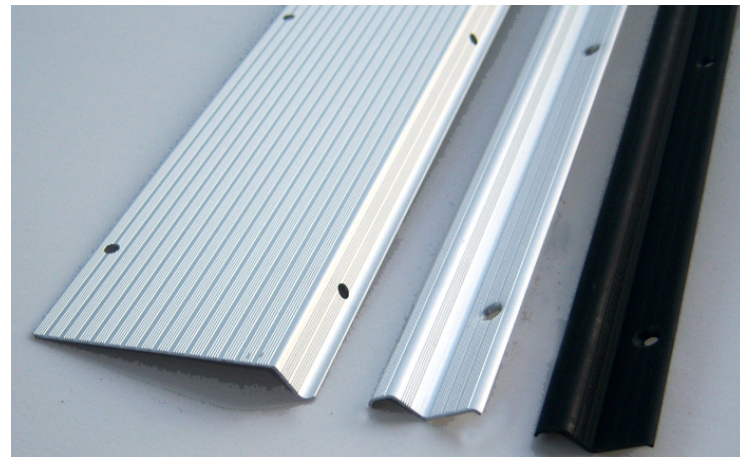

Foot Step Profile Threshold Sill & Carpet Strips

Set of Two. Exact factory match aluminum thresholds and carpet strips. These 4 magnificent pieces, unavailable for years, compliment anyone who opens the doors on your 1970-73 914 or 914/6. Or as Dr. 914 put it, "Thank God somebody made these as now I have a set for my 916!" Exact factory match, cannot be told from the long discontinued factory originals. They are made out of the same high quality 6063 billet aluminum the factory used over 30 years ago. Holes were drilled & countersunk with a CNC machine so they are precise and accurate. Countless hours went into die engineering and nothing was spared to reproduce these hard to find items. They are easily installed with supplied opaque factory rivets and stainless headed Philips screws. The final touch on your concourse restoration. Buy 4 cheaper than the factory original price.

Four-Piece Aluminum Sill and Carpet Strip Set ... [B914 551 137 11 \\$199.50](#)

1



Carpet Strip Screws & Threshold Rivets

Available in black or chrome, these screws are obvious when one opens the door. Avoid the rusty screw look with fresh new ones. Threshold rivets are factory fastening devices are paramount for proper threshold and rocker panel affixing, especially for concours buffs (36 required per car).

1. Carpet Strip Screw, Aluminum ... [R900 145 041 00 \\$1.00](#)

2. Carpet Strip Screw, Black ... [R900 145 063 02 \\$1.00](#)

2





Front Trunk Carpet Kit

Two pieces. Excellent repro set of the original, no-longer-available factory parts. Easily installed, custom cut.

Front Trunk Carpet Kit ... [B914 511 000 00 \\$27.50](#)



Front Tireboard

Fully carpeted and quality stitched.

... [B914 551 029 12 \\$90.00](#)

Wurth Spray Adhesive

Doing some restoration work? This is the perfect companion. We use this in our shops and nothing else compares. The Porsche factory uses Wurth. Why not use the original? This is the product for installing carpet kits, resticking vinyl, or any other application where a general adhesive is needed.

Spray Trim Adhesive ... [RGR1001 \\$15.40](#)



3. Threshold Rivets
... [G999 591 550 40](#)
\$1.27/each

3



356 914
911 944

Porsches...by the numbers!

**We keep them on the road
and in perfect condition.**

In the aftermarket business for more than 12 years, we're dedicated to preserving and restoring all models. Automobile Atlanta has thousands of new & used parts in stock; everything you'd ever need to keep your car the classic that it is.

Our comprehensive catalogs are easy to understand and represent a wealth of experience and expertise. We have parts that even the Factory no longer offers!

Highest quality/lowest price. Technical assistance is always free. Order catalogs by the numbers: specify model when sending check or money order for \$5.00 ea. (refundable w/subsequent order)

**AUTOMOBILE
ATLANTA**

505 S. Marietta Pkwy., Marietta, GA 30060
404/427-2844, M-Sat, 8-7PM, EST.

**VINTAGE AUTO
ATLANTA
ADVERTISEMENT**



Weatherstrip Adhesive

This handy tube glues everything from weatherstrips to the mirror patch! A must for the tool box, we use this adhesive in our shop everyday.

Weatherstrip Adhesive ... [RGR 1001 \\$15.40](#)

THE 914 BODY



Rubber-Backed Plush Logo Floor Mats In Popular Colors

What better addition to your new carpet kit than a set of plush logo mats? The bright lettering brightens the most drab interior, the rubber backing keeps the mats in place, and your carpeting stays clean! These mats are custom fit and available in any color. Most customers order mats to match carpet with "Porsche" in the car's exterior color. **2-Piece Floor Mats ... [RMT 1000 \\$119.95](#)**

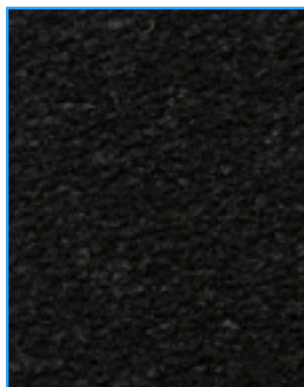

Black



Brown



Sand



Gray



Embroidery available in "914", "914-6" and "Porsche."

*Embroidery available in
any color of the rainbow!*



The Beck 550 Spyder is here! Drive it home or we will ship it to your door with a bow around it for an unbelievable \$27,500.

James Dean, Ike Eisenhower, Lionel Trains, Sputnik, Porsche at its finest; All are recalled the first time one looks upon this legendary car. Porsche originally designed the 550 Spyder to compete on the world's toughest racing tracks, and the car proved itself by compiling an impressive set of victories even over more powerful competitors. Over the years the 550 has become a legend and the few scarce originals are selling for up to a million dollars.

BECK 550 SPYDER

Inspired by this timeless classic and intimately familiar with its superb handling, acceleration, reliability and no compromise design, Chuck Beck took it upon himself to make an improved replica of this fabulous Porsche. Manufactured in Brazil on a sterile assembly line, one cannot help but to be impressed by the high quality, fit and finish, as well as the attention to detail. An exact reinforced duplicate of the original rigid tubular chassis

well bonded to the sleek hand laminated fiberglass body, Chuck running his original 550 for years continually refining the chassis design in his mind until he had it perfect. Beck's design insures maximum cornering power without sacrificing a comfortable ride. The car's light weight allows best use of the 125 horsepower engine.

The car as delivered needs nothing, even including a soft top and detachable side windows and is easily delivered to anywhere in the world. Order yours today and get it in time for Christmas!



THE 914 BODY



Front Trunk Plush Logo Mat Front Carpet Kit

Excellent repro two piece set of the original, no-longer-available factory parts. Easily installed, custom cut.

Front Trunk Logo Mat ... [RMT 2029 \\$95.00](#)
Rear Trunk Logo Mat ... [RMT 2028 \\$132.00](#)



Plush logo mats can beautify your trunk! Have the plush logo look in your front and rear trunk. Great for concours display, tremendous for sound deadening, and a beautiful way to make a 914 statement. These rubber backed mats even double for a picnic blanket!

Some of Our Favorite Screws

Remember when your 914 had all of the right screws? Refresh your memory with reality by again putting the right screw in the right hole per screw.

1. Top Latch 5x15 ... [R900 148 012 02 \\$1.00](#)
2. Lower Rear Window Guide 6x10 ... [R900 146 044 02 \\$1.00](#)
2. Drippan 6x20 ... [R900 146 002 02 \\$1.00](#)
3. Who can remember every screw?
4. Speaker 4.8x22 ... [R900 145 053 07 \\$1.00](#)
4. Speaker 4.8x16 ... [R900 145 030 02 \\$1.00](#)
5. Who can remember every screw?
6. Relay Board 4.8x13 ... [R900 143 015 02 \\$1.00](#)
7. Headlight Relay Cover ??
8. Door Catch/Mirror Exterior ... [R914 531 523 10 \\$1.75](#)
9. Pressure Sensor Bracket ... [R900 138 030 02 \\$1.00](#)
9. Backpad ??
10. 1973-76 Door Latch Surround 5x6 ... [N141 274 \\$1.00](#)
11. Side Box 3.5x19 ... [R900 145 006 02 \\$1.00](#)
11. 1970-73 Aluminum Carpet Strip ??
12. Rear Brake Rotor Rotor Screw Set ... [R900 269 047 09S \\$1.73](#)
13. Center Tray 3.9x13 ... [R900 145 023 02 \\$1.00](#)
14. Silver Carpet Screw ... [R900 145 041 00 \\$1.00](#)
15. Driving Light Grille 3.5x16 ... [RN139 593 \\$1.00](#)
16. Who can remember every screw?
17. Rear Rollbar Chrome 2.9x19 ... [R900 145 050 02 \\$1.70](#)
18. Who can remember every screw?
19. Window Crank 5x8 ... [N142 633 \\$1.00](#)
19. Door Latch Cup 5x12 ... [R900 147 00 402 \\$1.00](#)
20. Console Side 6x15 ... [R900 146 001 02 41.00](#)
21. Headlight Trim (3 required) ... [R341 941 183 \\$1.00](#)
22. Late Rear Window Cap 2.9x6.5 ... [R900 140 032 02 \\$1.16](#)
23. Who can remember every screw?
24. Weatherstrip Gutter 2.9x9.5 ... [R900 143 057 00 \\$1.00](#)
24. Bolster 3.5x9.5 ... [RN139 575 \\$1.00](#)
24. Regulator 3.5x6.5 ... [R900 143 108 02 \\$1.00](#)
24. Door Switch 3.5x19 ... [R900 143 021 02 \\$1.00](#)
25. Who can remember every screw?
26. 1975-76 Black Tag Plate 2.9x19 ... [RN139 443 41.00](#)
27. 1974-76 Black Carpet Strip ... [R900 145 063 02 \\$1.00](#)
28. Black Dash Fascia 4.2x13 ... [G900 145 060 02 \\$0.35](#)

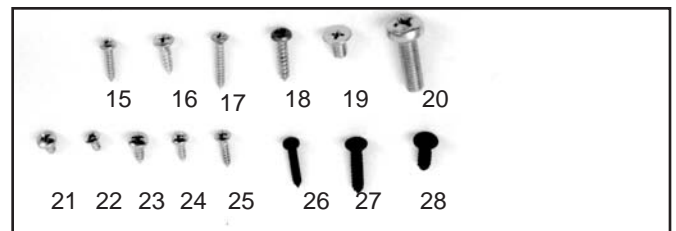
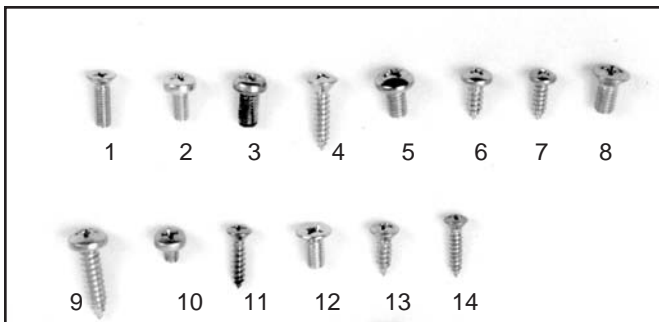

Recovered Door Panel

Our recovered door panels are factory duplicates covered in fresh factory match vinyl. A must for the Concours enthusiast! Please state color when ordering. Black 01, Brown 02, Tan 03, White 04.

Doorpanel \$192.50/each (core \$100.00)

1970 Left Smooth ... B914 555 017 09

1970 Right Smooth ... B914 555 018 09

1971 Left Smooth ... B914 955 017 10

1971 Right Smooth ... B914 555 018 10

1972-74 Left "Brick" Weave ... B914 555 283 10

1972-74 Right "Brick" Weave ... B914 555 284 10

1975-76 Left Basket Weave ... B914 555 283 11

1975-76 Right Basket Weave ... B914 555 284 11

EACH, \$192.50

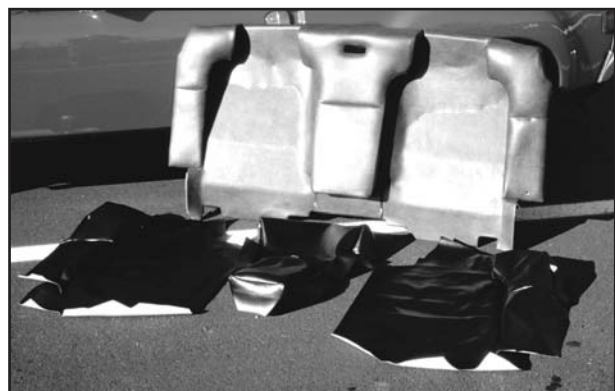

Back Pad Recovering Kit

Our back pad recovering kit does a flawless job of renewing your torn or damaged back pad vinyl. Our seamstress works her fingers to the bone, putting all of the original stitching in these pieces. We offer all factory colors so you can have professional results in little time with very little money! Black 01, Brown 02, Tan 03, White 04.

1970 Back Pad Recovering Kit ... [B914 555 061 09 \\$137.50](#)

1971 Back Pad Recovering Kit ... [B914 555 061 10 \\$93.50](#)

1972-76 Back Pad Recovering Kit

... [B914 555 061 12 \\$115.50](#)



Fiberglass Deposit Box

Now a solution for the warped NLA cardboard left deposit box! A new reproduction fiberglass one. Covered in factory match black vinyl, it will never warp again!

Reproduction Deposit Box ... [B914 555 021 00 \\$150.00](#)

Rear Trunk Carpet

Beautiful rendition of the factory original piece, complete with the foam backing. Perfect for the original restoration.

Rear Trunk Carpet, 1970-71 ... [B914 551 040 10 \\$55.00](#)

Rear Trunk Carpet, 1972-74 ... [B914 551 040 11 \\$55.00](#)

Rear Trunk Carpet, 1975-76 ... [B914 551 044 10 \\$55.00](#)

G = Genuine • R = Aftermarket / Replacement •
U = Used • B = Rebuilt or Reproduction

THE 914 BODY



Upper Roll Bar Pad

For 914-6. Reskinned. \$150.00 core charge.

Upper Roll Bar Pad ... [B914 552 097 10 \\$450.00](#)

Door Panel Hardware Kit

We have both early and late. Includes a variety of critical parts to connect the door panel to the door. (As pictured or order extra clips and receivers.) Kit does two panels.

1. 1970-74 Kit ... [BAA 555 \\$21.45](#)

2. 1975-76 Kit ... [BAA 556 \\$16.50](#)

BUY TWO!

Interior Plugs and Cup Washers

1. Small (Bolsters) ...

G914 552 233 10 \$3.60

2. Large (Door Pocket
& Lower Dash) ...

G914 555 129 10 \$1.00

3. Cup Washer for
Door Pocket Trim

Screws ... R999 591

011 12 \$3.30

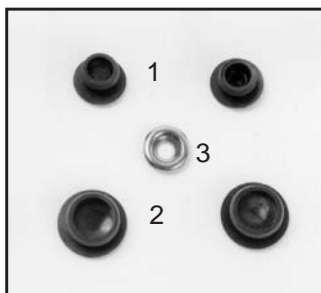

Recovered Dash Pad

Extremely upset that the Porsche factory discontinued the original factory dash, and knowing that he had saved every used cracked 914 dash from the beginning of time, Dr. 914 came up with an acceptable solution: a completely reskinned original dash. All of the old vinyl is completely removed and the top of the dash is virtually remanufactured with brand new factory-matched vinyl. The process is expensive and time-consuming but well worth it for the 914 perfectionist/restorer.

Recovered Dash Pad ... [B914 552 031 12 \\$650.00](#)



914 Dash Cover

If you are tired of the unsightly cracked 914 dash, but on a budget, then purchase this excellent glue-on plastic cover! It exactly covers the dash top with a similar grained vinyl look. Black only.

Dash Cover ... [RDC 3004 \\$98.94](#)

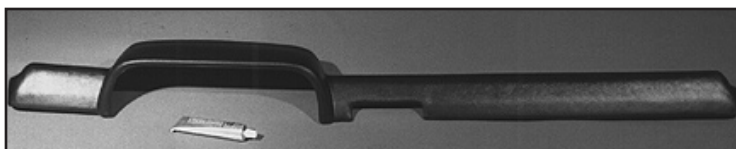

Dash Kit - Carbon Fiber or Wood Colors

Great dash kits for your 914 to restore an aged look or change the appearance altogether. Kit contains 5 pieces to complete your dash and center console. Installing our dash kits is really quite simple, about 45-75 minutes depending upon your skill level. Our dash kits use 3M Primerless Acrylic foam Tape for super attachment of interior trim. No priming is required. Compatible with the newest interior plastics, this double-sided adhesive has field proven reliability. No tape promoter is needed like other dash kits require. Dash kits that use a promoter actually destroy your original dash by forcing the dash to chemically bond with their adhesive. 3M's promoter-less adhesive does not require a physical chemical bond to maintain adhesion. If for some reason in the future, you were to choose to remove our dash kit, you can do so without ruining your original dash. Simply ensure your dash is cleaned thoroughly with 3M Prep Solvent 70 before you apply our dash kit.

Dash Kit, Carbon Fiber Color ... [BSU5155 \\$219.45](#)

Burlwood Color ... [BSU5151 \\$258.50](#)

Rosewood Color BSU5152 \$258.50

White, Red, Green, Yellow, Black and Orange also available!



Carbon Fiber



Burlwood



Rosewood

Factory Mirror and Replacement Glass

Don't throw away a perfectly good factory mirror just because the glass is cracked! Replace it easy with one of our handy mirror replacement glasses. Cut from the original pattern, the glass is easily installed in seconds! Two sizes of glass were original; 5" and 5 1/4". Measure yours to be sure.

Factory Mirror ... [G914 731 939 10 \\$204.49](#)

Factory Mirror Replacement Glass (Specify Size) ... [B914 731 939 10 \\$15.00](#)

Factory Mirror Screws (Two Req'd) ... [R914 531 523 10 \\$1.75](#)

Factory Mirror Gasket ... [B914 731 116 10 \\$4.84](#)



Upper Dash Kit

Upper Dash Face Complete with smooth vinyl and padding this kit contains plenty of material to completely recover the peeling upper dash. (Must drop dash or remove windshield and dashpad to install.)

Upper Dash Kit ...
B914 552 021 10 \$22.00

Dash to Windshield Bead

The best time to replace this part is when you are replacing the windshield. Easily installed, it is a compliment to any upper dash. Genuine has metal in it and squeezes onto the channel. Repro glues onto the channel.

Genuine Dash to W/S Bead ... [G914 552 263 10 \\$107.78](#)

Repro Dash to W/S Bead ... [R914 552 263 10 \\$39.50](#)

Vinylex Vinyl Cleaner

1/2 liter. Vinylex Will Keep Your Vinyl Looking New. Vinylex cleans, conditions, protects, and renews vinyl, rubber, and plastic without leaving that freshly-greased look. It protects against fading, cracking, and drying caused by age, environmental pollution and ultraviolet rays. Great 1/2 liter size with sprayer top.

Vinylex Vinyl Cleaner ... [RGR5003 \\$13.14](#)



THE 914 BODY

Aluminum Gauge Plate

This cluster is laser cut from a billet aluminum and has brushed aluminum (unpainted) finished. It will fit all modern size instruments and 1/2 inch wide holes for warning lights (see part number BMB 241 73). Warning lights are located inside the original instruments. They are: Alternator, Brakes, Oil, Parking, High Beam, Turn. Other kinds of Autometer products can be fitted inside. Our site features an entire Autometer inventory for your needs. In addition, VDO and Autometer sell this inexpensive device to convert a mechanical speedometer cable to the electronic impulse signal. Old cluster has outdated size openings to have the ability to install modern-size instruments. We will ship this cluster with 1/8 thick cardboard template simulating this cluster, so you can practice and pre-plan the installation before actual piece is installed.

Aluminum Gauge Plate ... [RMB24172 \\$95.00](#)



914-6 Steering Column Trim

914-6 decal set for steering column One of the nicer finishing touches for your six restoration, or a great way to learn how to operate the column switches! Original factory equipment but slightly different than the production set.

914-6 Steering Column Trim ... [G901 559 330 01 \\$55.91](#)

Baby Tornado Mirror

Our most popular! Aerodynamic shape for an un-intruding look. Includes "Visual Filter" technology for driver comfort. Black matte finish with universal mounting. Passenger side includes a Panoramic wide angle lens for added safety.



Baby Tornado Mirror, Left ... [RVT5567 \\$88.00](#)

Baby Tornado Mirror, Right ... [RVT5568 \\$88.00](#)

Steering Column Covering, 914-6

Beautiful repro of this long-discontinued part.

A must for concours!

Steering Column Covering, 914-6

... [B914 541 173 10 \\$19.50](#)



1970-74

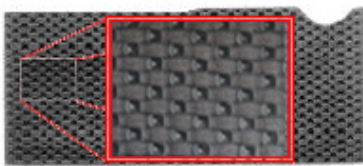

1975-76

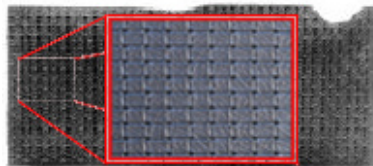

DIN Radio Face Plate

Has your radio face plate been ruined from previous installation? Try one of our brand new ones! Available in regular or DIN cuts. It highlights any stereo installation!

DIN Radio Face Plate, 1970-1974

... [B914 552 040 11 \\$27.50](#)

DIN Radio Face Plate, 1970-1974, For Newer Radios

... [B914 552 040 A2 \\$24.20](#)

Gauge Holder & Rings

If your 914 does not have the center console and you need a VDO gauge holder. Available in both steel and

Holder Single Steel ... [RVDO 240 027 \\$13.75](#)

Holder Single Rubber... [RVDO 240 802 \\$27.44](#)

Holder Double Steel ... [RVDO 240 028 \\$19.25](#)

Holder Double Rubber ... [RVDO 240 803 \\$31.84](#)

Holder Triple Steel ... [RVDO 240 029 \\$26.95](#)

Holder Triple Rubber ... [RVDO 240 804 \\$32.94](#)

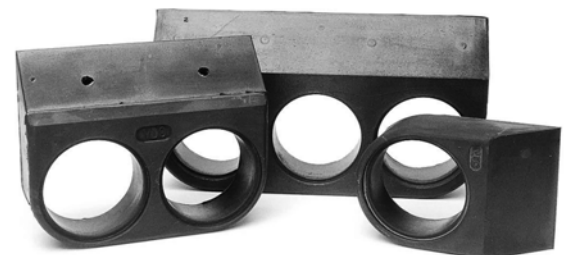



911 Mirrors for 914

Bring your older Porsche up-to-date with these striking aero mirrors. They retain electrical operation and attach to the existing mirror mounts so there's no need to drill new holes. Kit includes two mirrors and housings.

Mirror Update Kit ... [G964 731 901 02ESZ \\$415.00](#)

Californian Mirrors

Californian Mirror Sleek design! This is the ultimate in aerodynamic mirrors with state-of-the-art Vitaloni technology. Will withstand racing windspeeds. Passenger side includes a Panoramic wide angle lens for added safety.

Californian Mirror Left ... [RVT5784 \\$93.50](#)

Californian Mirror Right ... [RVT5789 \\$93.50](#)



Dash Saver Mat, Carpet, Fabric

Save that dash and your eyes! Keep your dash looking new by protecting it from the sun and elements with our luxurious plush dash mat. Cover a cracked or faded dash in seconds and add a fantastic companion to your floor and hatch mats. Not only does it soothe the eyes by hiding cracks in the dash, but also eliminates dash glare in your windshield! The custom cover for an additional \$25.00, includes your choice of embroidery. The dash cover is available in Black or Brown (specify color when ordering).

Dash Saver Mat, Carpet ... [R1056301 \\$76.94](#)

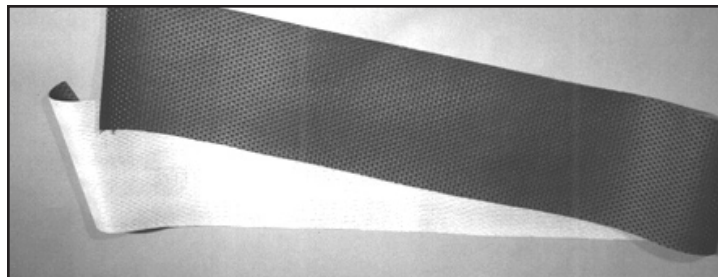

Dash Face Material

Our dash face material kit is the genuine article and brightens the sagging, peeling fifteen-year-old face panel. Installation is easy with spray trim adhesive!

70-74 Kit, Black ... [B914 552 011 \\$22.00](#)

75-76 Kit, Black ... [B914 552 012 \\$22.00](#)

NEW ITEM!



Repro Visor Clip

Save!

Left Visor Clip ... [B911 731 323 41 \\$19.50](#)

Right Visor Clip ... [B911 731 324 41 \\$19.50](#)

Center Visor Clip ... [B914 731 327 10 \\$19.50](#)

Recovered Visors

New foam padding, new vinyl, nice! Core charge \$75.00.

Passenger's Side Recovered Visor ... [B901 731 018 10 \\$175.00](#)

Driver's Side Recovered Visor ... [B901 731 017 10 \\$175.00](#)

THE 914 BODY



Rear View Mirror Interior

Beautiful factory replacement mirrors.

Rear View Mirror Interior, 914 Style ... [G914 731 014 11 \\$187.72](#)

Rear View Mirror Interior, 944 Style to Fit 914

... [R477 857 511A \\$75.00](#)

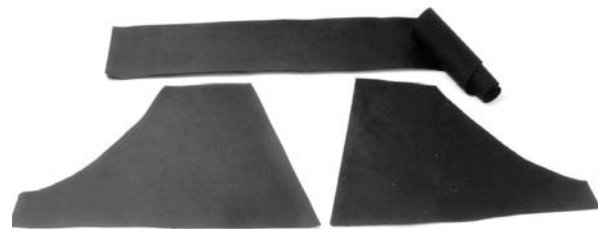

Side Vinyl Kit

All 914 rollbars are peeling by now. Freshen it with new vinyl! Easily installed with spray trim adhesive, our kit is made from the exact German material and is custom cut into three perfect fit pieces at a fraction of dealer price.

Roll Bar Vinyl Kit ... [R914 559 266 \\$92.75](#)

Mirror Base Gasket... [R901 731 133 20 \\$4.82](#)

Mirror Mount ... [G477 845 043 \\$9.88](#)

Emblems

Brighten up your 914 by replacing damaged or missing emblems. Original factory emblems at a great price, the final touch for your restoration project.

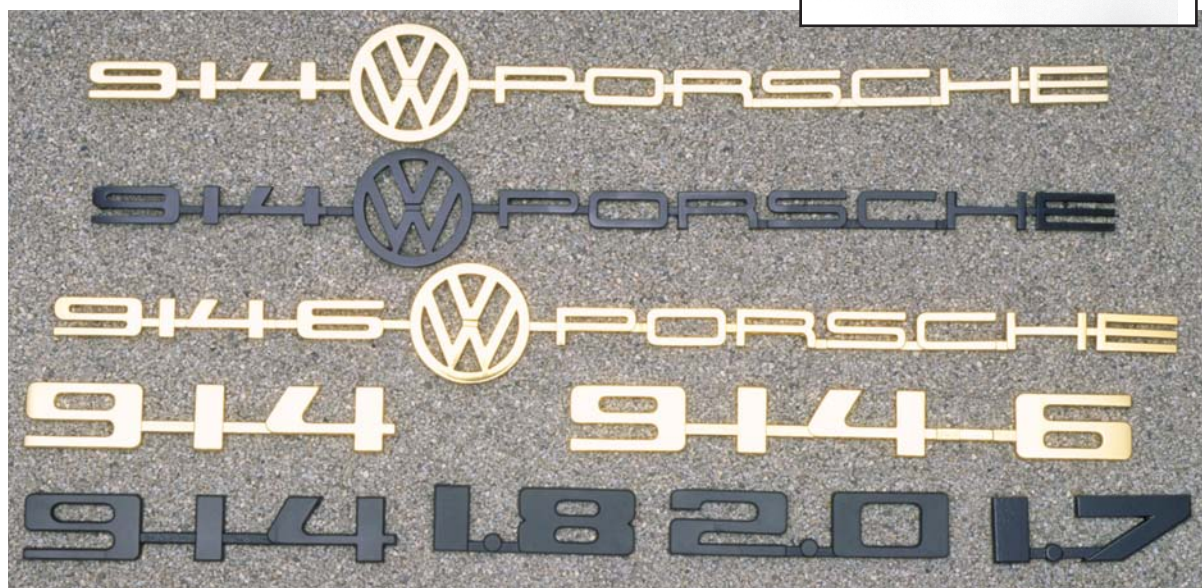
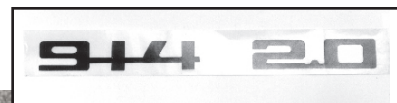

1. 914-6 Emblem, US Version (Gold) ... [G914 559 114 10 \\$68.83](#)
2. 914-6 VW Porsche Emblem (Gold) ... [G914 559 112 10 \\$145.00](#)
3. 914-4 1973-74 Emblem (Black) ... [G914 559 287 11 \\$30.30](#)
4. 914-4 2.0 1976 Emblem (Adhesive Foil) ... [R914 559 293 11 \\$19.43](#)
5. 914-4 1973-76 2.0 Emblem (Black Plastic) ... [G914 559 120 11 \\$26.50](#)

6. 914-4 1973-76 1.8 Emblem (Black Plastic) ... [G914 559 459 10 \\$28.70](#)
7. Black 1973-74 914 VW Porsche ... [G914 559 289 10 \\$61.02](#)
8. Gold 914 VW Porsche ... [G914 559 111 10 \\$97.57](#)
9. Gold 1970-72 914 Emblem ... [G914 559 288 11 \\$72.00](#)
10. "1.7" Black 1973 Emblem ... [G914 559 115 10 \\$93.45](#)

Clips For Emblems

- A. Large Clips for Engine Grille or Engine Grille Lettering ... [R999 591 423 03 \\$1.25/each](#)
- B. Small Clips for Rear Script ... [B999 591 211 01 \\$1.50/each](#)
- C. Large Clips for Engine Grille (original style, rubber covered) ... [G999 507 220 40 \\$2.16/each](#)

Enameled Car Badges

Add international glamour to your automobile. These high quality, enameled badges have bright colorful images on a shiny chrome background.

German Flag ... [RAC 2071 \\$20.90](#)

Deutschland Eagle ... [RAC 2009 \\$20.90](#)

USA Flag ... [RAC 2010 \\$20.90](#)

Stuttgart Horse ... [RAC 2024 \\$20.90](#)



Appearance Stripe Kits

An original dealer installed item and factory equipment (negative stripe) on the 1974 Special Editions, we have the stripes! What a great way to dress up your 914 or restore its original appearance. They are also easy to install using a little soapy water and masking tape guide line. Negative Stripes are available in black, gold, silver, white, orange or yellow. Positive stripes are available in black and white only.

Negative Stripe (Specify color) ... [GSS 1002 \\$115.00](#)

Negative Stripe (Specify color) ... [RSS 1002 \\$35.00](#)

Positive Stripe (Specify color) ... [RSS 1009 \\$35.00](#)



Window Tint

If the sun is killing your eyes, this window tint is for you! (It also gives your Porsche a bold factory identity and keeps your interior cooler.) This item is statically installed. Window tints similar to the one left were dealer installed options on Porsches.

Window Tint ... [BAC2016 \\$28.60](#)



Rear Deck Lid Stripe

An original dealer installed factory accessory dug out of the lost warehouse! This beautiful stripe matches the Porsche positive racing stripes and recalls the 914s magical mystery tour of the '70's! Available in both black & white, you can now identify your 914 as one of the rare factory striped versions!

Rear Deck Stripe White ... [GZPW 146 115 \\$19.50](#)

Rear Deck Stripe Black (pictured) ... [GZPW 146 114 \\$19.50](#)

Driving Light Grille Screw & Clip Set

Whenever you replace the driving light grilles, it is then that you find out that the hardware looks bad! Complement your new grilles with new hardware. Eight screws, eight clips - everything you need for a perfect installation.

Driving Light Screw/Clip Set ... [B914 559KIT \\$10.00](#)

Chrome Driving Light Grilles

Specify left or right.

Chrome Driving Light Grille, Left ...

[G914 559 235 10 \\$138.61](#)

Chrome Driving Light Grille, Right

... [G914 559 236 10 \\$138.61](#)

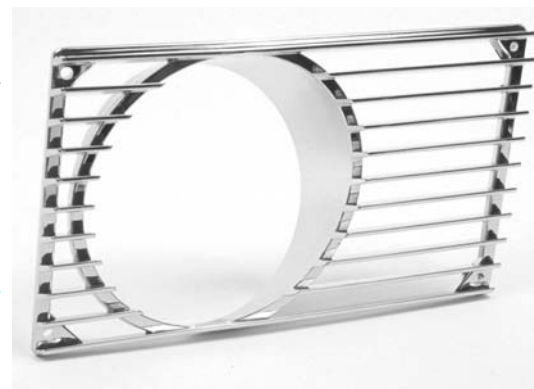

THE 914 BODY



Engine Grille Lettering

Plastic chrome "Porsche" lettering kit is a duplicate of the original chrome plastic letters installed on the engine grille of all 74-76 914 models. The kit includes seven plastic chrome letters, fourteen clips, and a lettering grid for placement. Easily installed, but remember not to tighten the nuts too much or the lettering peg will break!

Engine Grille Lettering, Silver ... [BPNA559 901 00 \\$65.00](#)
Engine Grille Lettering, Gold ... [G901 559 301 22 \\$79.50](#)

Clips

Large clips for engine grille. Original style, rubber covered. 12 required.

Engine Grille Clips, Aftermarket Style ... [G999 507 220 40 \\$2.16/each](#)
Engine Grille Clips, Original Style ... [G999 507 220 40 \\$2.16/each](#)



Spray Adhesive

Doing some restoration work? This is the perfect companion. We use this in our shops and nothing else compares. Why not use the original? This is the product for installing carpet kits, resticking vinyl, or any other application where a general adhesive is needed.

Spray Trim Adhesive ... [RGR1001 \\$15.40](#)



Engine Insulator Pad

"Kill the Noise." This exact reproduction of the original, no-longer-available Porsche part is a perfect die-cut replacement made with genuine dynamat material and includes an extra super stick-on insulator for the greatest in sound absorption. Easily passes the most rigorous concours judge's muster.

Insulator Pad ... [B914 556 135 10 \\$199.50](#)

Floor Pan Tar Premade Kit

Now, a perfect premade solution to installing the floor pan insulation over your freshly installed floor pan. These custom kits are made exclusively for us by our friends at Dynamat and are a perfect fit. Now floor pan insulation installation is a breeze!

Six-Piece Floor Pan Tar Premade Kit ... [B914 556 110 KT \\$175.00](#)

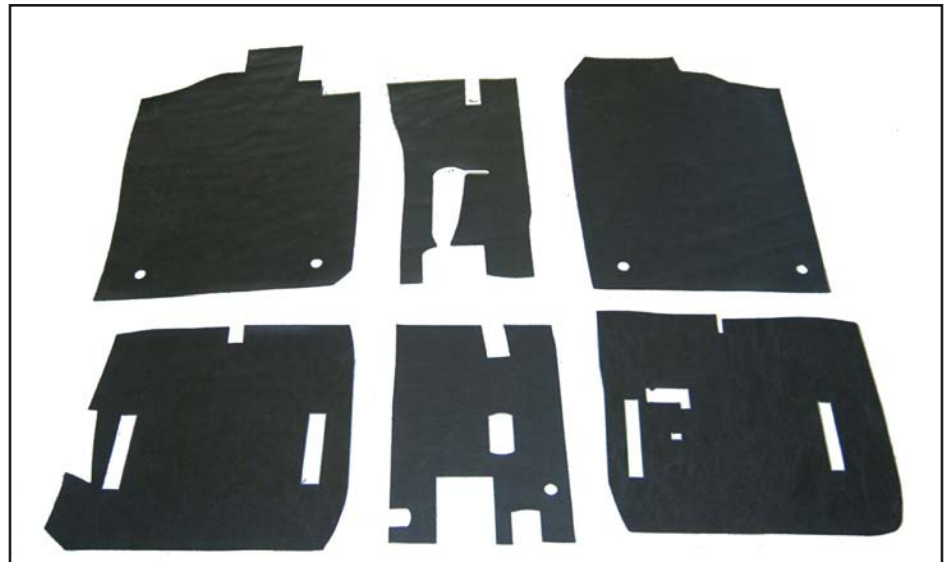

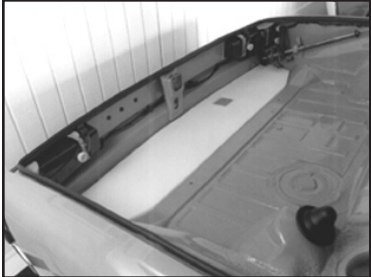

Rear Trunk Insulator Pad

A beautiful copy of the original 70-72 trunk insulator pad. No concours restoration is complete without it.

- Rear Insulator Pad, 1970-72 ... [B914 556 271 10 \\$46.75](#)
- Rear Insulator Pad, 1974-76 ... [B914 556 003 10 \\$75.00](#)



Weatherstrip Adhesive

This handy tube glues everything from weatherstrips to the mirror patch! A must for the tool box, we use this adhesive in our shop everyday.

- Weatherstrip Adhesive ... [RGR 1001 \\$15.40](#)

Engine Insulator Pad Clip Set

Discontinued by Porsche, but we have them!

- Engine Insulator Pad Clip ... [R914 559 377 10 \\$3.50](#)



Wurth Brushable Seam Sealer, Quart

The factory uses gallons of this when they build their German automobiles. If you do any body repairs or replace a fender, make sure it is resealed for a proper repair. Prevents rust and corrosion.

- Wurth Brushable Seam Sealer, Quart ... [RGR1019 \\$36.78](#)



Windshield Top Seal, Topside Seal and Vertical Rollbar Seal Kit

Everyone hates the chronic water leaks. Solve them today with careful filament of these new seals. This list is of the factory original replacements - repros available on page 123.

- Left Vertical Rollbar Seal ... [R914 531 821 10 \\$68.15](#)
- Right Vertical Rollbar Seal ... [R914 531 822 10 \\$68.14](#)
- Windshield Topseal ... [B914 563 039 10 \\$199.50](#)
- Left Topside Seal ... [R914 531 185 10 \\$63.52](#)
- Right Topside Seal ... [R914 531 186 10 68.30](#)

*Check for current availability. We are looking for our tooling!

Hardtop Side Seal

This is the seal that fits on the passengers side of the hardtop and the one that the side glass rolls up and hits. Easily replaced with a wide blade screw driver and some silicone grease just fit the inner side into the channel and then pinch the outside in with a screwdriver. Remember not to cut it short as it will shrink to fit! We have a tube of silicone grease available to help with the installation.

- Top Side Seal, Left ... [B914 531 186 10 \\$38.50](#)
- Top Side Seal, Right ... [B914 531 185 10 \\$38.50](#)



THE 914 BODY



Beautifully Refinished Targa Top Roof

914 1970-76. Core charge \$200.00.

Refinished Targa Top

... [R914 563 901 11 \\$600.00](#)

Top Bolster Plugs

... [G999 703 013 50 \\$2.66](#)



Front and Rear Trunk Carpet Kit With Headliner, Charcoal Felt

Reproduction kit includes front & rear trunk floors, front bulkhead and top headliner.

Headliner ... [B914 563 511 321 13 \\$27.50](#)



Rubber Kit - Our Most Comprehensive Kit Ever!

Our rubber kits are for the perfect restoration. Beware of imitation kits that often make you buy what you don't need just to get desired pieces! This kit consists of everything we use in our restoration shop without going overboard! Restores your 914 perfectly! Factory windshield top seal included!

Rubber Kit ... [BAA500 \\$850.00](#)

Includes:	1 Blower Box Seal
2 Side Marker Seals	2 Top Side Seals
2 Front Turn Signal Seals	2 Vertical Rollbar Seals
1 Front Hood Seal	4 Door Latch Gaskets
2 Washer Jets (Black)	2 Jack Hole Plugs
2 Wiper Caps	1 Rear Trunk Seal
2 Fender to Cowl Seals	1 Rear Lid to Glass Seal
1 Dash to Windshield Bead	1 Rear Top Seal
1 Windshield Top Seal	2 Taillight Seals
2 Squeegees	1 Engine Lid Welting
2 Door Frame Seals	

Replacement Rubber Pieces

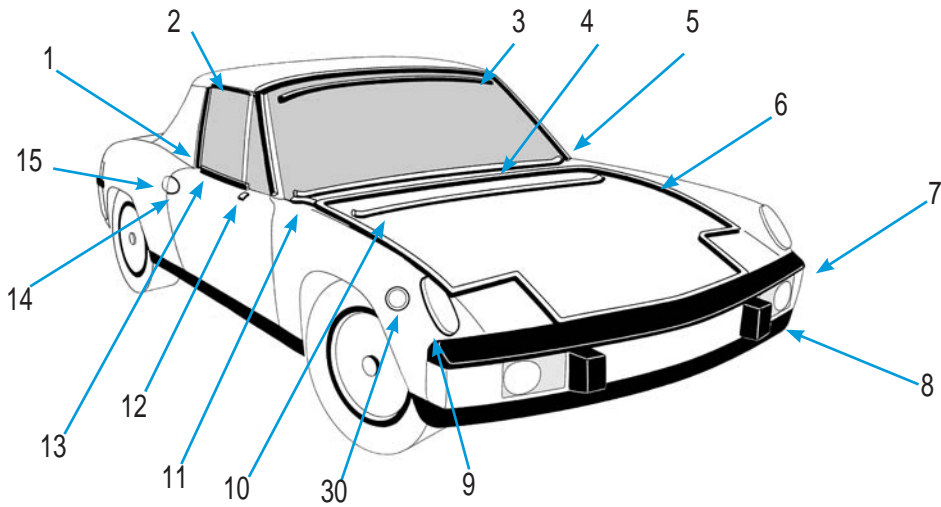

		Genuine	New	Repro
1. Rollbar Side Seal Left	914 531 143 10	\$105.59	\$82.78	\$38.50
1. Rollbar Side Seal Right	914 531 144 10	\$105.93	\$82.78	\$38.50
2. Hardtop Side Seal Left	914 531 185 10	\$99.97	\$63.52	\$38.50
2. Hardtop Side Seal Right	914 531 186 10	\$99.61	\$63.80	\$38.50
3. Hardtop Front Inner	914 563 319 10	\$146.15	\$93.50	-
4. Windshield Lower	914 552 263 10	-	\$107.78	\$39.50
5. Hardtop Front (Wind/Doors)	914 563 039 10	\$375.00	-	\$199.50
6. Front Hood Seal	914 511 901 10	\$207.65	\$180.76	\$59.50
7. Front Bumper Pad 1970-74	914 503 023 10	\$512.33	\$425.00	-
7. Front Bumper Pad 1975-76	914 503 231 12	\$742.27	\$644.68	-
8. Front Bumper Guard 70-74 Left	914 505 063 10	\$265.72	\$175.00	-
8. Front Bumper Guard 70-74 Right	914 505 064 10	\$286.46	\$175.00	-
8. Front Bumper Guard 75-76 Left	914 505 189 10	\$98.26	-	-
8. Front Bumper Guard 75-76 Right	914 505 190 10	\$90.40	-	-
9. 914 Turn Signal Seal	914 631 957 10	\$45.18	-	\$12.00
10. Front Bulkhead Seal	914 511 902 10	\$77.57	\$80.27	\$30.00
11. Fender to Cowl Seal	914 559 155 10	\$9.95	-	\$3.00
12. Mirror Base Seal	914 731 116 10	\$11.00	-	\$4.95
13. Door Window Scraper Left	914 531 873 10	\$15.83	\$9.82	\$7.50
13. Door Window Scraper Right	914 531 874 10	\$15.73	\$9.82	\$7.50
14. Large Door Handle Seal 70-76	PCG 531 601 00	\$49.05/set	-	\$4.50
15. Small Door Handle Seal 70-76	PCG 531 603 00	\$49.05/set	-	\$4.50

		Genuine	New	Repro
16. Ventwing Glass Seal Left	914 542 325 10	\$119.38	\$106.00	-
16. Ventwing Glass Seal Right	914 542 326 10	\$119.38	\$94.05	-
17. 914 Vent Window Cap	914 542 017 10	\$85.11	-	-
18. Rear Window/Engine Seal	914 512 319 10	\$99.00	-	\$39.50
19. Rear Trunk Seal, Front	914 512 315 10	\$101.59	\$69.30	\$30.00
20. Hardtop Rear Seal	914 563 077 11	\$481.58	\$375.00	\$75.00
21. Engine Shroud Seal Frt, L or R	914 504 155 10	\$48.62	\$38.65	-
21. Engine shroud Seal Rear	914 504 117 10	\$97.20	-	\$44.00
22. Rear Trunk Seal, Rear	914 512 317 10	\$114.62	\$72.19	\$30.00
23. Rear Bumper Pad 1970-74	914 503 027 10	\$512.41	\$375.00	-
23. Rear Bumper Pad 1975-76	914 503 233 10	\$838.91	\$669.00	-
24. Rear Bumper Guard 70-74 L	914 505 085 10	\$267.72	\$144.38	-
24. Rear Bumper Guard 70-74 R	914 505 086 10	\$281.64	\$144.38	-
24. Rear Bumper Guard 75-76 L	914 505 191 10	\$165.28	-	-
24. Rear Bumper Guard 75-76 R	914 505 192 10	\$167.57	-	-
25. Tow Eye Plug (Primed) 70-74	PCG 722 107 10	\$4.55	-	-
26. Jack Plug Cover	914 559 267 10	\$12.50	\$3.24	-
27. Outer Door Seal Left	914 531 813 10	\$133.73	\$98.18	\$38.50
27. Outer Door Seal Right	914 531 814 10	\$133.73	\$98.18	\$35.00
28. Inner Door Seal On Body Left	914 531 821 10	\$87.05	\$68.15	\$30.25
28. Inner Door Seal On Body Right	914 531 822 10	\$87.05	\$68.15	\$30.25
29. Taillight Lens Seal (Set of 2)	914 631 939 00	-	-	\$16.50
30. Sidemarker Seal	914 631 405 06	-	-	\$8.80

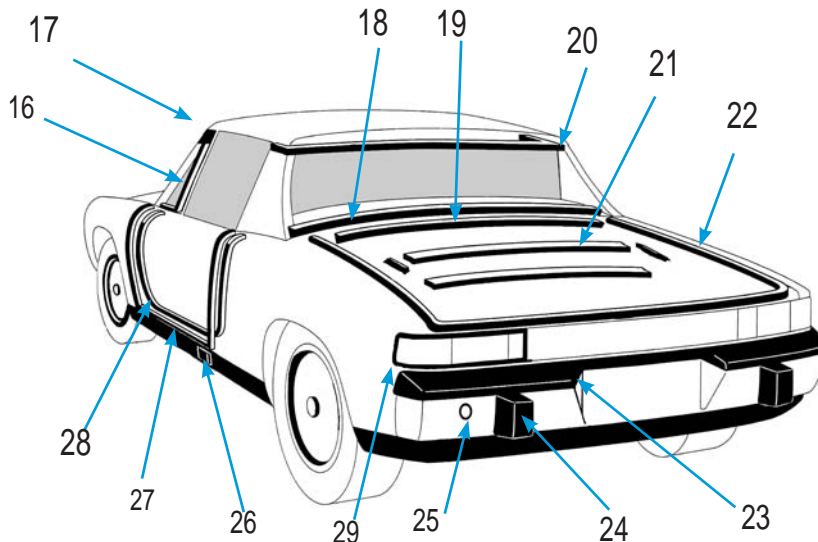

THE 914 BODY



LOWER WINDSHIELD SEAL

This is the lower of the two front windshield seals, and the one with the notch in it. It is below the upper top seal that can be seen when the roof is in place. Seal is about three feet long

Lower Windshield Seal ... [R914 563 319 10 \\$93.50](#)



Protect Your 914 Investment With One Of Our Perfect-Fit 914 Covers To Block Damaging UV Rays And Provide Water Resistance

WE SELL COVERS FOR ALL AUTOS. ORDER ONE FOR YOUR OTHER CAR TODAY!

Car covers are a great way to protect your investment. Ultraviolet rays alone can ruin your 914, so never park in the sun without covering your car. Polycotton covers provide excellent protection, while the heavier Technalon adds water resistance, and the Flannel cover is for Concours buffs where bathing the paint inside your garage is your first concern. For security and storage order the bag and locking kit.

Technalon Car Cover ... [RCC32TK \\$186.94](#)
Polycotton Car Cover ... [RCC 1001 PD \\$175.95](#)

Flannel Car Cover ... [RCC 1001 TF \\$197.94](#)
Locking Kit & Storage Bag ... [RCC 1002 \\$15.00](#)

Seat Belt Set

Left and Right. Finally a solution for the lousy non-retractable, no longer available, 1970-71 seat belts! Brand new, retractable seatbelts bolt right in, work great, and encourage you to be safe! No more fumbling with old dirty belts!

Seat Belt Set, 1970-1971 ... [B914 803 903 10 \\$485.00](#)



These replace these!





Rear Targa Top Seal

Beautiful reproduction of this expensive factory seal is now available! An exact duplicate of the latest and greatest the factory makes, this seal is easily installed with a screwdriver and a punch to make the pilot holes in the seal. You will love eliminating the squeak! Lubricate with silicone grease

Rear Targa Top Seal ... [B914 563 077 11 \\$95.00](#)
 Factory Targa Seal ... [R914 563 077 11 \\$481.58](#)

Tech Tips 700

By Dr. 914. Newly printed third edition, Tech Tips 700 is the bible when it comes to guides or manuals to operate and maintain your Porsche 914. This little red book has been hailed by 914 owners as a must have companion to their beloved cars. Road & Track magazine says that no 914 owner should be without it.

Add an extra buck and Dr. 914 will personally sign your book!

Tech Tips 700
 ... RBK 7074 \$19.95

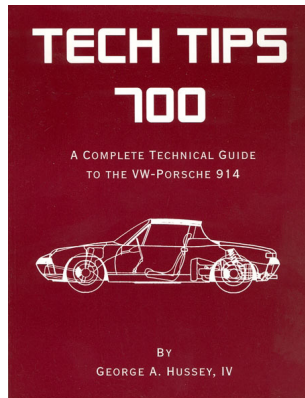

Press Sign for Late Seatbelts

This is the press sign on the seatbelt receiver for all late 72-76 914s. These always fade and give your otherwise pristine interior a faded look. Renew the sticker with one of our bright orange and black repros! Easily installed with sticky backing.

Set of Two "Press" Signs
 for Late Seatbelts
 ... [B914 803 183A Set of Two. \\$6.50](#)



914 TORQUE SPECS

Engine	LB F FT	KG F M
Oil Drain Plug	16.0	2.2
Retaining Nut for Oil Screen Cover	9.4	1.3
Nuts for Rocker Arm Shaft	10.0	1.4
Cylinder Head Nuts	23.0	3.2
Engine Support Bolts (crankcase)	21.7	3.0
Bolt for Blower Impellor Hub	23.0	3.2
Flywheel Bolts	80.0	11.0
Bolts and Nuts for Crankcase Halves	14.5	2.0
Nuts for Crankcase Halves (with O-Ring on outside)	24.0	3.3
Connecting Rod Nuts (new nuts, lubricated threads)	24.0	3.3
TORQUE WRENCH SETTINGS		
Transmission Support Nuts	14.5	2.0
Engine Support Nuts (Body)	21.7	3.0
Nuts Securing Engine to Transmission	21.7	3.0
Nut for small V-Belt Pulley	43.4	6.0
Cooling Blower Impellor Bolts	14.5	2.0
Transmission	LB F FT	KG F M
Transmission Housing Cover Stud Nuts	16-18	2.2-2.5
Fork Piece on Housing	15-17	2.1-2.3
Throwout Bearing Guide Tube	7	0.8-0.9
Oil Filler Plug	15-18	2.0-2.5
Drain Plug	15-18	2.0-2.5
Bearing Throwout Fork	15-17	2.1-2.3
Breather	15-22	2.0-2.3
Backup (reverse) Light Switch	25-29	3.5-4.0
Throwout Fork Holding Plate	6-7	0.8-0.9
Starter Nuts	33-35	4.6-4.8
Intermediate Plate Clamping Plate	15-17	2.1-2.3
Intermediate Plate Guide Lever Bolt	15-17	2.1-2.3
Gearshift Lock Plug	16-18	2.2-2.5
Speedometer Drive	12-13	1.6-1.8
Guide Bushing Miter Drive Hollow Screw	16-18	2.2-2.4
Driveshaft Nut	72-86	10-12
Driveshaft Castellated Nut	65-80	9-11
Pinion Shaft Expansion Bolt	80-87	11-12
Shift Fork Screws	18-19	2.4-2.6
Differential Housing Ring Gear	72-86	10-12
Drive Flange Expansion Bolt	25-29	3.5-4.0
Rear Cover Shift Rod Bearings	15-17	2.1-2.3
Rear Trans. Cover Plate Nut	6-7	0.8-0.9

THE 914 BODY



Seat Belt Retractor/Belt Hardware Set

Tired of seat belts not retracting? Don't take a chance with your life! Install a new set! Order attachment bolts below.

Seat Belts (Left and Right set) ... [G914 803 90310 \\$299.00](#)

Attachment Parts:

1. Upper Bolster Bolt ... [G481 857 757 \\$6.89](#)
2. Lower Rocker Bolt ... [G481 857 757 \\$6.89](#)
3. Lower or Upper Washer ... [G111 857 707A \\$4.61](#)
4. Bolster Wave Washer ... [G900 028 026 01 \\$1.00](#)
5. Retractor Washer ... [G999 523 109 02 \\$41.00](#)
6. Lower or Upper Plastic Washer ... [G211 857 771 \\$1.00](#)
7. Retractor Bolt ... [G111 857 799 \\$3.60](#)



Sparco 4-Point Harness Belt

For the safest restraint! Red or blue.

Sparco 4-Point Harness Belt ... [RSP0969 \\$196.90](#)

AUTOMOBILEATLANTA
WHOLESALE DIRECT

PARTS SEARCH CART CHECKOUT HOME



Since 1978 Automobile Atlanta has provided the best in Porsche parts and now offers all European and Asian parts directly from our importers. Lowest prices in the industry. Check your mechanic's arithmetic! Top quality OEM parts only. Instant stock check and same day shipment. The best in technical advice is always available.

We carry parts for all European and Asian cars:
Acura, Austin Healey, Audi, BMW, Daihatsu, Honda, Hyundai, Infiniti, Isuzu, Jaguar, Jensen Healey, Lexus, Mazda, Mercedes Benz, MG, Mitsubishi, Nissan, Porsche, Rover, Rolls Royce, Saab, Subaru, Suzuki, Toyota, Triumph, Volvo, Volkswagen

[Home](#) | [Checkout](#) | [Track Order](#) | [Online Catalog](#) | [Mailing List](#) | [Terms](#) | [Privacy](#) | [Contact Us](#)
Visit [AutoAtlanta.com](#) for all your Porsche™ specific needs.

AutomobileAtlanta™
505 South Marietta Pkwy, Marietta GA 30060 • 800-792-4944 • Fx: 770-424-6833

Wholesale Parts for All Makes and Models...

For that other car in your garage!

- Best prices
- Same day shipping

Online at [www.AutomobileAtlanta.Com](#), or call 800/792-4944!

9014 KIT

Don't know what to do with your dilapidated old 914 parts car? Now you do. Transform it into a fabulous new 9014.



This 17 piece fiberglass body kit is easily installed in a weekend by a father/son team and requires no bodywork! It completely replaces the front fenders, rear quarter panels, front and rear bumpers and rocker panels—a perfect solution for a rusty or crashed body. The kit will fit as wide as a 9- or 10-inch wheel (see our wheel selection beginning on

page 68) and comes complete with lighting and detailed instructions. Jump on the bandwagon today and save a junked 914!

**Complete 9014 Kit ... [BB9014 \\$2,650.00](#)
9014 Assembly Manual (refundable with kit purchase) ...
BTC 1042 \$16.50**

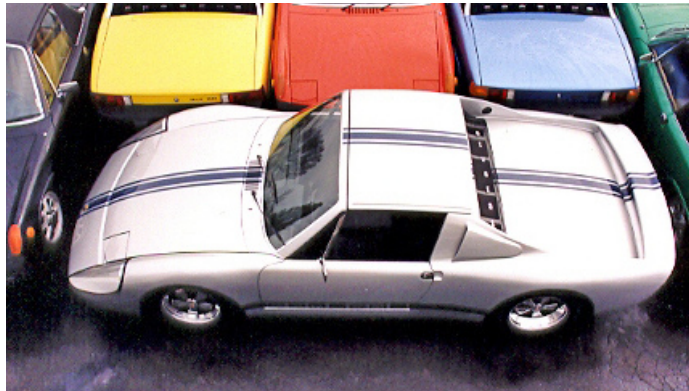

NEED A CHASSIS TO START BUILDING YOUR KIT? CHECK OUT WWW.AUTOATLANTA.COM FOR A 914 YOU CAN SAVE.

Chalon Kit

The Chalon Kit gives your 914 a 911 identity while retaining the classic lines. In addition, you can use 7" and 8" wheels. Easily installed by a competent body shop, the kit includes everything to make your 914 into the 914 of the modern era!



Our Chalon Package Includes:
930 Type Front Bumper
2 Front Turn Signal Assemblies
Box Rocker Panels
2 Rear Turn Signal Assemblies

Rear 911 Type Bumper
2 Rear Quarters
Bumper Bracket Set
1 Rear Bumper Filler Panel
*Update MK 520 incl. 930-s Frt. Bumper, Box Rockers, Nose Kit

**Chalon Package, 930 ... [RMK 500 \\$2,500.00](#)
Updated Chalon, 930-S ... [RMK 520 \\$2,850.00](#)
Instruction Manual ... [RMK 501 \\$16.50](#)**

ELECTRICAL



Relay Board (Rebuilt)

Not often the culprit in fuel injection problems, but a critical item of the 914 electrical system - every engine electrical accessory passes through this board. Core charge \$200.00.

914-4 Relay Board

... [B914 610 104 00](#) \$350.00

914-6 Relay Board

... [B914 610 103 00](#) \$450.00



Relay Board Cover

1970-72 ... [B914 610 111 11](#) \$75.00

1973-76 ... [G914 610 111 13](#) \$56.28



Rebuilt Starter

... [RSR17X](#) \$155.92

Core Charge \$75.00



Rebuilt Alternators

914-4 ... [RAL75X](#) \$104.75

Core Charge \$75.00



914-6 ... [RAL21X](#) \$340.72

Core Charge \$100.00

Voltage Regulator - Screened

Perfect factory Bosch replacement part for all 914 models. Slightly shorter than the original with the latest electronics. Make sure your 914 is charging at 13.6 volts. Any less and you need this new regulator!

Voltage Regulator, Screened, 914-4 ... [R021 903 803 A](#) \$43.45

Voltage Regulator, Screened, 914-6 ... [G043 903 803 B](#) \$106.27

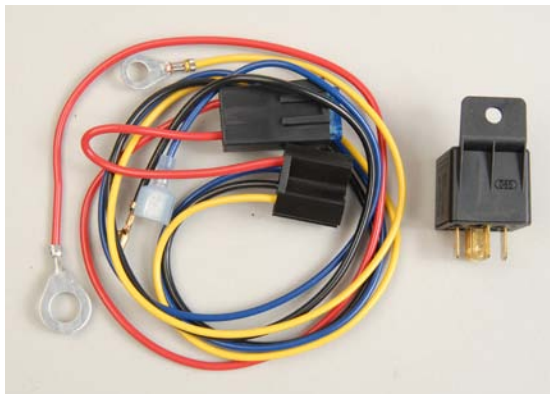

Hot Start Kit

Bosch finally acknowledges that their rebuilt starters leave something to be desired. Now with this Bosch factory hot start kit you can add extra battery voltage to overcome the "clicking" solenoid and non engaging starter. While no substitute for a thorough diagnosis or a bad starter, it is certainly cheap insurance! With instructions!

Hot Start Kit ... [RWR 1](#) \$25.80



Electronic Parts Cleaner: Contact OL

This is the problem solving spray for all of your electrical mysteries! Cleans printed circuit boards, computer components, contact points, relays, engine sensors, and coats contacts to keep them clean. It's even NASA approved. So if you cannot find some strange electrical gremlin, try a can of this electrical cure-all.

Electronic Parts Cleaner
... [RGR 1020 \\$15.95](#)

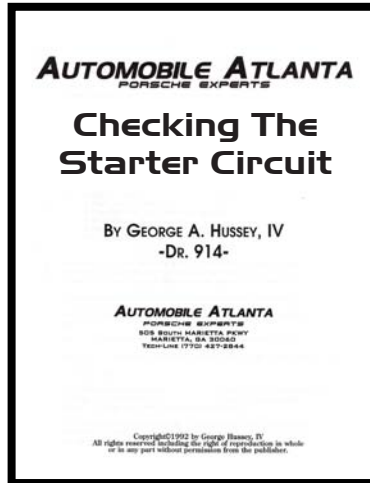

Checking The Starter Circuit

Another handy troubleshooting guide from Dr. 914, this good read can avoid costly starter purchase.

Starter Circuit Pamphlet
... [RTC 1005 \\$11.00](#)



Relays: Black Round, Turn Signal, High/Low Beam, Intermittent Wiper

Thankfully, a 914 is a simple car and uses only a few relays to get the job done.

1. Black Round Relay (fuse power, wipers, cigar, fresh air fan, headlights, horn, driving lights, rear window defrost, fuel injection power, fuel pump, heater blower motor)
8 required ... [R911 615 109 01 \\$27.49](#)
2. Turn Signal Relay ... [R914 618 303 11 \\$40.42](#)
3. High/Low Beam Relay ... [R111 941 583 \\$24.14](#)
4. 1.8 Dual Relay ... [R071 906 059A \\$83.16](#)
5. Intermittent Wiper Relay ... [R477 955 531A \\$70.40](#)
6. 71-73 Buzzer Relay ... [G911 613 125 00 \\$20.75](#)
- 74-75 Seat Belt Interlock Relay ... [G133 919 439 \\$59.92](#)
- 74-Early 75 Buzzer Relay ... G914 615 112 10
- 75-76 \$15.56
- Buzzer Relay ... [G911 613 125 00 \\$20.75](#)



Control Unit Bracket, 914-6

Holds fuel injection computer control unit and mounts to firewall behind passenger seat. By now all of these are rusted away from battery acid so the used parts are harder to find. This part is to be painted semi-gloss black. Order the hardware kit to install.

Control Unit Bracket
... [G914 618 013 10 \\$80.53](#)



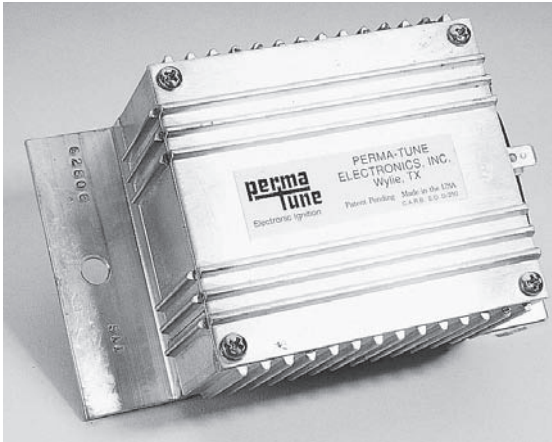

Permatune Ignition Unit

Permatune has long been a favorite alternative to the outrageously priced Bosch electronic ignition control unit. Meticulously assembled Texas, the Permatune outperforms the Bosch unit and at a much lower price. Installation is a direct plug-in. Get the spark back in your life today! Output: 350 volts, 3 amps.

Permatune Ignition Unit, 914/6 1970-72 ... [RPT911 \\$394.53](#)

Fuel Injection Pressure Sensor

Our rebuilt fuel injection components are the highest quality available and replace no longer available parts. Your 914 fuel injection can again operate as it should for snappy performance, great gas mileage, and long engine life. The pressure sensor is notorious for diaphragm failure resulting in a rich mixture, black sooty exhaust, and a poor warm idle. Please evacuate to check this part. If it will not hold vacuum it is bad. Rebuilt by the leading Bosch injection company in the nation you can be assured of a perfect calibration. Purchase the 037 European sensor for extra top end performance along with the factory temperature sensor resistor. CORE CHARGE \$100.00

Rebuilt Pressure Sensor, 1.7 ... [B022 906 051 E \\$275.00](#)

Rebuilt Pressure Sensor, 2.0 ... [B039 906 051 \\$275.00](#)

Rebuilt Euro Pressure Sensor ... [B028 010 0037 \\$395.00](#)

Injector Boot and Injector Lead Repair Kits

These days, if we can find a factory fuel injection harness in any condition it is a miracle. The only alternative is to repair your current one. Injector leads and boots make it as easy as soldering and heat shrinking. Available for both DJetronic (MPC) and LJetronic (AFC), these boots and leads make an undetectable repair.

1. 1.8 2-Pole Injector Lead ... [R553 91265 \\$17.32](#)

2. 1.7, 2.0 4-Pole Injector Lead ... [R553 9125 \\$17.32](#)

3. 1.7, 2.0 2-Pole Injector Lead ... [R553 9123 \\$17.32](#)

4. 1.7, 2.0 3-Pole Injector Lead ... [R553 9124 \\$17.32](#)

5. 4 Pole 1.7, 2.0 Boot ... [B311 906 102C \\$12.00](#)

6. Fuel Pump Boot ... [G311 906 101 \\$18.15](#)

7. 1.8 Injector Boot ... [R022 990 610 2 \\$4.62](#)

8. 2 Pole 1.7, 2.0 Boot ... [B311 906 102A \\$12.00](#)

9. 3 Pole 1.7, 2.0 Boot ... [B311 906 102B \\$12.00](#)

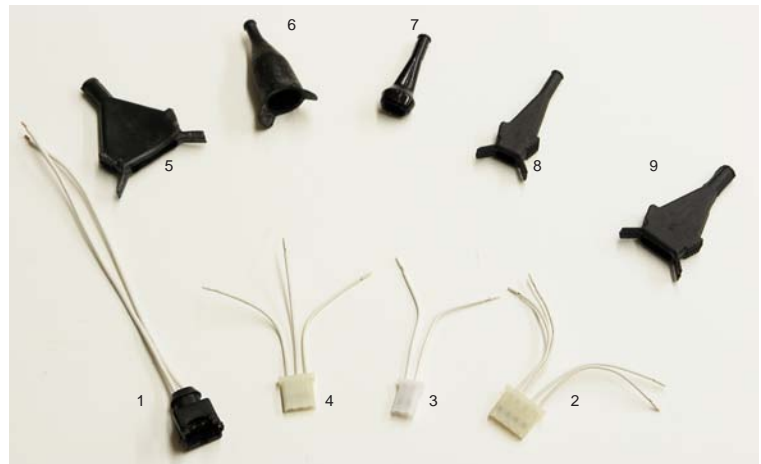

Non Starting Fuel Injection Troubleshooting Procedure

Excellent troubleshooting manual written by Dr. 914. Complete with relay board diagram and flow chart, it'll lead you to the problem.

Non-Starting Procedure ... [BTC1015 \\$11.00](#)

AUTOMOBILE ATLANTA
PORSCHE EXPERTS

Non-Starting Procedure

By GEORGE A. HUSSEY, IV
-DR. 914-

AUTOMOBILE ATLANTA
PORSCHE EXPERTS
808 SOUTH HANCOCK AVENUE
HUNTSVILLE, AL 35894
YELL-LINE 177-0743-2844

Copyright©1992 by George Hussey, IV
All rights reserved including the right of reproduction in whole
or in any part without permission from the publisher.

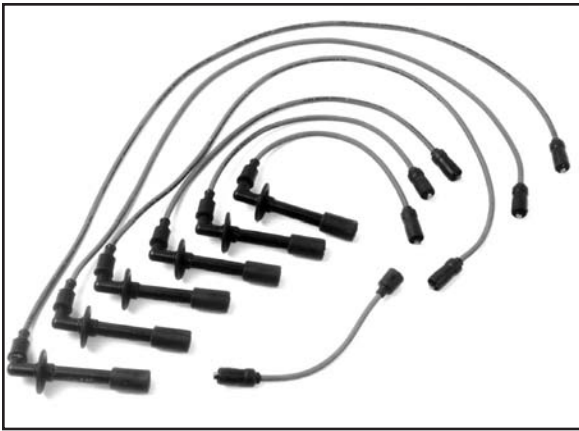

914-6 Custom Wire Sets

These custom made wire sets with German made connectors are the finest money can buy. Custom fit for long life and best performance. Limited lifetime warranty!

914-6 Wire Set ... [R911 609 061 00 \\$113.19](#)



Crane Electronic Ignition 12 Volt - For 914-4 or 914-6, Eliminates the Points!

Replaces any contact points ignition. Upgrades existing factory-installed electronic ignition. Breakerless ignition keeps engine always in tune and engine at peak efficiency for better gas mileage. Ensures faster, easier starts in all temperature extremes (operating temperature is -65F to +350F). Improves power for smoother running. Ends points problems forever, saving on replacement costs. No more timing adjustments - just set timing once and forget it for the life of your vehicle's engine. Timing is accurate to within an incredible 1/10 of a degree. Solid-state power module ensures consistent, high firing (up to 7,000 RPM) to dramatically increase spark plug life. Dwell is preset at factory for installation - only 4 wires to hook up. CARB EO #D-47-2, 3 and D-225-11. Hardware and instructions included.

Crane Electronic Ignition ... [RXR710 \\$159.50](#)

Tune-up/Service Kit For Bosch Distributors, 914-6

Consists of the parts necessary for a complete and professional tuneup! Air filter, oil filter, spark plugs (the expensive W4DPO variety), valve cover service kit, distributor cap, rev limiting rotor, fuel filter, ignition points and alternator belt.

914-6 Tune-Up Kit for Bosch Distributors ... [BMS6 \\$175.45](#)



Pertronix Ignitor Electronic Ignition

Never change or adjust points again! Breakerless ignition system with hall-effect magnetic trigger system. Fits entirely inside distributor for a stock appearance.

Pertronix Ignitor Electronic Ignition ... [RPER1847V \\$98.45](#)

Pertronix Ignitor Electronic Ignition for Carbureted Engines

... [RPER1847 \\$98.45](#)

So easy to install that your girlfriend could do it!



ELECTRICAL

.009 Distributor With Full Centrifugal Advance

The .009 distributor is a must for carburetion, as its centrifugal advance provides faster acceleration. It comes complete with points, condenser, distributor cap, and is easy to install.

.009 Distributor ... [R0 231 178 009 \\$92.50](#)

Trigger Points

If your fuel-injected 914 misses upon heavy acceleration, misses on diagonal cylinders, or idles roughly, trigger points could be the culprit. Easily installed with the distributor removed. For 1.7 and 2.0 engines.

Trigger Points

... [R311 905 301 \\$155.05](#)

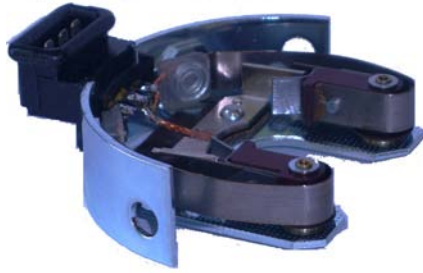

Custom Wire Sets

These custom made wire sets with German made connectors are the finest money can buy. Each one is custom fit for the particular engine and guaranteed to provide long life and the best performance. Limited lifetime guarantee!

1.7, 1.8 Wire Set ... [R021 998 031 A \\$35.14](#)

2.0 Wire Set (not pictured) ... [R616 109 952 10 \\$36.85](#)



Bosch Blue Ignition Coil

The Bosch blue is the latest coil improvement and provides a hotter spark to increase combustion, power while dressing up your engine compartment with its bright blue color.

Bosch Blue Ignition Coil

... [R043 905 115C \\$41.25](#)

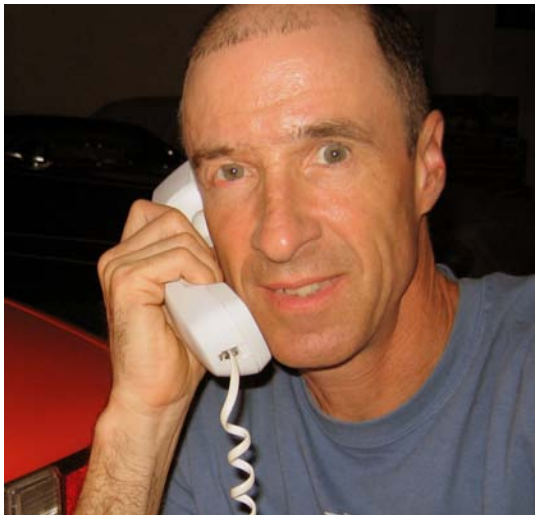

GREAT TECH ADVICE!

For 24-hour assistance and for all of you Florida folks, call our representative Steve Gaglione. A long-standing member in a leadership position with the PCA, Steve really knows his stuff, plus he's a great guy!

(813) 978-3433

Maintenance Items Chart

Tune Up	
Description	Part Number
Points	059 998 051 B
Distributor Plate	900 905 227 C
Distributor "O" Ring	111 905 261
Regular Rotor	043 905 225
Rev. Limiting Rotor (keeps engine from revving)	022 905 225 A
Dist. Cap	113 905 207 C
1.7, 2.0 Condensor	311 905 295 C
1.8 Condensor	311 905 295 B
Coil (Bosch Blue)	022 905 155 B
Spark Plug Ends Short	113 035 255 A
Spark Plug Ends Long	021 035 255
Spark Plugs 1.7	N1 781 119
Spark Plugs 1.8 & 2.0	N1 781 114
Spark Plug Boots	111 905 449 A
Spark Plug Wire Set 1.7 & 2.0	021 998 031
Spark Plug Wire Set 1.8	039 198 031
Valve Adjustment	
Description	Part Number
Valve Cover Gaskets	021 101 481
Valve Adj. Lugs 70-73	022 109 451
Valve Adj. Lugs 74-76	043 109 451
Valve Adj. Lugs 73 2.0	039 109 451
Valve Adj. Nuts 70-73	N 011 152 2
Valve Adj. Nut 74 -76	028 109 453
Pushrod Tube Seals Small (16 req'd)	021 109 345 A
Pushrod Tube Seals Large (16 req'd)	021 109 349 B
Valve Adj. Feeler Gauge .006 for 1.7, 1.8, 2.0	022 905 155 B
Spark Plug Ends Short	113 035 255 A
Spark Plug Ends Long	021 035 255
Spark Plugs 1.7	N1 781 119
Spark Plugs 1.8 & 2.0	N1 781 114
Spark Plug Boots	111 905 449 A
Spark Plug Wire Set 1.7 & 2.0	021 998 031
Spark Plug Wire Set 1.8	039 198 031
Belt Change	
Description	Part Number
Alternator Belt	021 903 137 A
DPD Air Cond. Belt	ZVW 234 221
VPC Air Cond. Belt	ZVW 800 2284
Air Pump Belt	039 161 615
Filter Change	
Description	Part Number
1.7 Air Filter	022 129 620
1.8, 2.0 Air Filter	021 129 620
Air Pump Filter	133 131 123
Fuel Filter 74	039 161 615
Fuel Filter 75-76	133 133 511
Oil Filter	021 115 351 A
Strainer Kit	021 198 031
Strainer Basket	021 115 175
Oil Cap Seals Round (1.8 liter only) 2 req'd	022 115 331
Oil Cap Seals Flat (1.8 liter only) 2 req'd	022 115 315
Oil Filter Base Gasket	021 115 487

Wipers/Lighting	
Description	Part Number
Wiper Blade Each	914 628 311 10
Wiper Arm - Left	914 628 313 10
Wiper Arm - Right	914 628 314 10
Headlights (each)	111 941 261 B
Turn Signal Bulb	N 017 738 2
Pkg. Light Bulb	N 017 738 2
Side Marker Bulb	N 017 717 2
Backup Light Bulb	N 017 732 2
Small Instrument Bulb	900 631 132 90
Large Instrument Bulb	900 631 102 90
Factory Tool Kit	111 012 021 B
Factory Jack	914 721 011 10
Factory Owners Manual (State year)	
Embossed 914 Owners Manual Cover	GWWM 390 100
Interior Light Bulb	N 017 723 2
914 Tech Specs	WKD 422 221
Hayes Manual	RBK 7072
Clymer Manual	RBK 7071
Factory Manual Set	WKD 480 921
Tech Tips 700	BBK 7074
Forever Black	RGR 5013

Don't Forget These!

See our selection of VIN and Engine stickers on pages 160-161!



ELECTRICAL

914-4 Distributor Parts

1. Condenser 1.7, 2.0 ... [R311 905 295 C \\$7.50](#)
- Condenser 1.8 ... [R021 905 295A \\$9.97](#)
2. Points Plate with Points ... [R311 905 227C \\$75.00](#)
3. Points ... [R311 998 063 \\$11.75](#)
4. Distributor Clip ... [R111 905 265 \\$4.16](#)
5. Distributor Cap ... [R113 905 207C \\$7.64](#)
6. Rev. Limiting Rotor ... [R022 905 225 A \\$25.97](#)
7. Non Rev. Limiting Rotor ... [R043 905 225 \\$4.95](#)
8. Distributor Screw ... [GN 107 032 \\$1.51](#)
9. Distributor O-Ring ... [R111 905 261 \\$2.74](#)
10. 1.7 Vacuum Advance ... [R07 085 \\$195.75](#)
- 1.8 Vacuum Advance ... [G039 905 271 \\$193.20](#)
- 2.0 Vacuum Advance ... [G123 712 1981 \\$195.75](#)
11. Trigger Points 1.7, 2.0 ... [R311 905 301 \\$155.05](#)

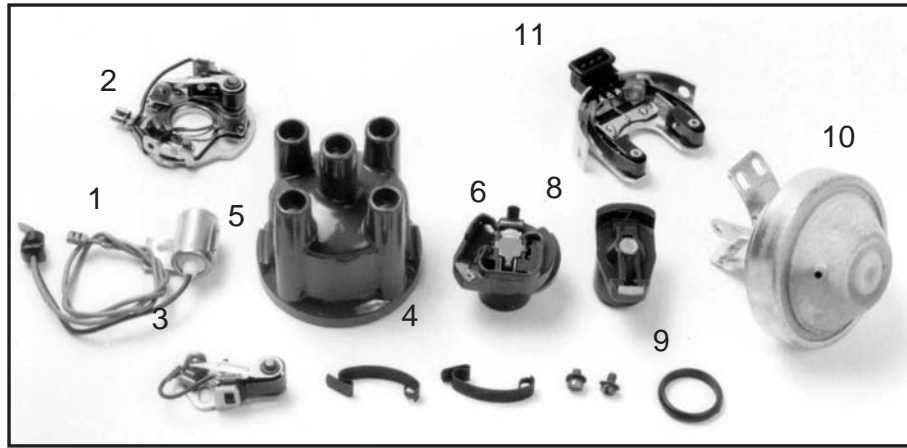

Bosch Distributor Lube

A squeaking distributor? The point gap constantly changing? You forgot to lubricate the distributor cam! Official Bosch grease for Bosch points and trigger points. A must for ignition reliability. A generous tube which no tool box should be without.

Bosch Distributor Lube ... [R570 000 2005 \\$7.98](#)



Major Service Kit 914-4

Our Major Service Kit consists of everything we use when performing a thorough 914 major service. Don't be caught short of parts when you do yours!

914-4 Major Service Kit ... [BMS4 \\$77.00](#)

Our Kits Include: 914-4 Kit:

Air Filter 1973-76
Fuel Filter
Oil Filter
Strainer Kit
Alternator Belt
Spark Plugs
Points

Distributor Cap
Distributor Rotor
Valve Cover Gasket Kit
Oil Cap Seals (1.8)
Distributor O-ring
Condenser
Oil Drain Plug Washer



Diecast Model, 1:18 Scale

Beautifully crafted Porsche 914 diecast model. Highly detailed and realistic. By Revell. Available in Blue or Yellow - specify color.

Porsche 914, 1:18 Scale Model
... [RREV2001 \\$49.45](#)



THE OPTIMA BATTERY

The Optima Battery looks like no other, and performs like no other as well! Some exclusive features of this battery include over 15 times the vibration resistance of other batteries and up to 2 times longer life. Spill-proof and maintenance-free, it installs in almost any position. Custom fit for all 914-4 models.

Optima Battery ... [ROP5636 \\$149.95](#)



Perfect for 914 battery area preservation!



Spark Plug Towers & Spark Plug Wire Clips

Loose or broken spark plug towers cause the strange ignition miss you can never find. Easy screw in replacements, order 2 or 3 wire clips. Keep the wires neat and the holes in sheet metal plugged!

1. 914-6 ... [G901 609 309 00 \\$50.50](#)
2. 914-4 1.8, 1.7 Long ... [G021 035 255 \\$10.09](#)
3. 914-4 2.0, 1.7, 1.8 Short ... [G113 035 255 A \\$10.84](#)
4. 2-Wire Clip ... [G113 995 451A \\$4.84](#)
5. 1-Wire Clip ... [G111 201 261 \\$12.50](#)



Battery Tray Saver

This pad has been infused with a special mix of chemicals to counter the effects of the inevitable battery acid spill on the battery tray. A fresh tray saver every year will assure you will never need to replace the battery tray. This high-tech cleaner and preservative will clean dirty and corroded terminals, turn color when acid is detected, and the special coating will continue to keep them clean! Note: If you have an intermittent starting problem that you cannot locate, it could be a corroded battery terminal!

Battery Mat ... [RGR 5010 \\$10.97](#)

Battery Cleaner (Dissolves and detects acid) ... [RGR 5011 \\$9.82](#)

Battery Quick Disconnect Switch

Disconnecting your battery is the best way to preserve it when your Porsche is stored. A simple twist of a knob and current no longer flows. This item is great for poor quality positive harnesses. The switch is also simple, inexpensive theft protection.

Battery Disconnect Switch ... [RTL 1044 \\$21.95](#)



Ground Strap For Battery

Nice reproduction - super heavy duty!

914, 1970-73 Battery Ground Strap ... [B914 611 903 10 \\$24.20](#)



ELECTRICAL

Battery Grounding Kit

Tired of your Porsche turning over slowly after a little highway jaunt or an inadequate charging rate? This might be caused by weak factory grounds. Original equipment grounds were never heavy duty. Automobile Atlanta saves the day with our heavy duty, perfectly reproduced, ground kit with super conductive copper/brass terminals. You may once again enjoy hot weather driving.

Battery Grounding Kit ... [BTG9141 \\$22.00](#)



Fuse Box Cover

Often missing from the 914 as too many left knees have knocked and broken it, this more pliable reproduction is a perfect fit!

Fuse Box Cover

... [B914 612 316 10 \\$29.50](#)

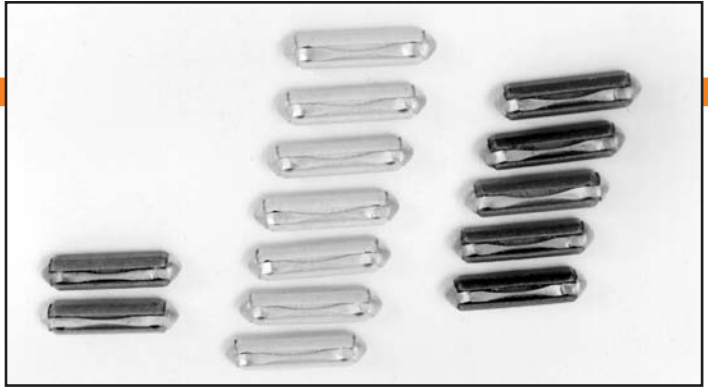
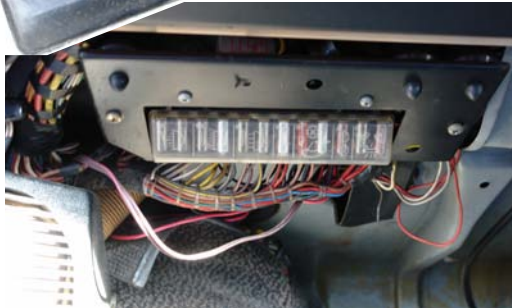

Fuses

FOR ALL 914 FUSE NEEDS. Our fuse assortment has several of every fuse size for your 914, comes in a handy bag and is complete with an installation schematic. A must for the glove box!

Fuse Assortment ... [BAA 067 \\$3.50](#)

Battery Clamp and Bolt

Wonder why your battery flops around when cornering? You forgot to fasten it down! Factory equipped with a strong clamp, the 914 battery tray was also reinforced with this necessary item. This is a good reproduction at half the price of the genuine.

Clamp and Bolt

... [B914 611 233 10 \\$8.25](#)



Bosch Racing Cutoff Switch

This is the same one you see on the factory racing Porsches. Original Bosch two-pole battery cut-off switch has a removable key that can also be an inexpensive theft deterrent!

Bosch Racing Cutoff Switch

... [R034 100 1001 \\$46.14](#)



Battery Covers

Whether a Concours buff or a driver, we have the battery cover to protect this vulnerable area from an acid spill. Smaller waffle pattern is original equipment, while larger smooth is part of the factory "HO" Campaign.

1. HO Battery Cover

... [G281 915 411 \\$25.00](#)

2. Original Battery Cover

... [G914 611 116 00 \\$31.85](#)



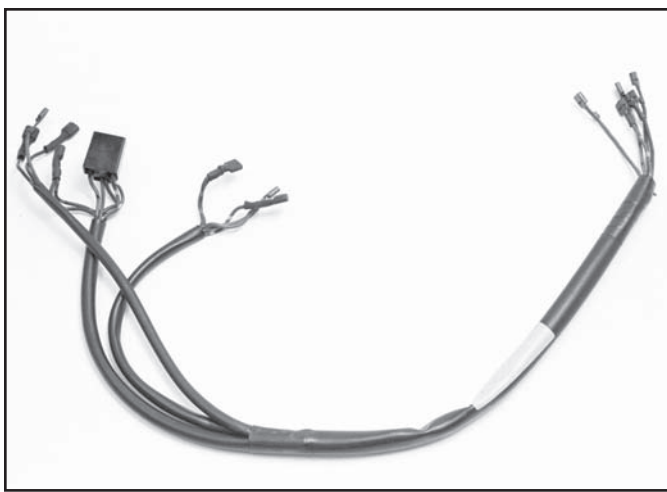

Console Wiring Harness and Schematic

Everyone installing a factory or reproduction center console needs an auxiliary wiring harness to connect the gauges. This factory harness has the exact color coding and the right connections for easy installation.

Console Wiring Harness (Includes Schematic) ... [G914 612 151 10 \\$34.56](#)
Schematic Only ... [RTL 1050 \\$5.00](#)

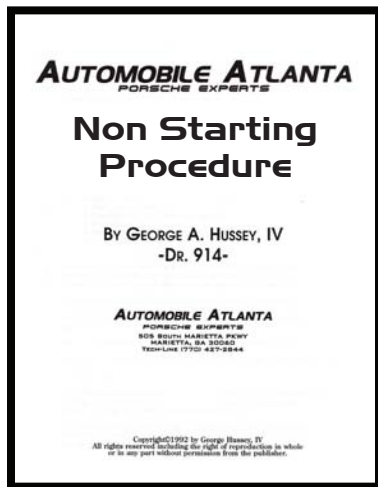

Non Starting Fuel Injection Troubleshooting Procedure

The best troubleshooting pamphlet for a 914 in the market. Personally written by Dr. 914 and based on his years of troubleshooting experience, it will instantly lead you to the problem. Complete with a relay board schematic and an easy to follow flow chart. Read this and you will be an expert in no time!

Non Starting Fuel Injection Troubleshooting Procedure; 914 1970-76 ... [BTC1015 \\$11.00](#)

Battery Tray Saver

This pad has been infused with a special mix of chemicals to counter the effects of the inevitable battery acid spill on the battery tray. A fresh tray saver every year will assure you will never need to replace the battery tray. This high-tech cleaner and preservative will clean dirty and corroded terminals, turn color when acid is detected, and the special coating will continue to keep them clean! Note: If you have an intermittent starting problem that you cannot locate, it could be a corroded battery terminal!

Battery Mat ... [RGR 5010 \\$10.97](#)

Battery Cleaner (Dissolves and detects acid) ... [RGR 5011 \\$9.82](#)



Battery Tray Sealant

Battery trays are prone to collect battery acid and rust. This product will eliminate of the problem once and for all! Clear, indestructible battery area sealant maintains concours perfection while providing lasting protection against acid and rust damage. We have sprayed this on the trays for years and the stuff just will not come off!! A truly great product. Easily painted over in the cars color. Add a battery mat and battery top and you are in business!

indestructible battery area sealant maintains concours perfection while providing lasting protection against acid and rust damage. We have sprayed this on the trays for years and the stuff just will not come off!! A truly great product. Easily painted over in the cars color. Add a battery mat and battery top and you are in business!

Battery Tray Sealant ... [RGR5018 \\$11.55](#)



Factory Dash Bezels

Freshen your worn switch bezels with these factory new ones. Available are headlight, driving light, cigar lighter and emergency flasher and rear window defogger.

Headlight Switch Bezel ... [G113 941 543B \\$12.50](#)

Fog Light Bezel 70-72 (original green) ... [G113 941 543E \\$34.70](#)

Fog Light Bezel 73-76 ... [R111 941 543H \\$32.39](#)

Emergency Flasher Bezel (USA) ... [G113 941 543E \\$34.70](#)

Cigarette Bezel ... [G343 941 543 \\$9.50](#)

Rear Window Defrost Cap w/Symbol ... [G411 941 543C \\$34.70](#)

Please note the difference between your originals and the bezels pictured above.

ELECTRICAL

Genuine Porsche Flashlight

The Genuine Porsche Flashlight comes with many features such as LED charge Indicator, Reflector And Fold-out magnifying glass for reading maps. Fully charged, the lamp can be used for 40 minutes. This rechargeable flashlight can be plugged into any 12-volt Porsche cigarette lighter receptacle.

Genuine Porsche Flashlight GWAP05014115 \$78.18



1970-71 Wiper Washer Switch and Parts

A very hard to find part because of its limited production, the 1970-71 wiper switch was dash mounted by the factory and used a unique bezel. These parts are again available factory fresh and reasonably priced.

1. Wiper Switch Bezel ... [G914 613 428 10 \\$14.50](#)
2. Wiper Knob ... [G914 613 425 10 \\$13.72](#)
3. Wiper Switch ... [G141 955 517A \\$48.72](#)

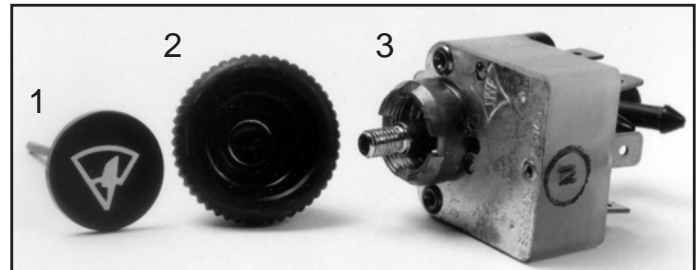

Combined Start & Ignition Switch, 914-6

Plastic electrical switch that fits behind the tumbler and key. Easily installed.

Combined Start And Ignition Switch, 914-6
... [R911 613 017 01 \\$39.95](#)



Dual Sending Unit - Works Gauge & Light!

The oil pressure sending unit is a must for 914-6 high performance applications where oil pressure monitoring is critical. Works both the gauge and the warning light.

Sending Unit
... [RVDO 360 023 \\$43.95](#)

Oil Temp Sending Unit

When adding a temperature gauge, this handy kit will make installation simple! Your engine block is already machined for direct bolt-in, and the sending unit is matched to your engine's operating temperature.



Sending Unit Cover
... [G039 101 267 \\$74.12](#)
Sending Unit for Factory Gauge
... [G039 919 268 \\$57.04](#)
Sending Unit for Aftermarket VDO Gauge ... [RVDO 323 055 \\$17.32](#)
Cover Seal ... [R021 101 269A \\$6.88](#)



Dual Relay 1.8
... [G071 906 059A \\$123.22](#)



Relays

1. Black Round Relay (fuse power, wipers, cigar, fresh air fan, headlights, horn, driving lights, rear window defrost, fuel injection power, fuel pump, heater blower motor) 8 required ... [R911 615 109 01 \\$27.49](#)
2. Turn Signal Relay ... [R914 618 303 11 \\$40.42](#)
3. High/Low Beam Relay ... [R111 941 583 \\$24.14](#)
- 1.8 Dual Relay ... [R071 906 059A \\$83.16](#)
4. Intermittent Wiper Relay ... [R477 955 531A \\$70.40](#)
- 71-73 Buzzer Relay ... [G911 613 125 00 \\$20.75](#)
- 74-75 Seat Belt Interlock Relay ... [G133 919 439 \\$59.92](#)
- 74-Early 75 Buzzer Relay ... [G914 615 112 10 \\$15.56](#)
- Buzzer Relay ... [G911 613 125 00 \\$20.75](#)



VDO Oil Pressure Hose Kit

The oil pressure sending kit consists of everything you need to install the dual (gauge and warning light) sending unit on your Porsche engine. This unit is a must for high performance applications where oil pressure monitoring is critical

Oil Pressure Hose Kit ... [VDO150 752 \\$37.95](#)

Hella Replacement Set

Very much like the factory original 914 horns also made by Hella, this horn set is a direct bolt into your 914.

Hella Factory Look Horn ... [RHH 6008 \\$49.50](#)



Hella Twin Tone Horn

These are the perfect addition to your auto. Let them know they are about to make a huge mistake denting your fender! The melodious twin-tone warning has a very wide spread alerting sound that is sure to wake them up!

Hella Twin Tone Horn ... [RHH 6007 \\$29.99](#)



Combined Starter Ignition Switch, 1970-71 With Wire Leads

Not so easily installed but a dire necessity when failed, this metal electrical ignition switch comes complete with its wire pigtail and must be soldered onto the old connection pins and then plugged into the main wiring harness. Butt connectors are butchery!

Combined Starter Ignition Switch, 1970-71 With Wire Leads
... [R311 905 865A \\$40.42](#)



Replacement Key and Cylinder

This is an exact reproduction of the aftermarket cylinder with key, but with a different key shaft. Inexpensive replacement for the factory part.

Replacement Key and Cylinder, 1970-71 ... [G914 347 903 00 \\$89.50](#)

Replacement Key and Cylinder, 1972-76 ... [R477 905 855C \\$51.98](#)

We can rebuild your original cylinder!

Turn Signal Switch 70-71

... [R914 613 927 12 \\$65.98](#)

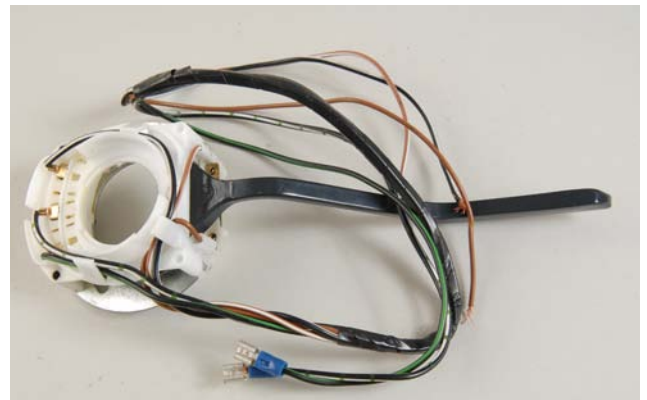

Steering Column Wheel/Ball Bearing

Also part of the horn repair kit. Everything you need for the repair of the expensive horn butterfly. Fits 72-76 914 models. When the steering wheel starts to have up and down movement, this bearing has failed. Easily replaced. Comes with plastic insert for smooth quiet operation.

Steering Column Wheel/Ball Bearing

... [G911 347 771 02 \\$43.27](#)

ELECTRICAL

Electric Washer Kit

Fabulous factory windshield washing is now available! Using all SWF parts, we have brought you a reliable system that will not run your spare tire flat!

Electric Washer Kit ... [B 914 EW \\$245.00](#)

Consists of: Washer Switch, R111 953 519G (\$156.00) and Washer Pump, R823 955 651 (\$39.95)

Washer Kit Installation Instructions (included with kit) ... [RTL 1055 \\$2.00](#)

Washer Pump Mounts (optional - 2 required) ... [G914 628 741 00 \\$7.37](#)



Windshield Washer Nozzles

More of an appearance item than us wanting them to function these days, these parts are a "must replace" after painting. New nozzles really dress up the cowl.

1. 1970-early 1974 Chrome ... [G901 628 741 01 \\$14.24](#)

2. 1974.5-1976 Black ... [G914 628 203 11 \\$7.37](#)



3. Wiper Blade, Bosch or SWF ... [R964 628 901 02 \\$10.99](#)

4. Wiper Caps ... [G901 628 926 00 \\$5.91](#)

5. Wiper Nut ... [G901 628 341 00 \\$8.75](#)

Wiper Arm, Right ... [G914 628 314 10 \\$40.42](#)

Wiper Arm, Left ... [R914 628 313 10 \\$40.42](#)



Washer Hose

This hose keeps the water directed to the windshield and not on your lap! Correct German stuff! Order six feet to replumb the complete system. State length - price is per foot.

Washer Hose ... [R914 628 901 10 \\$3.46/foot](#)

Turn Signal and Wiper Switches

Windshield wiper switch for all 1972-76 914 models. Easily installed once the steering wheel and lower dash pad is removed, remove the four screws, the two electrical plugs and remove the two switches as one. Please remember to save the white wire channel from your old switch as the new switch has an extra wire for an added washer pump.

Windshield Washer Wiper Switch, 914 1972-76 ... [R914 613 915 14 \\$175.00](#)

Turn Signal Switch, 914 1972-76 ... [R914 613 913 14 \\$125.00](#)



Electric Windshield Washer Pump

Electric washer pump for all of the above captioned models. These fail from lack of use and the fluid therefore crystallizing. The hose fittings also get brittle. Order new hosing and fittings and a washer bottle cap while you are at it.

Electric Windshield Washer Pump ... [R823 955 651 \\$39.95](#)

Washer Pump Mounts ... [G914 628 741 00 \\$7.37/each](#)

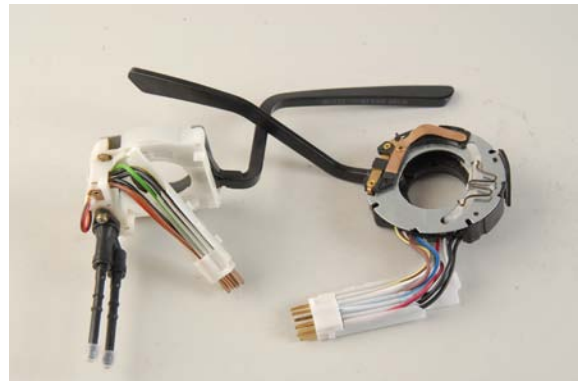

Bosch/Hella H-4 Headlamp Conversion For Bright White Light

The H-4 headlamp conversion is the best thing you can do for your lighting! Bright white light illuminates much further than stock headlamps, showing you the WHOLE roadway. H-4's bolt directly in place of your headlamps. Optional 100 watt bulbs are the ultimate. Note: H-4's are a must for us near-sighted drivers!

Hella H-4 Conversion ... [R70476 \\$98.75](#)

Bosch H-4 Conversion ... [R030 1600 118 \\$92.40](#)

Optional 100w Highbeam Bulb ... [R914 631 106 H4 \\$17.32](#)



See where you are going!



Pair, Z-Beam H4 7 Inch Round Headlights

The H-4 headlamp conversion is the best thing you can do for your lighting! Bright white light illuminates much further than stock headlamps, showing you the WHOLE roadway. H-4's bolt directly in place of your headlamps. Optional 100 watt bulbs are the ultimate. Note: H-4's are a must for us near-sighted drivers!

Z-Beam Pair ... [RNEO 910C \\$60.50](#)



Reproduction Driving Lights

Tired of not being able to see in the dark while driving your 914? The answer is to replace those old foglights with these PILOT halogen driving lights. Very easy to install and you can use the existing wiring and switch. You can also use the original foglight brackets if you have them or the stainless steel brackets that are included with this kit.

Pair of Driving Lights With Stainless Brackets

... [B914 631 163 00 \\$89.95](#)

Factory Look-Alike Driving Lights For '75-76 914

If your 1975-76 914 came without driving lights, try these! With slight bracket modification, they fit in the stock position and you cannot tell them from the very expensive factory set. Our kit comes with bulbs!

1975-76 Style Driving Lights ... [R23625 \\$109.72](#)

Optional 100W Bulb ... [G928H3100 \\$6.00](#)



1975-76 Driving Lights

Rare factory replacements we found in an old warehouse. Heavy steel, with chrome plated rim, use them to restore your Concours entry or add to your non-equipped car! Sold with their own wiring harness, simply plug them into the main harness in the trunk, add a switch and relay, and bright light is yours!

Driving Lights ... [G914 631 131 10 SPECIAL! \\$195.00!](#)

ELECTRICAL

TAIL LIGHT LENSES

We offer the remaining Hella originals as well as our AutoAtlanta reproduction lenses in USA (red and clear), European (Amber, Red and Clear) and Italian (all Clear) versions.

Rear Left USA ... [B914 631 939 11 \\$125.00](#)

Rear Right USA ... [B914 631 940 11 \\$135.00](#)

Left European ... [B914 631 949 10 \\$125.00](#)

Right European ... [B914 631 950 10 \\$135.00](#)

Italian Left ... [B914 631 947 12 \\$125.00](#)

Italian Right ... [B914 631 948 12 \\$125.00](#)

Left European, Hella ... [R914 631 949 10 \\$239.80](#)

Right European, Hella ... [R914 631 950 10 \\$243.20](#)



Buy a set and save! Your choice, only \$225.00

Front Turn Signal Lenses & Bucket

Colorfully decorate your car and make a nighttime statement with beautiful new lenses. A nice finishing touch for Concours buff's.

1. European - Dark Amber/White ... [B914 631 937 10 \\$29.50/each](#)

2. Italian - Clear ... [B914 631 936 12 \\$65.00/set of two](#)

3. USA - All Amber ... [B914 631 934 11 \\$24.75/each](#)

4. Turn Signal Seal ... [B914 631 957 10 \\$11.00/each](#)

Make your front parking lights and turn signals shine with these brand new original equipment turn signal buckets. Highly chromed, these brand new units are quite a complement to turn signal.

5. Turn Signal Bucket ... [G914 631 401 11 A \\$209.72](#)

6. Turn Signal Seal, Factory ... [G914 631 957 10 \\$48.18](#)

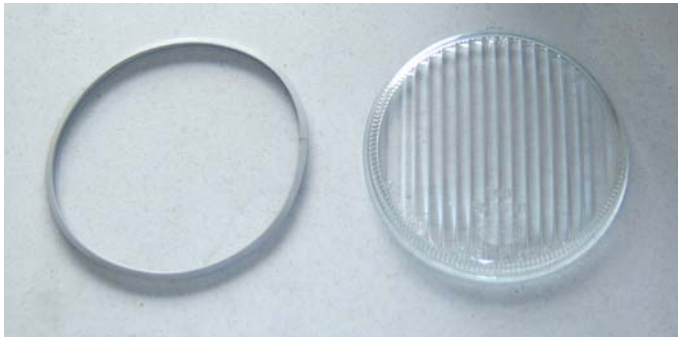

Foglight Lens and Gasket

Gasket for Foglamp ... [B914 631 914 10 \\$13.20](#)

Foglamp Lens, White, USA ... [G914 631 913 11 \\$43.13](#)

Headlight Brush Strip, '70-72

You concours types MUST not be without them! If you look at the back of your headlight box (all of you 70-72 owners) you will find the brush strip in nasty condition! How could the concours judges have overlooked this? Well, they didn't, just knew that the factory had long discontinued them. Well, thank goodness for new old stock. Again, a perfect brand new part for a perfect price. Don't be without them! Buy a set and save!



4

5

6

Headlight Brush Strip, '70-72 ... [G914 750 079 10 \\$27.34 Set of Two, \\$50.00](#)

770-427-2844 or 800-792-4944



Sidemarker Lenses

Beautiful round factory side marker lens for all USA delivered 914 models. Comes complete with screws.

Sidemarker Lens, Amber, Left

... [G914 631 945 00 \\$39.50](#)

Sidemarker Lens, Amber, Right

G914 631 946 00 \$39.50

Sidemarker Lens, Clear

... [R914 631 000 00 \\$49.50/pair](#)

Gasket for Sidemarker Lens

... [B914 631 405 06 \\$8.80/each](#)



Cibie Oscar Plus Driving Lights

Original style driving lights for the Porsche rally cars. These lights were originally mounted on the hood or in front of the bumper on Porsche rally cars. These lights give a great authentic look to your rally or GT car. Sold as a pair, specify clear or amber color. Housing is black or chrome. Lights measure 180mm wide, 215mm high, 88mm deep.

Pair of Cibie Oscar Plus ... [RTA 6459 \\$330.00](#)



Cibie Tango Driving Lights

Original style driving lights for the Porsche rally cars. These lights were originally mounted on the hood or in front of the bumper on Porsche rally cars. These lights give a great authentic look to your rally or GT car. Sold as a pair, specify clear or amber color. Housing is black or chrome. Lights measure 123mm wide, 150mm high, 52mm deep.

Pair of Cibie Oscar Plus ... [RTA 6457 \\$330.00](#)



3-Hole Pivot Pin Inner Support

For all headlamp housings.

... [G914 750 166 10 \\$26.36](#)



Factory Driving Light Bulbs

... [R900 631 130 90 \\$13.86](#)



H-3 Halogen Replacement Bulbs

For driving lights, 1975-76.

H-3, 12 volt, 55 watt 75,76 Driving Lights

... [R64151 \\$9.82](#)

H-3, 12 volt, 100 watt

... [R64153 \\$12.13](#)

H-4 Halogen Replacement Bulbs for Main Beams

Need to replace a bulb for a headlight, driving, or foglight? We have all replacement in stock for immediate shipping. Don't be caught in the dark.

H-4, 12 volt, 55/60 watt Opt.

Headlights ... [R64193 \\$12.13](#)



New Blue Ion Bulbs

Have you seen a new car with blue headlights? Get that same high tech look with a blue ion bulb. People will really pay attention and accidents will be reduced! Who wants a bashed 914?

H-4 Blue Ion Bulb, 80 watt ... [RBB 80 \\$22.52](#)

H-4 Blue Ion Bulb, 100 watt ... [RBB 100 \\$22.52](#)

H-3 Blue Ion Bulb, 100 watt ... [RBH 100 \\$22.52](#)



ELECTRICAL

Amber/White European Turn Signal Lenses

Special buy from Hella! Beautiful factory look lenses in the European variety. What an improvement colorful lenses can make.

Amber/White European Turn Signal Lenses

... [B914 631 937 10 \\$55.00/set of Two](#)



Rear License Plate Lights

Rectangular 1970-74 style and triangular 1975-76 model, these lights are often neglected until the cops stop you! Check yours today and remember, when connecting, brown is ground and connects to the body of the light.

1. One-Piece 70-74 Light ... [G914 631 601 00 \\$27.81](#)
2. 75-76 License Plate Light Body ... [G911 631 620 AA \\$6.05](#)
3. 75-76 License Plate Light Gasket ... [G911 631 608 00 \\$2.29](#)
4. 75-7 License Plate Light Lens ... [G911 631 606 00 \\$16.72](#)



REMEMBER THAT BROWN IS GROUND AND CONNECTED TO THE BODY OF THE LICENSE PLATE ASSEMBLY. IF YOU MIS-CONNECT THE WIRES, YOU WILL BURN OUT THE WIRING HARNESS.

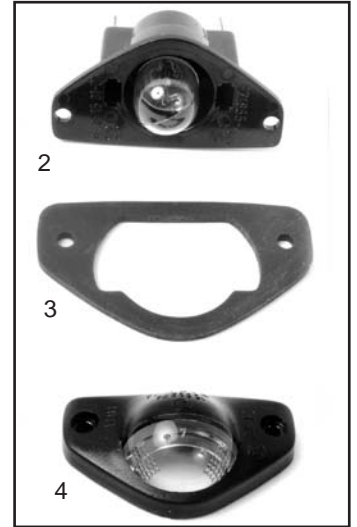

Taillight Lens Seal

Set of Two. ... [B914 631 939 00 \\$16.50](#)



Interior Light Bulb

... [G900 631 106 90 \\$2.25](#)

License Plate Light

1. 70-74 License Plate Light ... [G900 631 103 90 \\$3.89](#)
2. 75-76 License Plate Light ... [G900 631 104 90 \\$2.20](#)



Euro Turn Signal Kit

The original Euro front turn signal kit. This is the light kit that has been sold around the world to hundreds of satisfied 914 owners. If you already have the Euro front lenses then why not make them function like they were meant to? Easy to follow instructions are included.

Euro Turn Signal Kit ... [B914 6438 \\$33.00](#)



Rear Update Kit

Achieve the look of the 911 rear update and play fill in the void with this highly reflective lens. Made exclusively for the 914 and originally installed as a dealer option, order it with either manual cable release or wired electric release. Easy installation.

Rear Update Kit Manual ... [RZP 9142 \\$150.00](#)

Rear Update Kit Electric ... [RZP 9141 \\$175.00](#)



Bulb Kit

Great item! At least ten bulbs and one of every bulb in the exterior of your car and some for the instruments. A great value.

Bulb Kit ... [BAA200 \\$11.00](#)

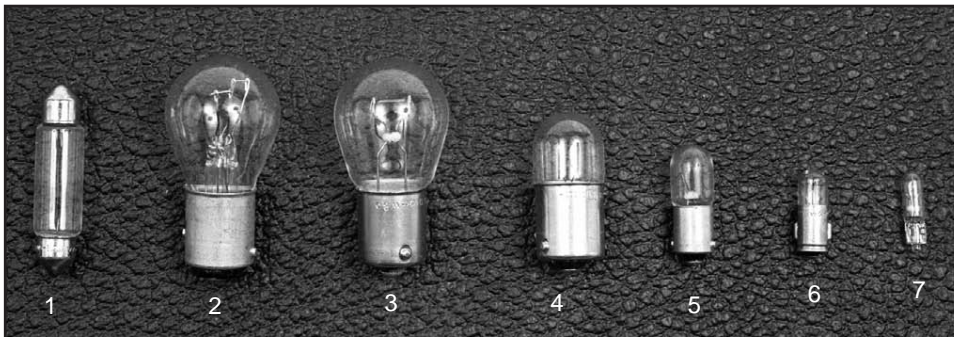

Replacement Bulbs

Always have replacement ones available to keep the cops off your back!

1. Interior Light 12V 10W ... [R900 631 106 90 \\$2.25](#)
2. Dual Filament Front Turn Signal/Parking or Rear Brake Light/Parking Light ... [R900 631 128 90 \\$3.30](#)
3. Single Filament Rear Turn Signal or Reverse Light ... [R900 631 127 90 \\$2.31](#)
4. 1975-76 License Plate Light 12V 5W ... [G900 631 104 90 \\$2.20](#)
5. Front Sidemarkers/Rear Outboard Sidemarkers/1970-74 License Plate Light 12V 4W ... [R900 631 103 90 \\$2.20](#)
6. Large Instrument 12V 4W ... [R900 631 129 90 \\$2.20](#)
7. Small Instrument Light Bulb 12V 1.2W ... [R900 631 102 90 \\$1.44](#)



Black Silicone For Sealing Tail Light Bodies

We field more questions about how to seal the tail light bodies to the rear panel! Well now we are telling you! Versatile silicone sealant perfectly seals the bodies just like the factory did in all of the later cars.

Simply clean the body, run a bead around the original seal, plant against the panel, bolt in, and let dry. It's that easy, and yes, your trunk will be that dry!

Black Silicone ... [GAC08609 \\$18.50](#)

G = Genuine • R = Aftermarket / Replacement •
U = Used • B = Rebuilt or Reproduction

ELECTRICAL

REBUILT INSTRUMENTS

Rebuilt? No, you'll think they are new! The number one VDO authorized rebuilder in the country does these for us and they are beautiful! Sold on an exchange basis only. Core charge of \$150.00 per instrument applies.



1970-72 914 120MPH Speedometer
... [B914 641 504 20 \\$192.50](#)



1973-74 914 150MPH Speedometer
... [B914 641 505 20 \\$185.00](#)



1974.5-76 150MPH Speedometer
... [B914 641 504 30 \\$192.50](#)



1970-74 Fuel Gauge
... [B914 641 102 40 \\$265.00](#)



914-6 Fuel/Temp Gauge
... [B914 641 101 20 \\$275.00](#)



1970-74 Fuel/Temp Gauge
... [B914 641 102 40 \\$265.00](#)
1974.5-76 Fuel/Temp Gauge
... [B914 641 101 50 \\$265.00](#)



Tachometers

- 1970-73 914-4 Tachometer
... [B914 641 302 10 \\$253.14](#)
- 1970-72 914-6 Tachometer
... [B914 641 301 10 \\$253.14](#)
- 1974.5-76 914-4 Tachometer (Shown)
... [B914 641 302 12 \\$265.00](#)

Tech tip: if the odometer has stopped turning but the speedometer still works, the speedometer head needs rebuilding.



VDO Oil Temp Gauge ... RVDO310 106 D \$71.45



VDO Head Temperature Kit (gauge w/ sensor) ... RVDO 310 980 \$87.95



VDO Oil Pressure ... RVDO 350 040 \$71.45



VDO Analog Clock ... RVDO 370 021 \$105.00
Factory Rebuilt Clock (Pictured) ... B914 641 119 10 \$214.50 each (Core Charge \$100.00)



VDO Voltmeter ... RVDO 332 041 \$71.45



VDO Fuel Gauge ... RVDO 301 030 \$65.95



VDO Gauge Spacer Ring

This ring works perfectly to fit the smaller aftermarket VDO gauges into the larger factory center console hole.

Spacer Ring ... [RVDO 600 851 \\$11.00](#)

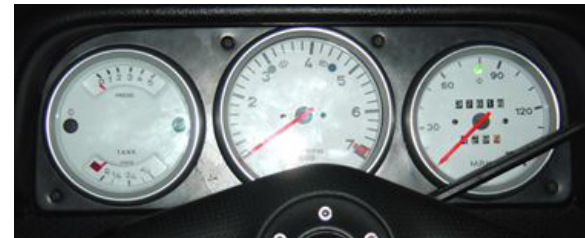

Aluminum Gauge Plate

This cluster is laser cut from a billet aluminum and has brushed aluminum (unpainted) finished. It will fit all modern size instruments and 1/2 inch wide holes for warning lights (see part number BMB 241 73). Warning light are located inside the original instruments. They are; Alternator, Brakes, Oil, Parking, High Beam, Turn. Other kinds of Autometer products can be fitted inside. Our site features an entire Autometer inventory for your needs. In addition, VDO and Autometer sell this inexpensive device to convert a mechanical speedometer cable to the electronic impulse signal. Old cluster has outdated size openings to have the ability to install modern-size instruments. We will ship this cluster with 1/8 thick cardboard template simulating this cluster, so you can practice and pre plan the installation before actual piece is installed.

Aluminum Gauge Plate ... [RMB24172 \\$95.00](#)



VDO Fuel, Oil Pressure And Oil Temperature Gauge Combined Instrument

This VDO triple cluster will fit in place of your combi instrument, works with original fuel sender, dual pressure sensor, temperature sender, and push-on connector included in kit, factory dash gasket, mounting brackets, nuts, bulbs, and sockets included, 6 or 12 Volt operation, any U.S. or metric face scales available. Please specify red or silver needles. No core charge on this item!

Combination Gauge ... [R914 641 101 303 \\$650.00](#)

Gauge Holder & Rings

If your 914 does not have the center console and you need adequate monitoring of your critical systems, you need a VDO gauge holder. Available in both steel and heavy rubber, order your particular application.

- Holder Single Steel ... [RVDO 240 027 \\$13.75](#)
- Holder Single Rubber... [RVDO 240 802 \\$27.44](#)
- Holder Double Steel ... [RVDO 240 028 \\$19.25](#)
- Holder Double Rubber ... [RVDO 240 803 \\$31.84](#)
- Holder Triple Steel ... [RVDO 240 029 \\$26.95](#)
- Holder Triple Rubber ... [RVDO 240 804 \\$32.94](#)

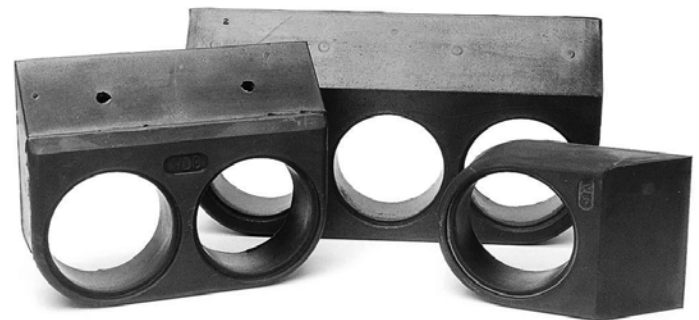

ELECTRICAL



WINDSHIELD BOLSTER GAUGE HOLDER

Bolster gauge plate for the real racer! Is your 914 so full of extra gauges that you have no more room for any more? Don't worry - two more can be easily mounted on this nifty bolster gauge holder! Easily replaces the left windshield bolster and provides direct line viewing of your 914's important or less important functions! Sturdy fiberglass construction. Gauges not included.

Windshield Bolster Gauge Holder ... [RVDO184 997 \\$38.50](#)

Instrument Bulbs

Large Instrument 12V 4W ... [R900 631 102](#)

Small Instrument Light Bulb 12V 1.2W ... [R900 631 132 90 \\$2.20](#)



Fresh Air Grille Seal

Repro for all 1974-76 models with black grille.

... [B914 571 129 10 \\$25.00](#)



Blower Box Hose and Seal

By now even the sheltered front blower box hose has deteriorated to the point of looking bad. Easily renewed, order the 2.25" size for the blower box connections and the 2.0" size for the side dash vents. One hose length will replace one side. The seal, often overlooked, seals the blower box to the cowl and prevents water from entering this critical area. Easily replaced with the blower box still in the car, this would also be a great time to clean the 1973-76 blower grille! One length does both sides.

2.0" Blower Box Hose for Dash Side Vents, 1972-76

... [R028 129 087 \\$30.03](#)

2.25" Blower Box Hose for Main Vents and Behind Speaker Grilles

... [R911 211 522 00 \\$29.64](#)

Blower Box Seal 1970-72

... [G571 904 107 \\$19.50](#)



Reproduction 5-Speed Shift Knob

Great reproduction of the factory original. In keeping with the factory tradition we are proud to offer this beautiful factory-look shift knob, which duplicates the original long discontinued Porsche original but with a billet aluminum shift pattern insert! Manufactured from high strength delrin plastic the knob fits all 911 1965-71, 912 1965-76 and 914 1970-76. This knob is so good that it will pass for concours application as the judges will appreciate your effort at factory tradition!

Reproduction 5 speed knob

... [B901 424 014 00 \\$74.50](#)

Shift Knob Crush Sleeve (to install knob)

... [B999 532 001 00 \\$4.50](#)



Control Switch Slider

For ventilation system. With bezel, USA. Complete with cables.

Control Switch Slider ... [G914 613 134 13 \\$341.13](#)

Single or Dual Condenser Air Conditioning Kit

From the genius who designed the original DPD and VPC factory air condition systems for Porsche comes the brand new 2010 ice cold 914 custom fit air conditioning system. Using the latest R134 technology, the kits are super efficient robbing the engine virtually of no power while providing super efficient cooling. Both kits easily mount a condenser in the front under the spare tire. The system is 16,000 BTU and puts out 320 CFM of air. (the factory was 8,000 btu & 220 cfm). The mount/drive kit to use a multi-poly belt drive belt (same as the new car use today) and we now use a Sanden 8 cubic inch rotor compressor that only pulls 1.5 horsepower of off the motor, instead of 14 like factory did. Comes complete with instructions.

Single Condenser Air Conditioning Kit

... [RAA 030S \\$2,475.00](#)

Dual Condenser Air Conditioning Kit

... [RAA 030D \\$2,695.00](#)

Air Conditioning Manual

... [BTC 1001 \\$16.50](#)

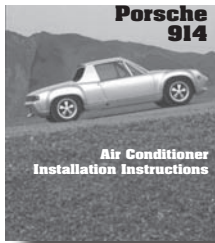

Fresh Air Blower Motor

For all 914's! Now, a cheap fix for the often bad fresh air blower motor. Brand new from our friends at Bosch.

... [G461 261 193 \\$121.43](#)

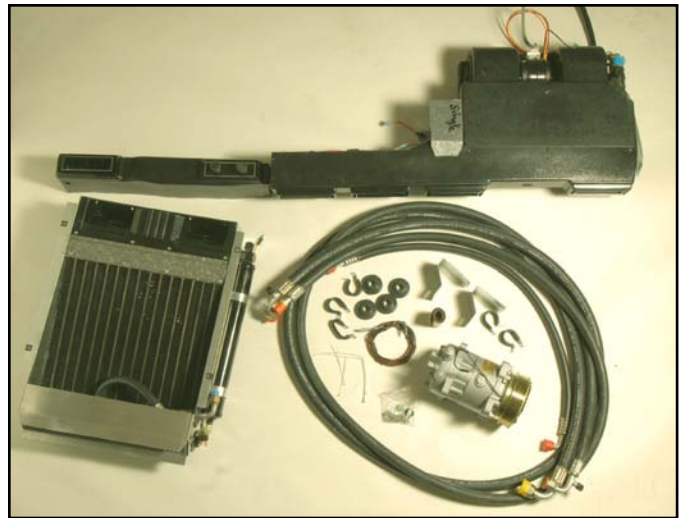
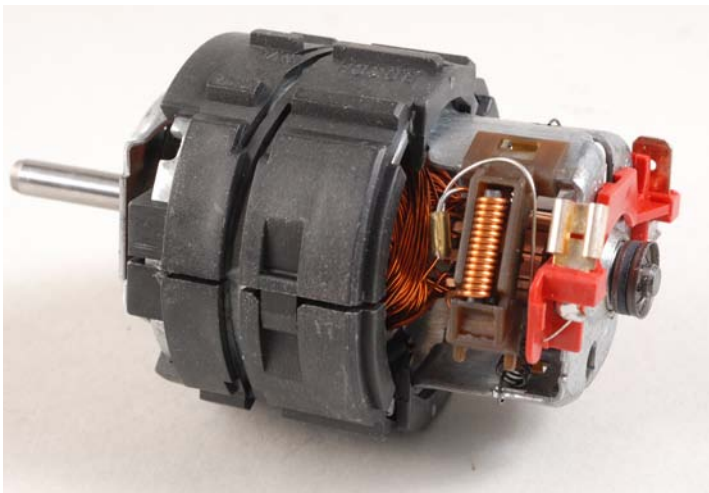

Get on our specials list! Just send an email to info@autoatlanta.com.

ACCESSORIES

BLAUPUNKT AM/FM CD & CASSETTE RECEIVERS

Blaupunkt radios were original equipment in 914s, and these latest units update your 914 to the fabulous sound of a modern system while still fitting perfectly into the dash.

High Power - Great Features - Perfect Fit - Low Cost!



Venice Beach CD34

A 180W high-power AM/FM/CD receiver with a flip down detachable faceplate and included RC12 remote control; XBass; 45 watts x 4 channel peak power with 4-8 Ohms speaker impedance; 2V auxiliary input; 2 preamp outputs at 1.0V; 8x oversampling rate to prevent skips; CD-R and CD-RW compatible; 3-band preset equalizer with bass and treble controls.

Venice Beach CD34 ... [RBL34243 \\$186.95](#)

Hollywood C30 Cassette Receiver Radio

160W Hi-Power Cassette Receiver with CD Changer Control; 40 Watts (Max.) x 4-Ch; 4-Ch Low Impedance Pre-Out @ 4V; 15FM / 10AM Preset Stations Including Travelstore Presets; Electronic Detachable Faceplate; Blaupunkt's Exclusive Autoreverse Cassette Deck With Radio Monitor; Digital Clock & Blue Illumination; DMS CD Changer Controller Provides Mix 1 & 2, Repeat, & Scan; Menu Features Include: Telephone Mute, 6-loudness Levels, Radio Monitor On/Off, Mute, Adj. Scan Time, Source Tone Memory, Clock, & Aux-In; Optional IR Thummer Steering Wheel Remote; DIN/ISO Mounting.

Hollywood C30 Cassette Receiver Radio

... [R7640135510 \\$197.95](#)



Stealth Subwoofer Kit

For years we 914 owners suffered tinny stereo sound, as the air tubes behind the factory speaker grilles absorbed any bass the speakers could produce. Door speakers solved this problem — but who wanted to cut holes in pristine factory door panels? Finally a solution! Using the original foam block behind the passenger bulkhead carpet, we have engineered a setup that provides great bass, while retaining a clean concours look! Kit includes a custom matched set of 8 inch Audiobahn 500 watt speakers mounted on a custom made plate, Audiobahn 800 watt amplifier and a plug-in cable kit.

Stealth Subwoofer Kit BAA 319 34 \$544.50



Blaupunkt Speaker Kit

Only the best for your 914. Fabulous high powered modern speaker kits replace the old dilapidated low power originals & fit the speaker grilles, or use the grills for an updated look. These fabulous two-way speakers handle 105W per channel & provide fantastic response. Speaker measures 4"X6".

Blaupunkt Two-Way Speaker Kit (set) ... [RPCXG462 \\$89.95](#)

Screws & Washer Kit To Mount Speakers Into 914 Enclosure ... [REL 1101 \\$7.65](#)





BLAUPUNKT

Speaker Kit

Two powerful 180w 5.25" Blaupunkt speakers with our custom, perfect-fit speaker housings create modern audio performance for your 914.

Speaker Kit ... [R914 525 180 SS \\$250.00](#)



Electric Antenna & Manual Mast

Is your antenna rusty? Try one of our new German Hirschmans! They custom fit your 914 and are available in manual or electric. Both tuck away to avoid breakage, and our electric antenna works automatically when you operate your radio.

Manual Chrome Antenna ... [REL 4503](#)

1975-76



1970-74



DIN Radio Face Plate

Has your radio face plate been ruined from previous installation? Try one of our brand new ones! Available in regular or DIN cuts. It highlights any stereo installation!

DIN Radio Face Plate, 1970-1974

... [B914 552 040 11](#)

\$27.50

DIN Radio Face Plate, 1970-1974, For Newer Radios

... [B914 552 040 A2](#)

\$24.20

914

should this car be saved?

Yes! As we write, the car is on our framrack being straightened and brought to factory dimensions. From parts on hand (the world's largest inventory), we can make the 914 as good as new: a modern, fuel-efficient convertible sports car that can be driven for miles of pleasure.

Owning a 914 is owning a piece of Porsche history never to be repeated. With values rapidly escalating and parts available, all 914's are worth saving. At Automobile Atlanta we are dedicated to 914 preservation and restoration.

Automobile Atlanta offers the definitive 914 catalog/technical manual. Over 75 pages of parts and advice for \$4.00. Order yours today and stay tuned for more 914 news.

George Hussey, president of Automobile Atlanta is technical chairman of the 914 Owners Association and advisor for "914 Restorer's Guide to Authenticity". He is always available for how-to advice.

Call 404-427-2844

505 S. MARIETTA PKWY, DEPT. VWP, MARIETTA, GA 30060

Vintage Ad

ACCESSORIES



License Plate Brackets

Critical equipment for state governments! Don't be caught without one! Brackets include all necessary mounting hardware.

Front Bracket (Shown) ... [G911 701 053 00 \\$49.95](#)

Rear Bracket ... [G914 701 056 10 \\$49.55](#)

European License Plate

20.5X4.5 inches. This plate is the same size as Euro plates. Made of high quality metal and professionally stamped. Combine this plate with our Euro bracket for a fantastic look on your Porsche. (Order any printing you like!)

European Plate ... [REU 33536 \\$71.50](#)



European License Plate Bracket

For license plates measuring 20.5X4.5 inches, which is the European standard.

This bracket is easy to install and also easy to use with your plates. Made of high quality molded plastic and is very durable. Combine this bracket with our Euro plates for a fantastic look on your Porsche.

European Bracket ... [RG8 31927 \\$18.69](#)

License Plate Frames

Finally, all stainless steel license plate frames...No more rust stains. From Porsche, of course. Appropriately finished & packaged with matching colored caps for your screw heads (4). Priced per each.

Titanium Gold/Brass

... [GPNA70200200 \\$66.46](#)

Black Stainless

... [GPNA70200500 \\$46.70](#)

Black Carbon Fiber

... [GPNA70201700 \\$78.00](#)

Matte Silver

... [GPNA70201400 \\$46.70](#)



Porsche® License Plate

For those of you who can wear a front license plate on your 914, or just to hang in your hobby garage. This brightly crested, factory authorized, plate is required equipment for the Porsche enthusiast.

Porsche® License Plate ... [GPNA 701 001 \\$16.79](#)



European Style Crest Plate

These plates are European sized (approx. half the height of U.S. plates) but fit the normal license mounting holes. Authentic Porsche Crest. Creates a far sleeker appearance while making a more powerful & dramatic statement. Match with the Crest wheel center caps for ultimate visual impact. Check with local and state tag laws.

Black Powder Coated ... [GPNA 703 001 00 \\$95.03](#)

Brushed Satin Stainless ... [GPNA 703 002 00 \\$95.03](#)

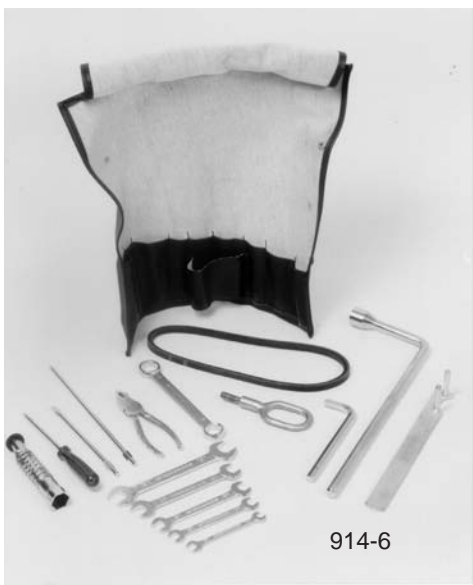

914-6



1970-72 914-4



1973-76 914-4

Factory-Look Tool Kit For 914-6 & 914-4

Once again, you can have a factory original tool kit for your 914. Available in three styles. Admittedly you don't get many tools for the money, but what a great Concours display item!

1970-72 914-4 Tool Kit ... [B411 012 021 \\$91.50](#)

1973-76 914-4 Tool Kit ... [B411 012 021B \\$65.00](#)

1970-72 914-6 Tool Kit ... [G914 721 001 10 \\$673.07](#)

Jack Straps

These factory original replacements require your metal ends to work, (why did the factory do this?) but the rubber is the exact stuff. For all 1972.5-76 (two required)

Jack Straps ... [G914 722 021 10 \\$36.41/each](#)

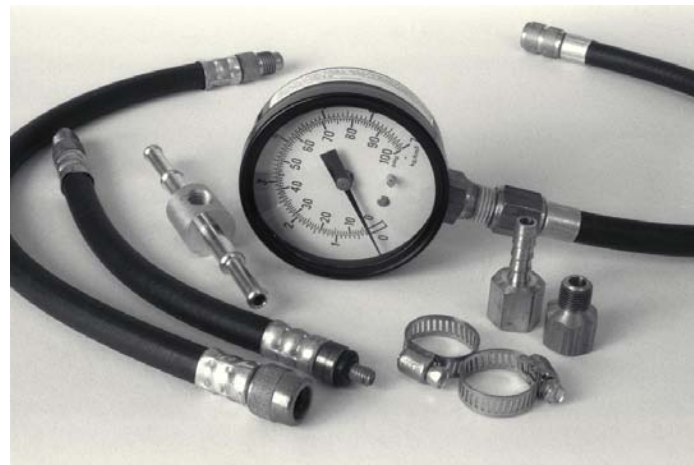

Fuel Injection Pressure Tester

We receive calls daily for a high pressure fuel gauge and we are surprised one cannot be found at a local parts store. But, alas, it seems not available and it is a must when troubleshooting fuel injection problems. Besides giving extremely accurate readings of your 914's fuel pressure, this high quality tester will also work on other Porsche® injection systems. Make sure you have this device handy before you call Dr. 914 for fuel injection advice!

Fuel Injection Tester ... [RTL 1031 \\$114.34](#)

914 Fuel Injection Operation

Daily we receive calls for a high pressure fuel gauge and we are surprised one cannot be found at a local parts store. But, alas, it seems not available and it is a must when troubleshooting fuel injection problems. Besides giving extremely accurate readings of your 914's fuel pressure, this high quality tester will also work on other Porsche injection systems. Make sure you have this device handy before you call Dr. 914 for fuel injection advice!

Fuel Injection Operation

... [BTC1016 \\$11.00](#)

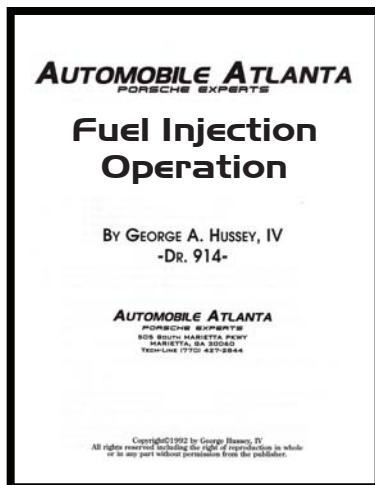

AUTOMOBILE ATLANTA
PORSCHE EXPERTS

Fuel Injection Operation

BY GEORGE A. HUSSEY, IV
-DR. 914-

AUTOMOBILE ATLANTA
PORSCHE EXPERTS
808 SOUTH HARRIS BLVD
HARRIS, GA 30228
TELEPHONE (770) 487-2844

Copyright©1992 by George Hussey, IV
All rights reserved including the right of reproduction in whole
or in any part without permission from the publisher.

Synchrometer

The ultimate carb tool to perfectly adjust air flow and balance linkage. No more "by ear" adjustments. With the synchrometer, you can quickly and easily adjust your carbs to a perfect tune.

Synchrometer ... [RTL 1009 \\$39.50](#)



ACCESSORIES



914 Hardware Kit - A Dr. 914 Original! GIVES YOU TWO SCOOPS OF RARE NUTS, BOLTS, SCREWS AND WASHERS

Our hardware kit is the most important tool you can purchase to repair your 914. We give you two scoops of rare 914 nuts and bolts accumulated from hundreds of disassembled 914's. Have you ever been stalled for the lack of a specific 914 bolt? No longer!

Hardware Kit ... [UN0 100 000 \\$12.00](#)



Piston Ring Compressor

Tried getting a standard piston ring compressor around head studs? Then you know how wonderful this correct ring compressor could be!

Piston Ring Compressor 87-94mm ... [RTL 1011 \\$23.04](#)

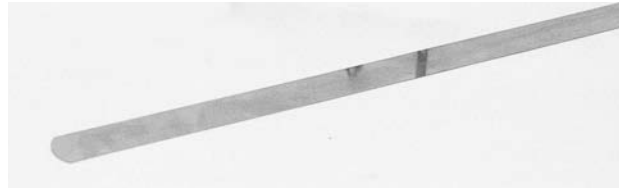

Valve Adjustment Tool

The valve adjustment gauges come in .006mm for 1.7, 1.8 and 2.0 models, and .008mm for 2.0 exhaust valves. Both are designed for easy access to the hidden 914 rocker arms!

.006 Feeler Gauge ... [RTL 1407 \\$14.15](#)

.008 Feeler Gauge ... [RAA 061 \\$5.50](#)

914-6 Valve Adjust Tool

Original factory tool will assure the correct setting every time. Easy to use for the adjustment of your 914-6 valves.

914-6 Valve Adjust Tool

... [RTL 1022 \\$7.50](#)

Extra Blades

... [RTL 1040 \\$7.50](#)

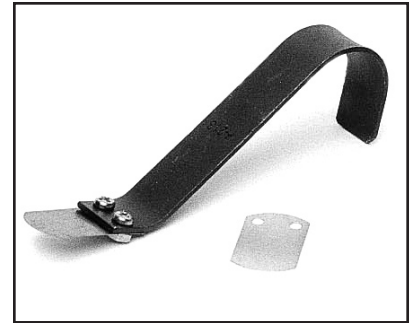

Flywheel Lock

The handiest when doing engine work. Securely locks the flywheel to the engine case with no effort and allows precise torquing of all essential bolts.

Flywheel Lock

... [RTL 1021 \\$23.98](#)



Oil Filter Removal Tool

Tucked away as not to be hit by road debris, the 914 oil filter is easily removed with the proper tool and we have it! Now you can use a ratchet wrench to remove your filter cleanly and easily.

Filter Tool 914/911 ... [RTL 1035 \\$11.55](#)



Clutch Alignment Tool

The clutch alignment tool is a must for proper 914 clutch installation and alignment.

Clutch Alignment Tool ... [RTL 1406 \\$6.93](#)

Weber Carburetor Float Level

If your 914-6 loses power at high speeds or low speed rich running and you haven't checked the float level, you've missed an important diagnosis. Float level is critical for proper carb tuning. This custom designed tool easily accesses the float bowl and is calibrated for precise measure.



Carb Float Level Gauge ... [GP226A \\$73.20](#)

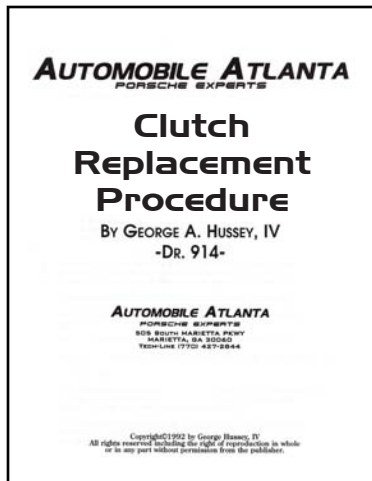

Clutch Replacement Procedure

Refundable with clutch purchase!

... [BTC1007 \\$11.00](#)



End Play Tool

Imperative when installing a new flywheel, to recheck and set the rear end play!

End Play Tool
... [RACC C10 7095 \\$19.50](#)

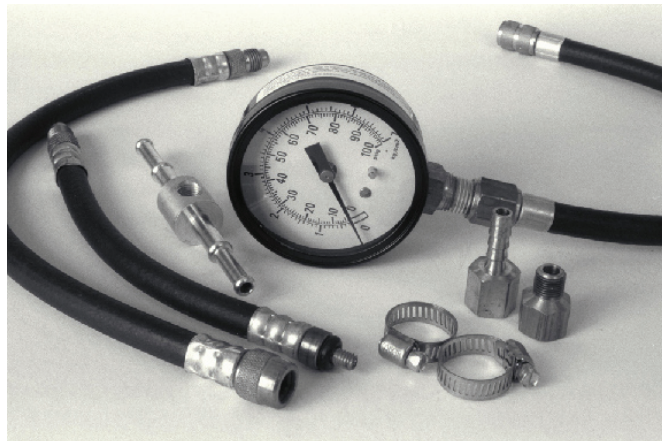

Fuel Injection Pressure Tester

We receive calls daily for a high pressure fuel gauge and we are surprised one cannot be found at a local parts store. But, alas, it seems not available and it is a must when troubleshooting fuel injection problems. Besides giving extremely accurate readings of your 914's fuel pressure, this high quality tester will also work on other Porsche® injection systems. Make sure you have this device handy before you call Dr. 914 for fuel injection advice!

Fuel Injection Tester ... [RTL1031 \\$114.34](#)



Transmission Filler Tool

The transmission filler tool is a 17mm allen, and you cannot change the fluid without it. Works on all Porsches, 1950 to 1994.

Transmission Filler Tool, 17mm ... [RTL1033 \\$7.51](#)

CV Joint Tool; All Models

The CV joint tool is essential. Periodic checking of the tightness prevents you from being stranded in the middle of nowhere when a loose one lets go! Handy 3/8 socket tool to hold it.

CV Joint Tool ... [RTL066 \\$7.70](#)

3/8-Socket Holder Tool ... [RTL1034-6 \\$13.15](#)

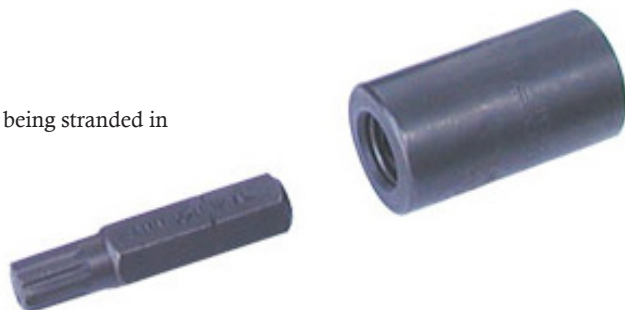

ACCESSORIES



Brake Bleeder/Vacuum Tester

Does your 914 high-low idle (hunt)? Is your 914 running too rich or too lean? Do you not have an assistant to help you bleed your brakes? Does Dr. 914 ask you to measure engine vacuum or evacuate your pressure sensor when you call him for technical assistance? What you need is this handheld brake bleeder/engine vacuum tester!

Good for thousands of applications, the heavy duty steel version will last the life of your tool collection. Don't be without one, and save yourself lots of time and frustration!

Metal Vacuum Tester/Brake Bleeder ... [RTL 2002 \\$76.95](#)

Plastic Vacuum Tester/Bleeder ... [RTL 1012 \\$43.45](#)

Power Bleeder

With a POWER BLEEDER, one person can easily, safely, and effectively bleed the hydraulic system like a professional, only cheaper! Bleeding has never been easier. There's no need for a helper to constantly pump the pedal while you open and close the bleed valves. And the 2 liter tank prevents the need for constant refilling of the fluid reservoir, thereby avoiding corrosive spills. Our precision pressure gauge prevents over pressurization and our custom machined adapter securely attaches to the fluid reservoir for the safest and most effective operation; The hand-operated pump is built in - no other pressure source (air compressor, spare tire) is needed.

Fast, easy and reliable one-person operation. Works on hydraulic clutch systems, too.

Motive Power Brake Bleeder ... [RMP0104 \\$54.94](#)

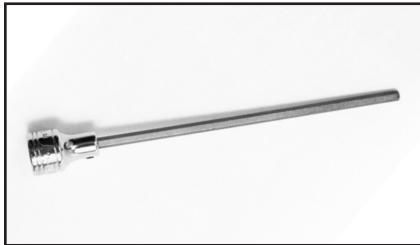

4mm Allen For Set Screws and Side Pockets

This handy allen is essential for your 914 tool box in that it is the proper size and length to access the inaccessible! Fits easily into your 3/8" drive ratchet.

4mm Allen ... [RTL 1407 \\$14.15](#)

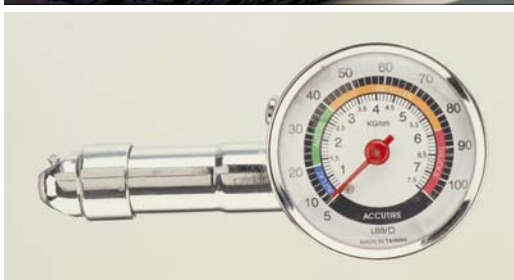

Tire Gauges

Get an accurate reading in any temperature, altitude, or climate. Digital tire gauges are the most accurate and easy to use. Chrome dial style looks good in your factory tool kit at the Concours outings. Add life to your tires! 5-99 PSI. 1 lb resolution.

1. Digital Deluxe Tire Gauge with Case ... [RMS4000 \\$41.79](#)
2. Grip Style Tire Gauge ... [RTL 1004 \\$24.15](#)
3. Chrome Tire Gauge ... [RMS5008 \\$14.96](#)

Digital Camber Gauge

Have you ever been at the track and thought your Porsche™ might be a little better with another 1/2 degree negative camber, but did not want to shell out another \$250.00 for an alignment? Well, now you can make camber adjustments yourself with this lightweight digital camber gauge. Accurate to a tenth of a degree. No track-side tool box is complete without one!

Digital Camber Gauge ... [RTL2500 \\$299.14](#)



Soft Socket

For 914-6 alloy nuts. Your choice: the soft nylon inserted, steel socket, or the all alloy socket. Both are gentle on your aluminum lug nuts.

Soft Socket w/Nylon Insert ... [RTL 1007 \\$32.95](#)
Forged Soft Socket ... [RTL 1008 \\$32.95](#)



Jacking Plate

Save that sheet metal! Keep rocker panels and floorboards dent free with our handy jack plates. Floor jack plates fit factory jack locations perfectly, and the wide base fits into the floor jack, so that slippage is not a worry. Save your fragile factory jack for roadside emergencies and order a jack plate for your service needs.

914 Jacking Plate ... [RTL 1037 \\$21.94](#)

Compressor Tire Inflator

We chose this high inflation (300 PSI) mini-compressor because of its compact size and powerful inflation! This little device will inflate a life raft, along with your spare tire, basketball, or bicycle tire. Plugs directly into the lighter socket and with its eleven foot cord will reach around your Porsche! Has a built in gauge along with all of the attachments.

Compressor Tire Inflator ... [BPNA113104 \\$78.14](#)



Automobile Atlanta car display, featuring the Limited Edition 914



ACCESSORIES



914 Hardware Kit - Dr. 914 Recommended! GIVES YOU TWO SCOOPS OF RARE NUTS, BOLTS, SCREWS AND WASHERS

Our hardware kit is the most important tool you can purchase to repair your 914. We give you two scoops of rare 914 nuts and bolts accumulated from hundreds of disassembled 914s. Have you ever been stalled for the lack of a specific 914 bolt? No longer!

Hardware Kit ... [UNO 100 000 \\$12.00](#)

Volt Tach Dwell Meter

Every time we give tech advice, it seems that no one has one of these. Since most cars these days have electronic ignition, it was almost impossible to find a combination tool with a dwell reading, but we did, and offer this high quality instrument to you.

Volt Tach Dwell Meter
... [RTL2501A305 \\$86.63](#)



12-Volt Test Light

The 12 V test light is in all of our tool boxes and is a must for any electrical testing. Do not attempt electrical diagnosis unless you own one of these!

12V Test Light ... [RTL 1029 \\$13.86](#)



Alternator Belt Removal Tool For 914-C

... [RTL1025 \\$35.23](#)

Halon Fire Extinguisher

Fire Extinguishers should be installed in each of your vehicles. Halon Fire Extinguishers are the only fire extinguishers that won't choke you, won't damage your vehicle's electrical system or harm your expensive paint job. Halon is colorless, odorless, non staining (leaves no residue), non corrosive, non conductive and it will not impairment of operator's vision. These Halon Fire Extinguishers are Compact, lightweight and easy to operate.

Halon Fire Extinguisher ... [RSEEXT1C SC250130 \\$185.90](#)



4mm Allen For Set Screws and Side Pockets

This handy allen is essential for your 914 tool box in that it is the proper size and length to access the inaccessible! Fits easily into your 3/8" drive ratchet.

4mm Allen Socket
... [RTL 1407 \\$14.15](#)

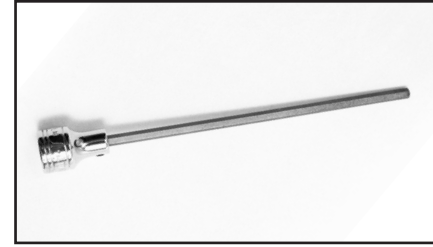

Magnetic Spark Plug Socket

How many of us have lost a spark plug in the 914 engine sheet metal? None of us who use this magnetic spark plug socket! Remember the 914 spark plugs don't use the screw cap that most spark plug sockets grab to remove. That's why you need the magnet!

Magnetic Socket ... [RTL 1027 \\$68.75](#)

Porsche Focus!

Maintenance, Tuning, Restoration & Gift Shop

Auto Atlanta: Porsche enthusiasts serving Porsche enthusiasts. For 30 years, we have serviced nothing but Porsche automobiles. We take extra care, whether it's installing a cold-air intake system on your Boxster to a full-blown restoration of your 356, perfectly repairing that torn seat on your 914 or installing brake pads on your Cayman.

Our prepared Porsches have won national awards for perfection. You will see us at all Porsche Club events.

AUTOATLANTA

The best in Porsche service since 1978
770-427-2844 www.AutoAtlanta.com



ACCESSORIES



Digital Pyrometer

This will fast become one of the most used tools in your box! Perfect to measure tire temperature at the track, adjusting carbs, diagnosing engine mis-fire, AC testing, even take your own temperature when your best buddy passes you or when your girlfriend gets into your car!

Digital Pyrometer ... [RTL 1042 \\$292.50](#)

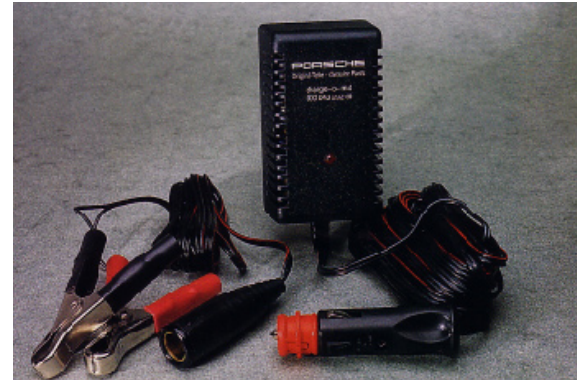

Battery Charger & Maintainer

Do you own an "occasional use" Porsche or other classic car? Our factory charger/maintainer will keep your car or boat ready to with a full battery charge. its deep cycle slow charge will not overcharge and boil your battery. It's safe and dependable and will pay for itself with the 1st battery it saves.

Battery Charger & Maintainer ... [G000 043 202 56 \\$88.00](#)



Jump Start Pro

Never again be stuck with a dead battery! The Jumpstart Pro is completely portable, safe, and convenient! The unit may be charged from household or auto current with the included power cords. An easy to read power indicator alerts you to the power status at all times. Reverse polarity warning, keyless on/off switch, 110 volt AC power outlet, 200 watts, also includes a built in work light. The Jump Start Pro may be stored in in any position without risk of leakage. Maintenance free, heavy duty battery is also sealed for extra protection. The uses are limitless. (Appearance may be different than shown.)

Jump Start Pro ... [RVEC021AC \\$153.94](#)

Bulb Kit



Great item! At least ten bulbs and one of every bulb in the exterior of your car and some for the instruments. A great value.

Bulb Kit ... [BAA200 \\$11.00](#)

Fuse Assortment Kit

For all 914 models

... [BAA067 \\$3.50](#)



914-6 TIMING DECALS



1 Finally available! For the true enthusiast or just to know how to adjust your 914! These stickers give your car that finishing Concours touch!

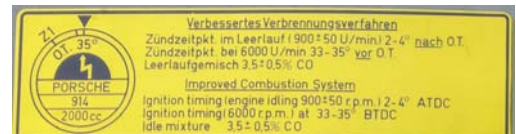

1. Euro 914-6 Timing Decal ... [G901 106 509 00 \\$21.67](#)
2. '70 US 914-6 Timing Decal ... [G901 006 509 02 \\$21.67](#)
3. '71 US 914-6 Timing Decal ... [G901 006 509 03 \\$21.67](#)
4. '72 US 914-6 Timing Decal ... [G901 006 509 09 \\$21.67](#)

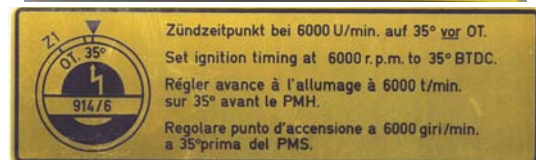

Engine and VIN Stickers

- 1. 914-4 155 Tire Pressure
... [G914 006 501 10 \\$12.95](#)
- 2. 914-4 165 Tire Pressure
... [G914 006 505 10 \\$12.95](#)
- 3. 1970-71 Door Jamb Sticker
... [BAAA 006 701 700 \\$11.00](#)
- 4. 1972 Door Jamb Sticker
... [BAAA 006 7200 \\$11.00](#)
- 5. 1973-76 Door Jamb Sticker
... [BAAA 006 7300 \\$11.00](#)
- 6. 914-6 Tire Pressure Decal
... [B914 006 501 00 \\$11.00](#)
- 7. 914-6 Valve Adjust
... [B901 006 503 00 \\$11.00](#)
- 8. 914-6 Firing Order
... [B901 006 502 00 \\$11.00](#)
- 9. 914-6 Alternator
... [B901 006 508 00 \\$11.00](#)
- 10. 914-6 Oil Level
... [B901 006 504 01 \\$11.00](#)
- 11. 2.0 Valve Adjust Sticker
... [B039 100 175 \\$11.00](#)

- 12. 1.7, 1.8 Valve Adjust Sticker
... [B022 100 175 \\$11.00](#)
- 13. 1975-76 Tire Pressure Decal
... [G914 006 505 11 \\$15.73](#)
- 14. 1973 1.7 Engine Compartment Decal
... [B021 133 033 BJ \\$15.73](#)
- 15. 1974 1.8 Engine Compartment Decal
... [B022 133 033 BG \\$11.00](#)
- 16. 1974 2.0 Engine Compartment Decal
... [B039 133 033 BJ \\$11.00](#)
- 17. 1975 1.8 Engine Compartment Decal
... [B022 133 033 BH \\$11.00](#)
- 18. 1976 2.0 Engine Compartment Decal
... [B022 133 033 BJ \\$11.00](#)

1

VW Porsche 47
 Veh. cab. w. lbs 705
 Tire Standard 155 SR15
 Cold infl. press. 23/26 psi
 all front rear
 Seat positions 2

2

VW Porsche 47
 Veh. cap. w. lbs 550
 Tire Standard 165 SR15
 Cold infl. press. 26/29 psi
 all front rear
 Seat positions 2

3

MANUFACTURED BY Dr. Ing. h. c. F. PORSCHE KG
 THIS VEHICLE CONFORMS TO ALL APPLICABLE FEDERAL MOTOR VEHICLE SAFETY STANDARDS IN EFFECT ON THE DATE OF MANUFACTURE SHOWN ABOVE.

4

MANUFACTURED BY VOLKSWAGENWERK AG
 THIS VEHICLE CONFORMS TO ALL APPLICABLE FEDERAL MOTOR VEHICLE SAFETY STANDARDS IN EFFECT ON THE DATE OF MANUFACTURE SHOWN ABOVE.

5

MANUFACTURED BY VOLKSWAGENWERK AG
 THIS VEHICLE CONFORMS TO ALL APPLICABLE FEDERAL MOTOR VEHICLE SAFETY STANDARDS IN EFFECT ON THE DATE OF MANUFACTURE SHOWN ABOVE.
 GVWR LB. 2690
 GAWR LB. FRONT 1433/REAR 1433

6

VW Porsche	914 / 6
Veh. cab. w. lbs	705
Tire Standard	165 HR 15
optional	185 / 70 VR 15
"	185 HR 14
Cold infl. press.	26 / 29 psi
all front rear	
Seat positions	2

7

0.1mm (0.004")
 Ventilspiel kalt
 valve clearance cold
 jeu des soupapes à froid
 0.1mm (0.004")

8

Zundfolge
 firing order
 ordre d'allumage
 1 - 6 - 2 - 4 - 3 - 5

9

Generator und Regler Müssen vom gleichen Hersteller sein!
 Alternator and regulator must be from the same manufacturer!
 Alternateur et régulateur doivent être de la même marque!

10

Motorölstand bei warmen Motor im Leerlauf.
 Warm engine oil level at idling speed.
 Niveau d'huile du moteur chaud en marche à vide.

Anzeegerät Oil level gauge Appareil indicateur	Ölmeßstab Oil dipstick Jauge d'huile
min. 5 Liter quarts litres	untere Kerbe lower mark cran inférieure
max. 7 Liter quarts litres	obere Kerbe upper mark cran supérieure

Einlaß 0,15 mm
Intake •006"
 Auslaß 0,2 mm
Exhaust •008"

11

0.15mm
•006

Max. Load (vehicle capacity weight): 485 lbs
 Designated Seating Capacity: 2

Tire Size: 165 SR 15 **13**

Cold Tire Inflation Pressure

Winter tires - add 3 psi		half load	max. load
Radial Ply Tires	front	26	26
914 006 505 11	rear	29	29

VEHICLE EMISSION CONTROL INFORMATION
 VOLKSWAGENWERK AG
 ENGINE CODE: EA ENGINE SIZE: 102.5 C.I.D.
 FUEL INJECTION
 IDLE RPM: 800 ± 50 IDLE CO SETTING: 1-3 VOL%
 ENGINE OIL TEMPERATURE: 122 - 158° F
 IGNITION TIMING: 27 B.T.D.C. AT 3500 R.P.M. VAC HOSES REMOVED
 ALL ENGINE TUNE-UP DATA ARE SET WITH TRANSM IN NEUTRAL
 THIS VEHICLE CONFORMS TO E.P.A. AND CALIFORNIA REGULATIONS APPLICABLE TO 1973 MODEL YEAR NEW MOTOR VEHICLES
 CRANKCASE EMISSION CONTROL: PCV-SYSTEM **14**

VEHICLE EMISSION CONTROL INFORMATION
 VOLKSWAGENWERK AG
 ENGINE CODE: EC - B ENGINE SIZE: 109 CID
 FUEL INJECTION
 IDLE RPM: 850 ± 50 IDLE CO ≤ 4.5 VOL%
 ENGINE OIL TEMPERATURE: 122 - 158° F
 IGNITION TIMING: 7.5 BTDC VAC HOSES REMOVED
 ALL ENGINE TUNE-UP DATA ARE SET WITH TRANSM IN NEUTRAL
 THIS VEHICLE CONFORMS TO U.S.E.P.A. AND CALIFORNIA REGULATIONS APPLICABLE TO 1974 MODEL YEAR NEW MOTOR VEHICLES
 CRANKCASE EMISSION CONTROL: CLOSED-SYSTEM **15**

VEHICLE EMISSION CONTROL INFORMATION
 VOLKSWAGENWERK AG
 ENGINE CODE: GA ENGINE SIZE: 120 CID
 FUEL INJECTION
 IDLE RPM: 900 ± 50 IDLE CO SETTING: 2 ± 1 VOL%
 ENGINE OIL TEMPERATURE: 122 - 158° F
 IGNITION TIMING: 27 BTDC AT 3500 RPM VAC HOSES REMOVED
 ALL ENGINE TUNE-UP DATA ARE SET WITH TRANSM IN NEUTRAL
 THIS VEHICLE CONFORMS TO EPA AND CALIFORNIA REGULATIONS APPLICABLE TO 1974 MODEL YEAR NEW MOTOR VEHICLES
 CRANKCASE EMISSION CONTROL: PCV-SYSTEM **16**

VEHICLE CONTROL INFORMATION VOLKSWAGENWERK AG
 ENGINE FAMILY IDENTIFICATION: 15 DISPL: 109 CID
 IGNITION TIMING: 7.5 BTDC AT IDLE VAC HOSES REMOVED
 IDLE RPM 850 ± 50 IDLE MIXTURE CO VOL% 0.7 ± 0.5
 CARBON CANISTER HOSE AT AIR CLEANER DISCONNECTED
 VALVE LASH INTAKE •006 IN EXHAUST •006 IN
 ENGINE OIL TEMPERATURE: 122 - 158° F
 ALL ENGINE TUNE-UP DATA ARE SET WITH TRANSM IN NEUTRAL
 THIS VEHICLE CONFORMS TO USEPA REGULATIONS APPLICABLE TO 1975 MODEL YEAR NEW MOTOR VEHICLES **17**

VEHICLE EMISSION CONTROL INFORMATION VOLKSWAGENWERK AG
 ENGINE FAMILY 17 DISPLACEMENT 120 CID
 EXHAUST CONTROL SYSTEM EMERFI/AIR
 VALVE LASH INTAKE •006 IN EXHAUST •006 IN ENGINE COLD
 ENGINE OIL TEMPERATURE 122 - 158° F 150 - 170° F
 TRANSMISSION MANUAL AUTOMATIC IN NEUTRAL
 IGNITION TIMING 27 BTDC VACUUM HOSES DISCONNECTED
 TIMING AT RPM 3500
 IDLE CO VOL. % 2.8 ± 1.0
 IDLE SPEED RPM 900 ± 50
 CARBON CANISTER HOSE DISCONNECTED AT AIR CLEANER HOSE PLUGGED
 CRANKCASE EMISSION CONTROL SYSTEM DISCONNECTED
 AIR PUMP HOSE DISCON. DOWNSTREAM AIR PUMP TUBE PLUGGED
 THIS VEHICLE CONFORMS TO USEPA REGULATIONS APPLICABLE TO 1976 MODEL YEAR NEW MOTOR VEHICLES WITH THE EXCEPTION OF THE CARBON MONOXIDE STANDARD FOR CALIFORNIA **18**

ACCESSORIES

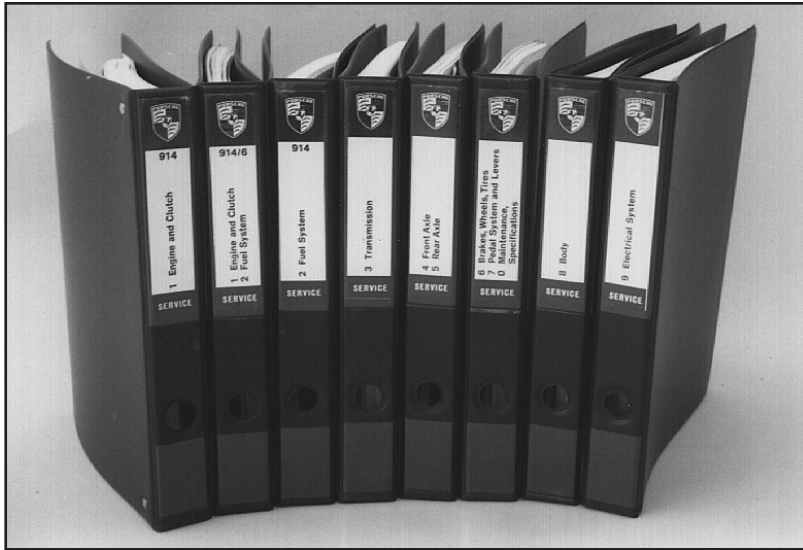

FACTORY REPAIR MANUAL

1970-76 914, 8 VOLUMES. The best manuals you can purchase for your Porsche, these concise books show everything to make repairs simple and accurate with easy to follow German logic! They may seem expensive, but if it saves you one repair trip to the Porsche dealer, they have paid for themselves!

Factory Repair Manual ... [GWKD480921 \\$1,005.95](#)
CD Factory Repair Manual ... [BKD343 \\$49.50](#)

914/4, 914/6 Repair Handbook

One of the few thorough and complete manuals to repair and rebuild the highly collectable 914. Our shop favorite! Contains information about the electrical, mechanical, and fuel systems. Fully illustrated. Also has a great section on the six cylinder 914. This is the old original Clymer manual that has been wildly popular for years.

Porsche 914 & 914-6 Handbook by Lash International ... [RBK7071 \\$24.50](#)

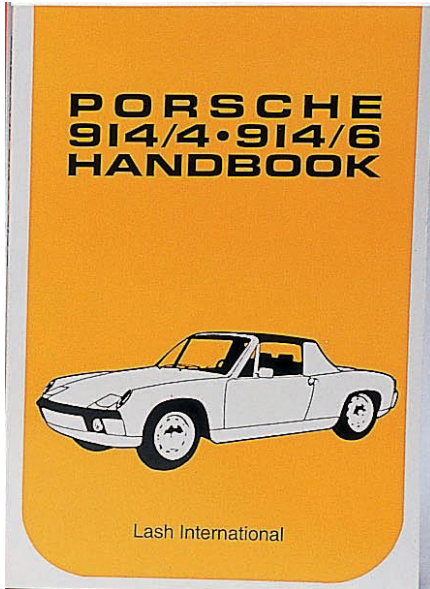

Haynes Repair Manual

The Haynes Manual is the world's best selling vehicle repair manual. Hundreds of pictures with easy to follow step-by-step instructions make any repair a snap! Everything from a simple tune-up to a major engine overhaul are included in these handy manuals. The electrical wiring diagrams are great too.

Haynes Repair Manual ... [RBK7072 \\$21.94](#)

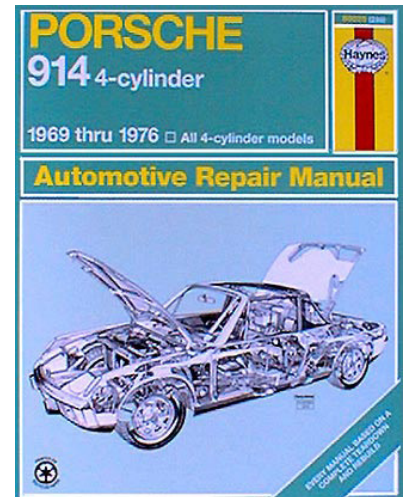

914 Tech Specs Reprint

Tech Specs are just that - every technical specification you can think of! Published by the factory, Tech Specs also gives you production number information. Please specify year and model when ordering. We stock all model and year spec books.

914 Tech Specs Reprint ... [BWKD422 221 \\$25.00](#)



TECH TIPS 700

A COMPLETE TECHNICAL GUIDE
TO THE VW-PORSCHE 914



BY
GEORGE A. HUSSEY, IV

How To Buy A 914

Don't be without this 40 page guide when you go to purchase your new 914. Includes heavy model descriptions, price guide, ID numbers, blow by blow examination guide ... even how to negotiate with the owner! It's the first draft and has no pictures but we guarantee it's the best 914 buying guide on the market.

How to Buy a 914 ... [BTC1018 \\$16.50](#)

Tech Tips 700

By Dr. 914. Newly printed third edition, Tech Tips 700 is the bible when it comes to guides or manuals to operate and maintain your Porsche 914. This little red book has been hailed by 914 owners as a must have companion to their beloved cars. Road & Track magazine says that no 914 owner should be without it.

Add an extra buck and Dr. 914 will personally sign your book!

Tech Tips 700 ... RBK 7074 \$19.95

914-6 Conversion Guide

Everyone's dream is to install the powerful "big six" into their 914. Don't dream, do it! But read this handy guide first. Find out what are you getting yourself into!

Conversion Guide
... [BTC 1013 \\$16.50](#)

HOW TO CONVERT A 914/4 TO A 914/6

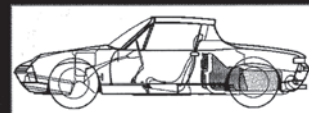

What you are getting yourself into.
by George A. Hussey IV



Bosch Fuel Injection Book

Finally! The authoritative manual on Bosch Fuel injection. This is the only book that fully explains all aspects of these Bosch systems: Motronic, L-Jetronic, LH-Jetronic, LH-Motronic, D-Jetronic, K-Jetronic, KE-Jetronic, and KE-Motronic. You will find specific information on the newest KE-Motronic and LH-Motronic systems that is not available from any other source.

Bosch Fuel Injection Book
... [BBOSCH \\$35.00](#)

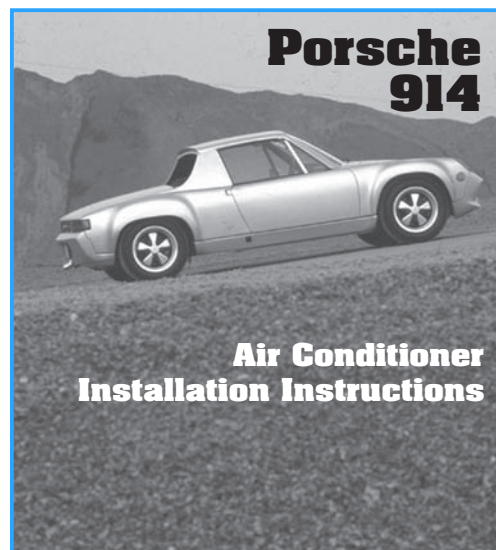

Air Conditioning Installation Manual

Available for VPC or DPD brand A/C systems, this manual completely details installation and shows parts illustration explosions with numbers. One cannot install AC without it.

Air Conditioning Installation Manual
... [BTC 1001 \\$16.50](#)

AUTOMOBILE ATLANTA
PORSCHE EXPERTS

How to Buy a 914

BY GEORGE A. HUSSEY, IV
-DR. 914-

AUTOMOBILE ATLANTA
PORSCHE EXPERTS
808 SOUTH MARIETTA HWY
MARIETTA, GA 30060
TECH-LINE 17701 437-2844

Copyright©1992 by George Hussey, IV
All rights reserved including the right of reproduction in whole
or in any part without permission from the publisher.

ACCESSORIES

Dr. 914 Tech Series

Great "How To" advice on solving the mysterious 914 quirks.

- Battery Area Maintenance ... [BTC 1003 \\$5.50](#)
- Valve Adjust ... [BTC 1040 \\$11.00](#)
- Detailing Procedure ... [BTC 1043 \\$3.30](#)
- AC Installation VPC or DPD ... [BTC 1001 \\$16.50](#)
- Clutch Tube Repair ... [BTC 1008 \\$5.50](#)
- Non-Starting Procedure ... [BTC 1015 \\$11.00](#)
- Starter Circuit Diagnosis ... [BTC 1005 \\$5.78](#)
- 2.0 Rebuild Tips ... [BTC 1014 \\$5.50](#)
- Clutch Replacement Guide ... [BTC 1007 \\$11.00](#)
- Clutch Cable Install ... [BTC 1006 \\$11.00](#)
- Fuel Pump Relocation ... [BTC 1017 \\$5.50](#)

- Windshield Replacement ... [BTC 1041 \\$5.50](#)
- Oil Galley Plug Replacement ... [BTC 1020 \\$5.50](#)
- Push Rod Tube Seal ... [BTC 1022 \\$5.50](#)
- Rear Caliper Rebuild ... [BTC 1023 \\$11.00](#)
- Rear Window Replacement ... [BTC 1024 \\$5.50](#)
- 914 Storage Procedure ... [BTC 1028 \\$5.50](#)
- Trunk Hinge Replacement ... [BTC 1034 \\$5.50](#)
- Powerplant Removal & Installation ... [BTC 1021 \\$11.00](#)
- 70-73 Door Glass Adjustment ... [BTC 1011 \\$5.50](#)
- Fuel Injection Operation ... [BTC 1016 \\$11.00](#)
- Oil Cooler Seal Procedure ... [BTC 1019 \\$6.60](#)
- Seat Loop Replacement ... [BTC 1027 \\$5.50](#)
- **Dr. 914's "How to Buy a 914" ... [BTC1018 \\$16.50](#)**

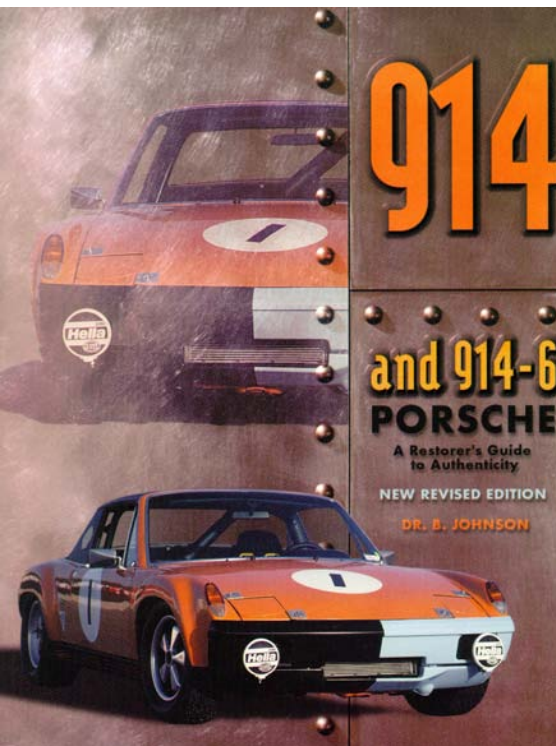
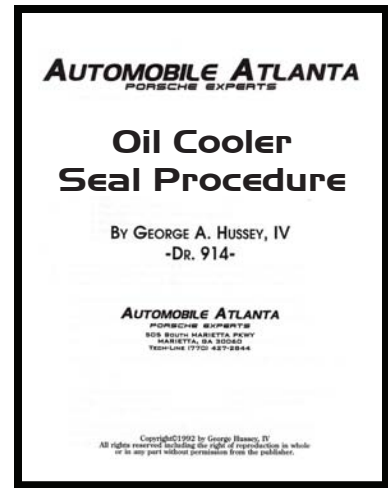
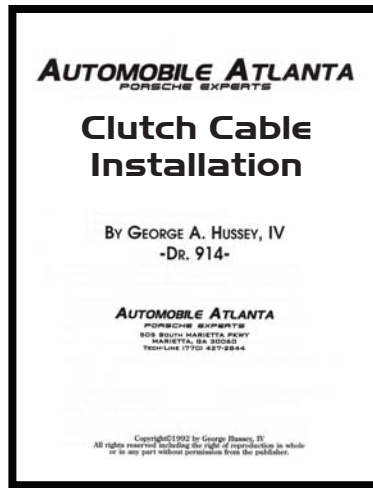
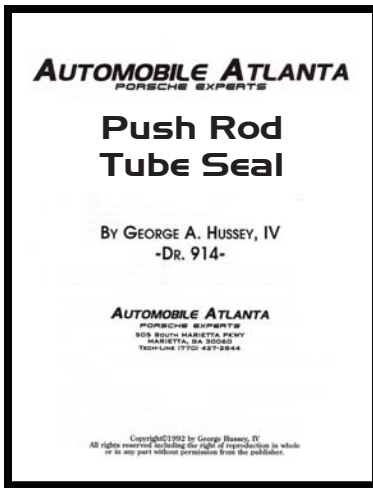

914 Restoration Guide To Authenticity

If you are looking for a source to assist you in restoration, purchase, or authentication of your Porsche, this series is for you. Fun, easy to read guides are filled with photographs to help your search and authenticate your restoration. Restoration guides also include vehicle identification numbers, engine and chassis numbers, and paint and interior trim codes to ease your restoration and insure originality.

Restoration Guide to Authenticity
... [RBK1071 \\$28.32](#)

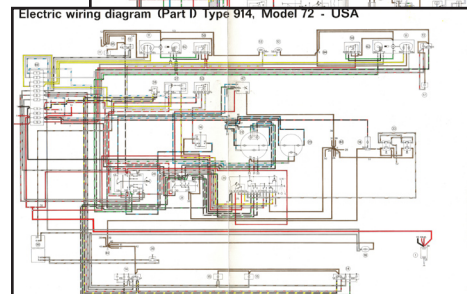
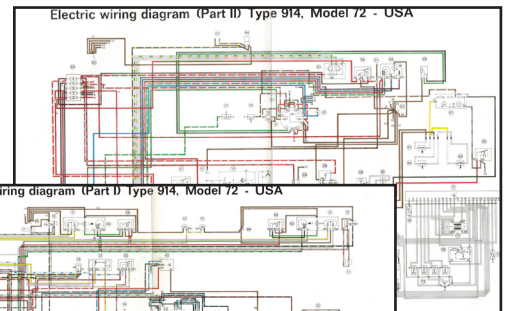

Color Wiring Diagrams

Beautiful reprint of the original wiring diagram. Full color. Chase those bad circuits! Please specify year.

Color Wiring Diagrams ... [BTC1012 \\$22.00](#)

914 Owners Manuals

Original equipment with a new 914, these owners manuals offer a wealth of information on how to operate you 914 as well as technical data. A must for the concours enthusiast.

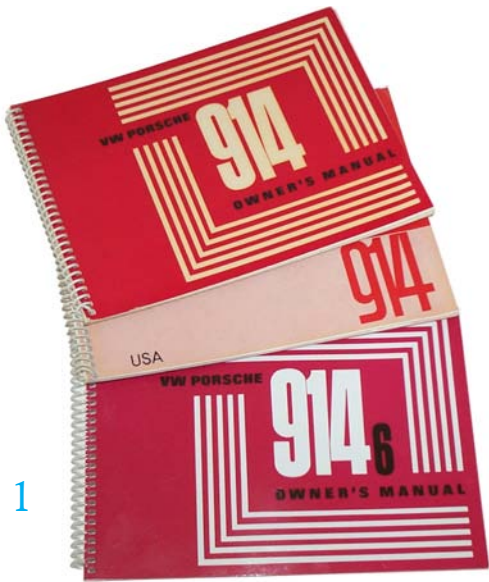

1

1. Owners Manuals:

- 70 914 ... [GWKD 462 020 \\$77.23](#)
- 70 914-6 ... [GWKD 462 120 \\$99.50](#)
- 71 914 ... [GWKD462 620 \\$112.40](#)
- 71 914-6 ... [GWKD 462 720 \\$77.23](#)
- 72 914 ... [GWKD 463 120 \\$62.51](#)
- 72 914-6 ... [GWKD 463 210 \\$77.23](#)
- 73 914 ... [GWKD 464 520 \\$77.23](#)
- 74 914 ... [GWKD 465 220 \\$77.23](#)

75 914 ... [GWKD 466 020 \\$77.23](#)

76 914 ... [GWKD466923 \\$150.00](#)

2. Embossed Owners Manual Cover

... [GWWM 390 100 \\$14.95](#)

3. Maintenance Record (70-73)

... [GWKD 430 000 \\$29.50](#)

4. 914 Tech Specs Reprint

... [BWKD 422 221 \\$25.00](#)



2

3



4

Need detailed technical assistance?
Call us anytime at
(770) 427-2844



24 Hour Lemans 1970 Poster

Great reprint of the original. Won't last long before Porsche pulls the plug on this fantastic poster. 19.75X27.5 inches.

1970 24 Hours of Lemans Poster ... [RPS23999 \\$32.94](#)

Marathon de la Route Poster

... [RML1048 \\$32.94](#)

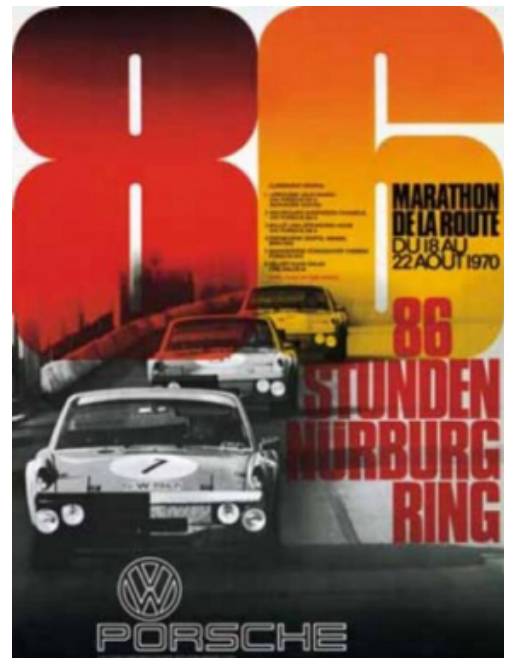

Reproduction 5-Speed Shift Knob



Great reproduction of the factory original. In keeping with the factory tradition we are proud to offer this beautiful factory-look shift knob, which duplicates the original long discontinued Porsche original but with a billet aluminum shift pattern insert! Manufactured from high strength delrin plastic the knob fits all 911 1965-71, 912 1965-76 and 914 1970-76. This knob is so good that it will pass for concours application as the judges will appreciate your effort at factory tradition!

Reproduction 5 speed knob

... [B901 424 014 00 \\$74.50](#)

Shift Knob Crush Sleeve (to install knob)

... [B999 532 001 00 \\$4.50](#)

HARD PARTS

Here, Automobile Atlanta is truly unique! The geniuses of the junk yard have accumulated a selection of used parts, dating back to the late 1970s. These parts will save you lots of money when shopping. Of course, every part is carefully selected, cleaned and checked to ensure proper functioning.

We also specially cut body parts to easily repair your worst collision or rust problem. Since we have repaired many rusty or wrecked Porsches, we know exactly what you need!

When you visit Atlanta and tour our facility, you will be amazed at the number of parts we have packed into our warehouse, just to assure you prompt delivery.

Finally, if you don't see it, we have it! Although this catalog is extensive, it would be impossible to list our vast inventory here. A brief Description is all we need to rush you that rare part. Just call!



WE BUY DERELICT 914s! SELL US YOURS!

914 HARD PARTS

Description	Part Number	Gen.	Repl.	Used	Rep./Reb.
1 Oil Pressure Sending Boot	999 659 009 40	\$8.65	--	--	--
2 Oil Pressure Switch	911 613 571 01	\$12.50	\$10.40	--	--
3 Reducing Thread Screw	900 101 175 01	\$8.47	--	--	--
4 Seal Ring	900 123 140 30	\$1.00	--	--	--
5 Threaded Bushing	999 504 062 02	\$31.94	--	--	\$7.00
6 Radial Seal Ring	999 113 057 52	\$24.92	\$17.60	--	--
7 Stud For Engine Support	999 061 056 02	\$3.50	--	--	--
8 Oil Line O-ring	900 123 007 30	\$1.00	--	--	--
9 Oil Temp Sending Unit	901 641 632 00	\$31.39	\$26.57	--	--
10 Gasket For Breather	930 107 791 02	\$5.81	\$3.80	--	--
11 Stud Bm8x35 For Crankcase Half -R	999 061 010 02	\$11.50	--	--	--
12 Intermediate Shaft Seal Cover	930 105 198 01	\$2.89	\$1.80	--	--
13 Crankcase With Studs	901 101 912 00	\$6,837.47	\$6,655.00	\$1,500.00	--
14 Threaded Bushing	999 504 062 02	\$31.94	\$7.00	--	--
15 Screwset A16 On Crankcase	900 136 013 02	\$9.34	--	--	--
16 Seal Ring	900 123 011 30	\$1.00	\$1.00	--	--
17 Oil Return Tube Seal O-ring	999 701 112 40	\$2.42	--	--	--
18 Return Tube	901 107 351 01	\$28.97	\$16.22	--	\$25.30*
19 Oil Strainer Gasket	930 101 391 01	\$7.30	\$4.00	--	--
20 Complete Oil Strainer	930 107 314 00	\$146.71	\$86.62	--	--
21 Oil Strainer Cover	930 101 902 00	\$73.00	\$47.46	\$20.00	\$12.50
22 Seal Ring	900 123 011 30	\$1.00	\$1.00	--	--
23 Oil Galley Plug	911 107 176 03	\$24.55	\$10.40	--	--
24 Breather Cover, Complete	901 107 073 02	\$40.75	\$28.87	\$20.00	--
25 Oil Temp. Regulator	901 107 751 00	--	--	\$75.00	--
26 Seal Ring	999 707 314 40	\$7.78	\$4.40	--	--

*collapsible

Tech Tip 1: The 914-6 engine is virtually identical to the 911 engine of the same year. Both will bolt directly into your 914. Since Porsche designed and marketed such a six cylinder car, (the 914-6), the six conversion is a worthwhile, satisfying venture. However, **BEWARE!** The attachment pieces (such as the oil tank, the sheet metal, engine mounting, and exhaust) are expensive. If you want to know more about it, consult the 914-6 conversion guide.

914 & 914-6 Engine

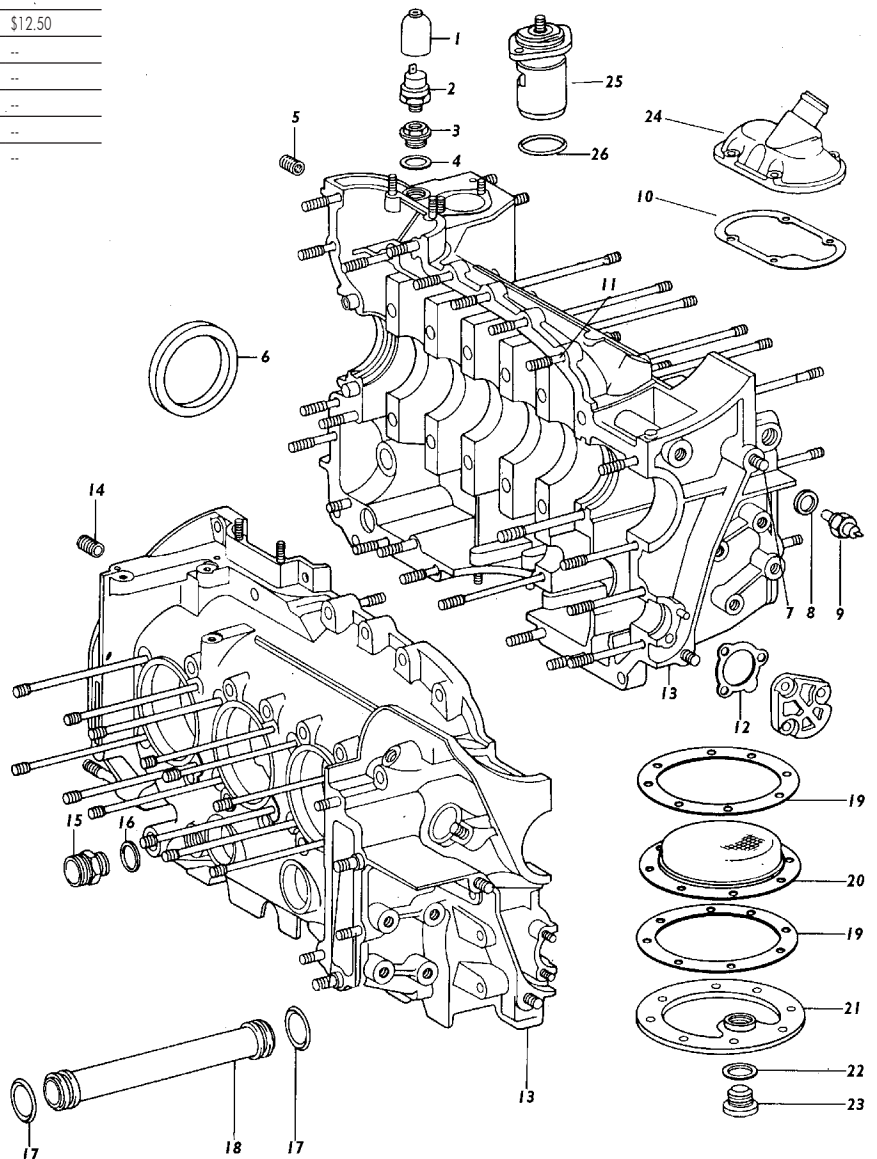

Tech Tip 2: You can spend thousands "hot-rodding" your 914-4 and still not match the power of a stock 914-6.

Tech Tip 3: If your 914-6 oil return tubes are leaking, there is no need to dismantle the cylinder heads and cam housings. Excellent collapsible return tubes are available in the aftermarket. Installation is a snap.

- Parts that are replacement, used or reproduction are not approved, guaranteed, or warranted by Porsche; use of unapproved parts may negate the factory warranty, or alter safety, emission, aerodynamics, or fuel consumption characteristics.

- All rebuilt parts require an exchange. A core charge will be added to the purchase price and refunded when your core is returned in a timely manner.

- All parts are prefixed with a G (Genuine, or Factory), R (Replacement, or Aftermarket), U (Used), or B (Rebuilt or Reproduction).

914-6 Engine

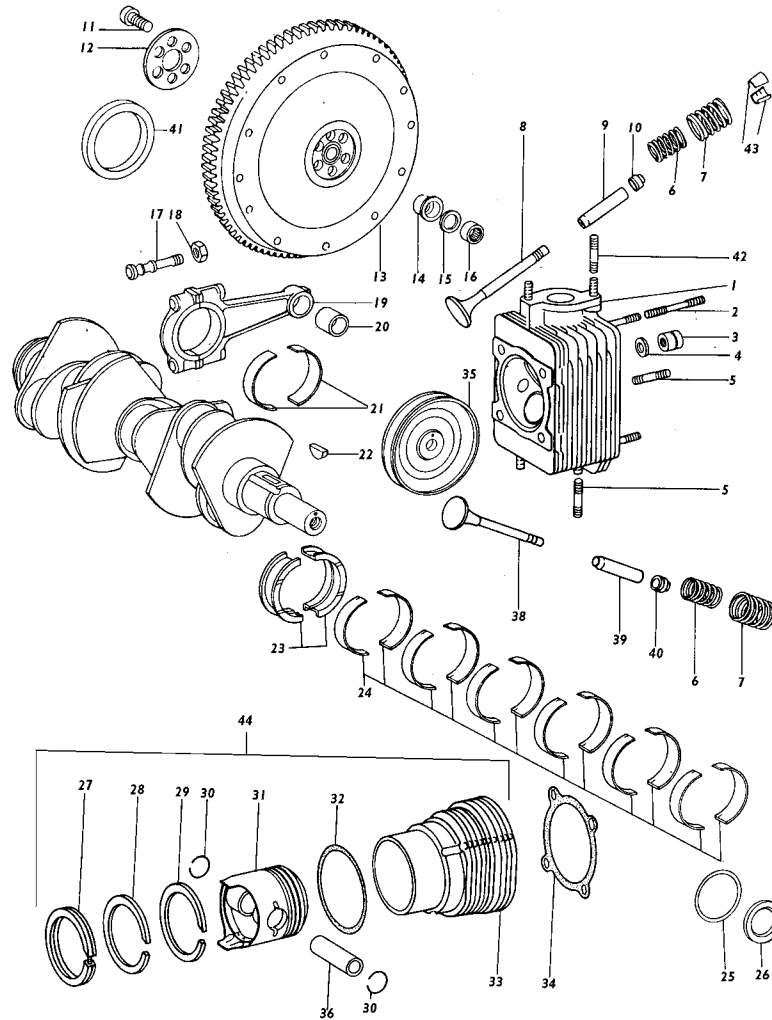

Description	Part Number	Gen.	Repl.	Used	Rep./Reb.
1 Cylinder Head Complete	901 104 036 02	\$1,502.38	--	\$600.00	\$330.00
2 Stud Bm 8x50	999 062 041 02	\$3.50	--	--	--
3 Cylinder Head Nut	901 104 382 00	\$4.09	--	--	--
4 Washer	999 031 061 02	\$9.92	--	--	--
5 Stud 8x20MM	999 062 006 02	\$3.50	--	--	--
6 Valve Springs, Inner & Outer	901 105 901 50	\$75.49	\$19.50	--	--
7 Valve Springs, Inner & Outer	901 105 901 50	\$75.49	\$19.50	--	--
8 Intake Valve	901 105 407 00	\$124.00	\$36.90	--	--
9 Intake Valve Guide	930 104 321 50	\$13.12	\$5.77	--	--
10 Valve Stem Seal	928 104 193 12	\$6.00	\$5.50	--	--
11 Flywheel Bolt	901 102 171 00	\$16.81	\$9.75	\$4.00	--
12 Flywheel Plate	901 102 162 04	\$49.23	\$27.44	--	--
13 Flywheel Complete	901 102 026 01	\$852.12	\$395.00	\$300.00	\$200.00
14 Complete Bushing Set	901 102 025 01	\$45.71	\$16.44	--	--
15 Complete Bushing Set	901 102 025 01	\$45.71	\$16.44	--	--
16 Pivot Shaft Bearing	901 102 025 01	\$45.71	\$16.44	--	--
17 Connecting Rod Screw	901 103 172 00	\$24.78	\$10.50	--	--
18 Connecting Rod Nut	901 103 173 00	\$4.71	\$2.14	--	--
19 Connecting Rod Complete	901 103 011 25-32	\$310.52	--	\$150.00	\$110.00
20 Connecting Rod Bushing	911 103 132 00	\$23.75	\$4.60	--	--
21 Rod Bearing Set	901 103 141 00	\$16.97/ea.	\$69.98/set	--	--
22 Woodruff Key	901 102 147 00	\$3.77	--	--	--
23 Crankshaft Bearing Shell I	901 101 131 00	\$59.69/ea.	\$34.60/ea.	--	--

Description	Part Number	Gen.	Repl.	Used	Rep./Reb.
24 Crankshaft Bearing Shell II-VI	901 101 132 00	\$33.68/ea.	\$161.70/set.	--	--
25 O-ring R50x4PAB/769	900 174 041 40	\$7.02	--	--	--
26 Radial Seal Ring 30x50x10	999 113 290 41	\$27.48	\$8.23	--	--
27 Piston Ring Set Mahle	901 103 901 02	\$54.65/ea.	\$155.92/set	--	--
28 Piston Ring Set 80.5	901 103 901 52	\$54.65/ea.	\$155.92/set	--	--
29 Piston Ring Set 81	901 103 901 62	\$59.32/ea.	\$155.92/set	--	--
30 Piston Clip	900 178 002 00	\$2.00	--	--	--
31 Piston Complete (2nd Oversize 81)	901 103 038 60	\$244.85/ea.	--	\$150.00/ea	--
Piston Complete (1st Oversize 80.5)	901 103 038 50	\$207.12/ea.	--	\$150.00/ea	--
32 Cylinder Base Gasket	901 104 191 00	\$7.03	--	--	--
33 Cylinder Group 5	901 103 903 01	\$1,066.81/set	\$2,252.25/set	\$200.00/ea	--
33 Cylinder Group 6	901 103 903 02	\$1,109.27	--	\$200.00/ea	--
34 Cylinder Head Gasket	901 104 391 00	\$19.40	\$10.39	--	--
35 Crankshaft Pulley	911 102 017 50	\$153.60	--	\$80.00	--
36 Piston Pin	901 103 323 00	\$33.09	--	--	--
38 Exhaust Valve	901 105 408 50	\$187.14	\$93.55	--	--
39 Exhaust Valve Guide 1st O/s	930 104 321 50	\$13.12	\$9.20	--	--
Exhaust Valve Guide 2nd O/s	901 104 321 61	\$21.18	\$9.24	--	--
40 Valve Seal	928 104 193 12	\$6.00	\$5.50	--	\$2.00
41 Radial Seal Ring	999 113 057 52	\$24.92	\$17.60	--	--
42 Stud 8x25	900 061 008 02	\$3.65	--	--	--
43 Valve Cone	901 105 417 00	\$2.00	\$1.00	--	--
44 Compl. Piston & Cyl. Set (See #27,31)	901 103 903 01	\$1,066.81/ea.	\$2,252.25/set	\$200.00/ea	--

914 HARD PARTS

Description	Part Number	Gen.	Repl. Used	Rep./Reb.
1 Upper Camshaft Housing Cover	901 105 115 03	\$308.35	\$286.00	\$25.00 \$75.00
2 Gasket For Housing Cover	930 105 194 04	\$17.67	\$9.81	-- --
3 Gasket For Lower Housing Cover	930 105 195 06	\$10.79	\$34.65	-- -- Complete Kit
4 Lower Camshaft Housing Cover	930 105 116 00	\$484.88	\$90.42	-- \$75.00
5 Washer 8.4 DIN 433-AL	900 031 014 30	\$1.00	\$1.00	-- --
6 Hex Nut M8 DIN 985-8 Verz	900 084 004 02	\$1.00	\$1.00	-- --
7 Gasket Crankcase & Chain Housing	930 105 193 06	\$4.25	\$3.46	-- --
8 Left Chain Housing Cover Gasket	930 105 191 03	\$9.88	\$2.47	-- --
9 Right Chain Housing Cover Gasket	930 105 192 03	\$10.12	\$4.60	-- --
10 Clamping Sleeve 5x24	N 013 289 1	\$2.00	--	-- --
11 Camshaft	901 105 133 00	\$1,796.53	\$750.70	-- --
12 Valve Rocker, Complete	930 105 043 00	\$80.39	\$28.87	-- --
13 Nut	999 034 005 00	\$2.10	\$1.16	-- --
14 Adjusting Screw, Complete	901 105 370 02	\$29.61	\$9.35	-- --
15 Nut	901 105 376 02	\$5.37	\$5.48	-- --
16 Valve Rocker Shaft	901 105 342 04	\$41.96	\$13.86	-- --
17 Bushing	901 105 344 02	\$2.94	\$2.75	-- --
18 Cheese Head Screw	999 067 008 00	\$8.95	\$5.04	-- --
19 Timing Chain	993 105 529 00	\$91.17	\$40.42	-- --
20 Slide Rail	911 105 222 05	\$9.00	\$6.00	-- --
21 Bearing Mounting For Intermediate Shaft	993 101 137 00	\$19.60	\$15.01	-- --
22 Intermediate Shaft Bearing	993 101 135 00	\$19.51	\$16.10	-- --
23 Chain Housing Complete, Right	930 105 062 01	--	\$625.00	\$200.00 --
Chain Housing Complete, Left	930 105 061 02	--	\$625.00	\$200.00 --
24 Cover For Chain Housing, Left	930 105 063 01	\$109.92	\$87.70	\$59.00 --
25 Cover For Chain Housing, Right	930 105 064 02	\$176.28	\$78.50	\$55.00 --
26 Chain Adjuster Housing	930 105 053 00	\$445.49	\$225.00	\$85.00 --
27 to 40 Chain Tensioner Rebuild Kit	911 105 901 01	\$75.00	--	-- --

Tech Tip 4: 930 exhaust valve covers permanently eliminate the poorly sealing stock valve covers, although the installation may involve lowering each side of the engine.

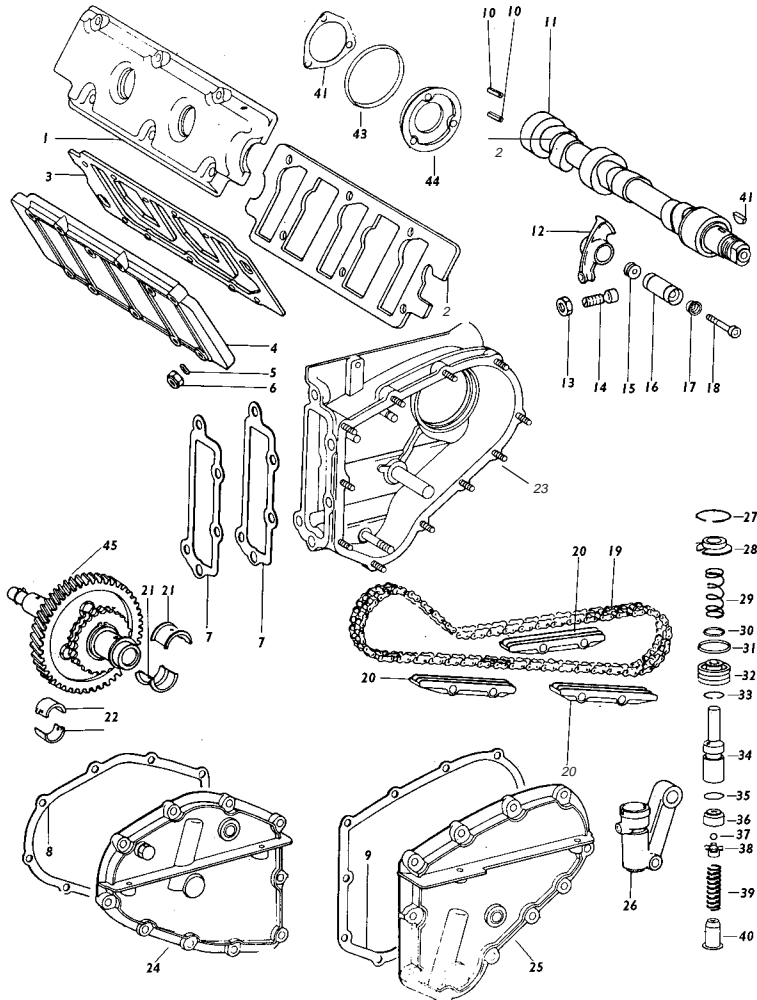

914-6 Engine

914-6 Engine

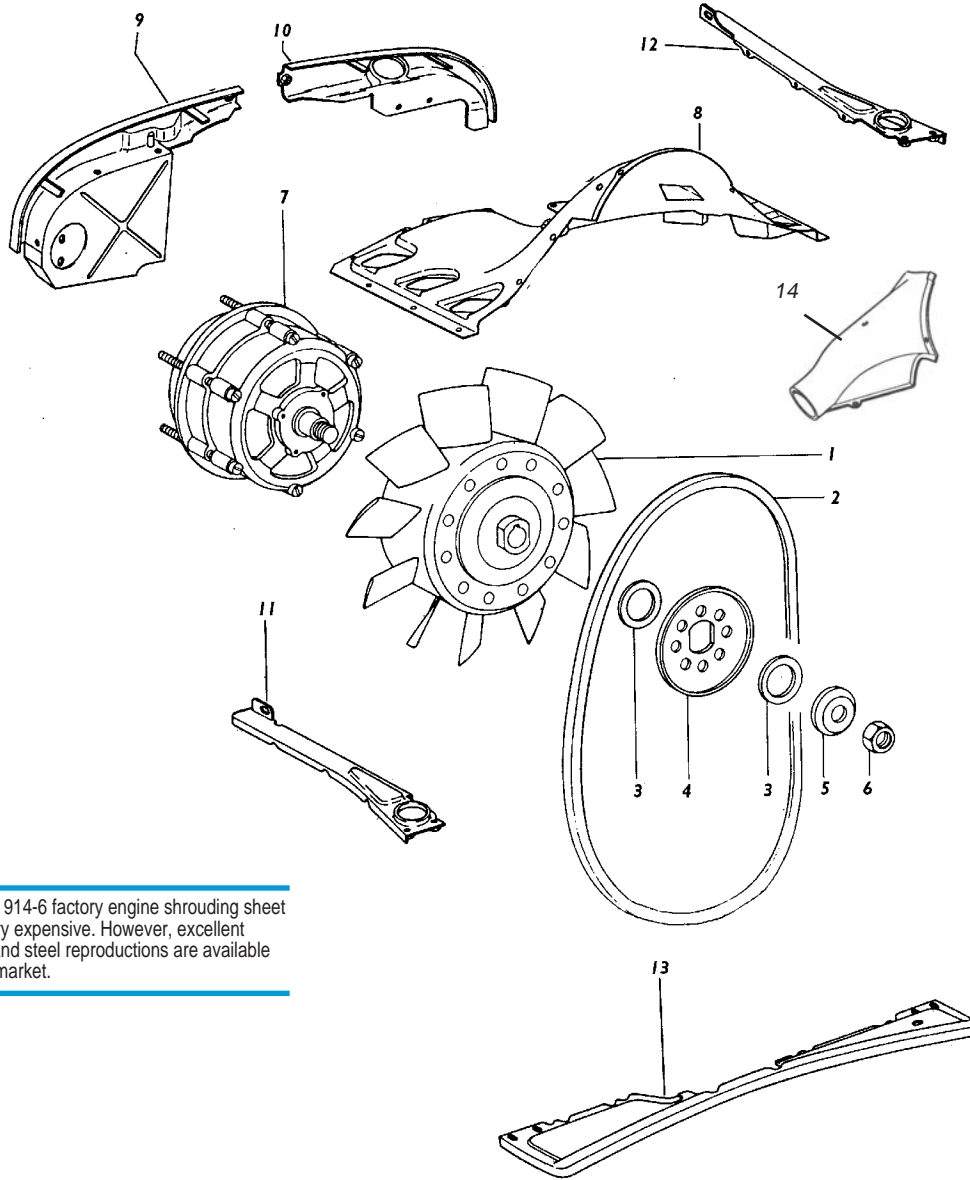

Tech Tip 8: 914-6 factory engine shrouding sheet metal is very expensive. However, excellent fiberglass and steel reproductions are available in the aftermarket.

Description	Part Number	Gen.	Repl.	Used	Rep./Reb.
1 Impellor, Complete	901.106.010.03	\$679.75	\$548.00	\$300.00	--
2 V-belt 9.5x710	999.192.176.50	\$8.48	\$6.50	--	--
3 Compensating Washer For Sm Pulley	901.150.561.00	\$5.44	\$3.50	--	--
4 Pulley Half	901.603.421.01	\$24.08	\$18.70	\$10.95	--
5 Clamping Cap For Bosch Generator	901.603.427.01	\$4.49	--	--	--
6 Hexagon Nut	900.078.005.01	\$6.50	--	--	--
7 Alternator 770w (With Core)	911.603.118.X	\$711.64	\$369.00	\$150.00	\$278.00*
8 Upper Air Guide Plate, Complete	911.106.901.00	\$635.55	--	\$450.00	--
9 Engine Cover	901.106.076.00	\$355.76	--	\$270.00	\$192.00
10 Engine Cover	901.106.075.00	\$495.00	--	\$173.00	\$165.00
11 Engine Cover, Comp. Cylinders 1-3	901.106.073.00	\$363.12	--	\$192.50	\$165.00
12 Engine Cover, Comp. Cylinders 4-6	901.106.074.00	\$363.12	--	\$192.50	\$165.00
13 Engine Cover	901.106.817.00	\$495.00	--	\$200.00	\$165.00
14 Shroud Duct	901.106.321.02	\$43.55	--	\$35.00	--

*Core charge required.

G = Genuine • R = Aftermarket / Replacement •
U = Used • B = Rebuilt or Reproduction

914 HARD PARTS

Description	Part Number	Gen.	Repl.	Used	Rep./Reb.
1 Oil Dipstick	901 107 770 40	\$72.50	--	\$50.00	--
2 Connect Hose Crank Case - Oil Tank	999 236 008 50	\$99.50	\$65.00	--	--
3 Connect Hose Oil Tank - Air Cleaner	999 236 008 50	\$99.50	\$65.00	--	--
4 Oil Hose Crank Case To Camshaft, L	901 107 347 01	\$26.31	\$16.75	--	--
5 Oil Hose Crankcase - Camshaft, R	901 107 348 00	\$30.70	\$18.15	--	--
6 Seal Ring For Breather Socket	901 107 695 40	\$48.85	--	--	--
7 Hose Clip	999 512 356 02	\$3.72	\$1.73	--	--
8 Seal Ring For Filler Socket	901 107 696 40	\$23.74	--	--	--
9 Rubber Sleeve For Filler Socket	901 107 691 10	\$38.76	--	--	--
10 Clamp	999 512 073 02	\$6.80	--	--	--
11 Oil Filler Neck	901 107 640 40	\$475.00	--	--	\$225.00
12 Seal Ring	901 201 272 00	\$4.68	--	--	--
13 Oil Cap	901 201 271 00	\$26.50	\$15.00	\$7.00	--
14 Hexagon Nut	NO 211 941	\$1.00	--	--	--
15 Washer	900 151 008 02	\$1.00	\$1.00	--	--
16 Washer	901 107 693 01	\$6.29	--	--	--
17 Washer	901 107 692 00	\$6.29	--	--	--
18 Oil Tank	901 107 005 40	\$1,750.00	--	--	\$950.00
19 Oil Line	901 107 820 02	\$450.50	--	--	--
20 Rubber Sleeve For Hose	999 702 089 50	\$4.50	--	--	--
21 Oil Filter	901 107 203 09	\$18.21	\$14.43	--	--
22 Cheese Head Screw	NO 147 492	\$1.00	--	--	--
23 Spring Washer	NO 122 265	\$1.00	--	--	--
24 Console	901 107 025 00	\$285.50	--	--	\$150.00
25 O-ring	999 701 100 50	\$5.88	--	--	--
26 Circlip	901 107 281 00	\$7.04	--	--	--
27 Seal Ring For Oil Filter	901 107 291 00	\$57.41	--	--	--
28 Clamp	999 511 076 02	\$7.18	--	--	--
29 Seal Ring	901 107 679 10	\$5.24	--	--	--
30 Hexagon Nut	900 183 006 02	\$4.00	--	--	--
31 Hose	901 107 821 00	\$98.11	\$66.00	--	--
32 Rubber Sleeve To Hose	999 702 132 50	\$6.00	--	--	--
33 Hose	901 107 710 04	\$219.28	\$104.00	--	--
34 Clamp	999 511 076 02	\$7.18	--	--	--
35 Bolt, Hx Head	999 072 005 09	\$2.09	\$1.15	--	--
36 Bracket	901 107 084 00	\$17.81	--	--	--
37 Clamp For Suction Hose	999 511 077 02	\$7.54	--	--	--
38 Hose	901 107 823 03	\$215.95	\$104.00	--	--
39 Seal Ring	999 704 172 50	\$5.50	\$2.95	--	--
40 Seal Ring	999 704 173 50	\$6.60	\$3.30	--	--
41 Oil Cooler	901 107 059 01	\$1,310.00	--	\$950.00	--
42 Temp Sensor Socket	901 107 375 00	\$23.27	\$8.25	--	--
43 Cutting Ring	NO 208 251	\$4.65	--	--	--
44 Cap Nut	900 104 003 02	\$9.18	\$6.00	--	--
45 Oil Pump	901 107 002 06	\$912.94	--	--	--
46 Oil Pump Seal	999 704 013 50	\$5.50	\$2.95	--	--

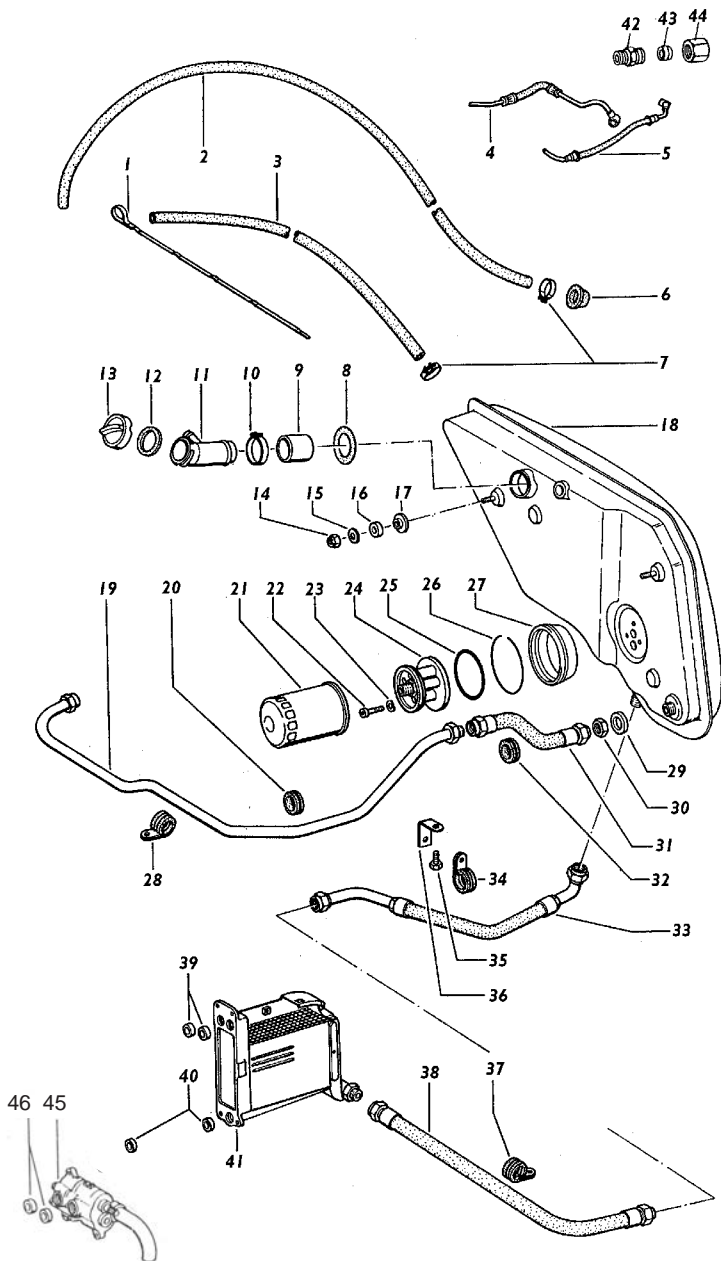

Tech Tip 10: The 914-6 oil tank is made to fit perfectly in the front of the left rear quarter panel cavity. All 914s are stamped to mount this oil tank (look at the stampings above the relay board in the engine compartment). 911 oil tanks will not fit. Aftermarket 914-6 tanks have been made to fit the cavity and lessen the expense when converting from a four to a six.

914-6 Engine

914 & 914-6 Engine

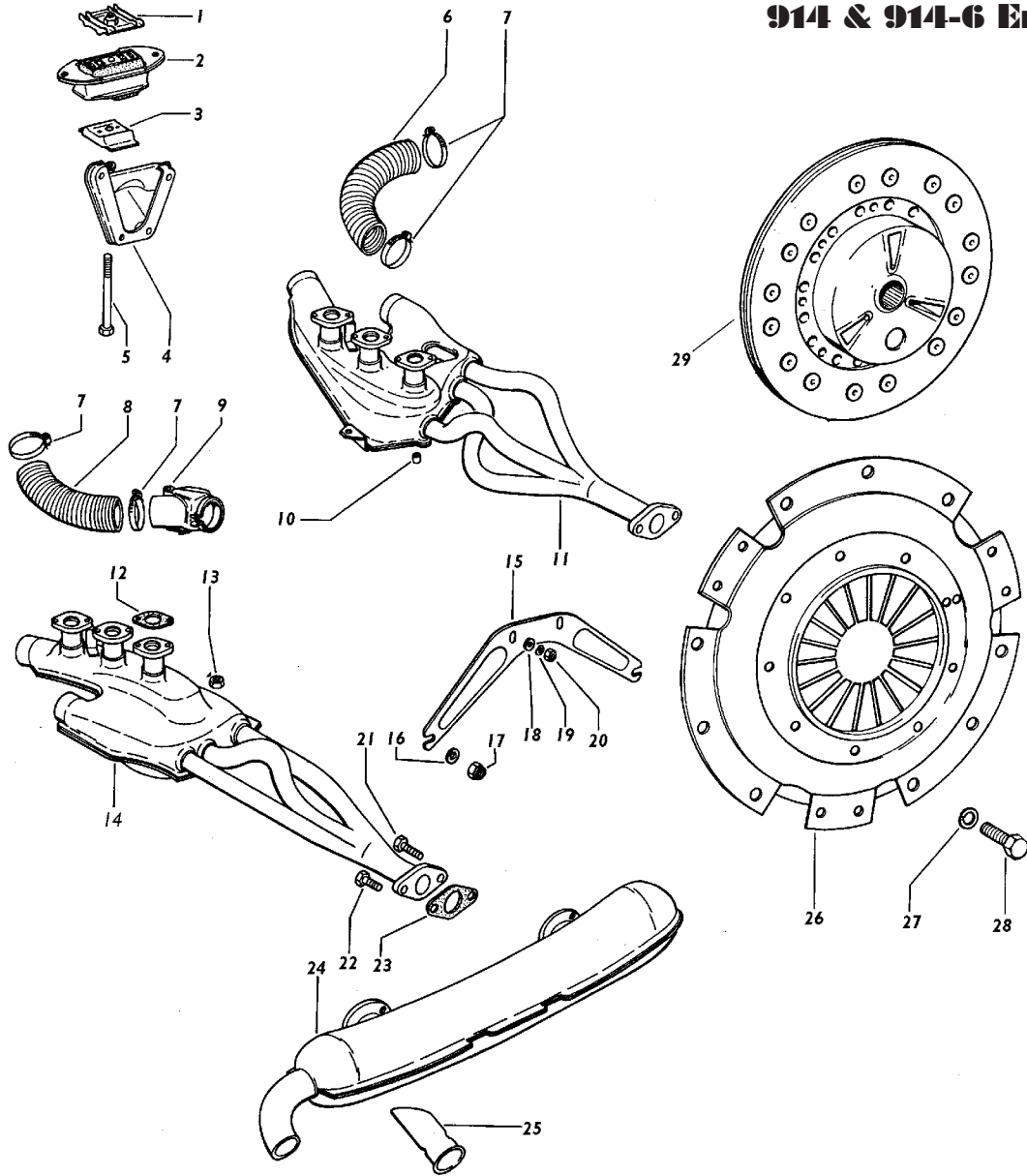

Description	Part Number	Gen.	Repl.	Used	Rep./Reb.	Description	Part Number	Gen.	Repl.	Used	Rep./Reb.
1 Upper Supporting Plate	914.375.057.00	\$362.00	--	\$150.00	\$192.00	18 Washer B8.4 Din 9021-A1	900.151.030.30	\$2.88	\$1.00	--	--
2 Engine Mounting	914.375.049.00	\$399.00	--	\$138.00	--	19 Spring Washer	900.028.024.01	\$1.00	\$1.00	--	--
3 Lower Supporting Plate	914.375.158.00	\$362.00	--	\$150.00	\$192.00	20 Hexagon Nut M8	900.076.025.02	\$2.15	\$1.15	--	--
4 Complete Console	901.115.012.00	\$675.33	--	\$450.00	--	21 Bolt, Hex Hd M10x40	900.074.059.02	\$1.10	\$1.00	--	--
5 Bolt, Hex Hd	914.375.267.00	\$10.95	--	--	--	22 Bolt, Hex Hd M10x32	900.075.148.02	\$1.01	\$1.00	--	--
6 Heating Hose	901.211.196.00	\$35.11	\$16.50	--	--	23 Gasket	901.111.193.00	\$10.59	\$8.75	--	--
7 Clamp (51-72) X9 Ver Z	999.512.349.02	\$4.22	\$2.90	--	--	24 Muffler	901.111.011.11	\$960.50	\$675.50	\$450.00	--
8 Heating Hose 255mm	914.572.154.10	\$46.61	\$14.50	--	\$13.75	25 Tail Pipe	901.111.245.01	\$45.29	\$40.42	--	\$29.50
9 Control Box For Heat Exch. Cyl 1-3	901.211.620.00	\$281.00	\$113.90	--	--	26 Pressure Plate	901.116.011.01	\$211.75	\$159.30	--	\$82.00
10 Nut W/hexagon M.8 Sock	999.085.001.02	\$4.75	\$2.30	--	--	27 Spring Ring B8	900.027.015.02	\$1.00	\$2.00	--	--
11 Heat Exchanger Cyl 1-3	901.211.004.00	\$2,635.00	--	\$1,150.00	--	28 Bolt, Hex Hd M8x15	900.075.104.01	\$1.00	\$1.00	--	--
12 Gasket	901.111.191.01	\$21.70	\$8.91	--	--	29 Clutch Disc	914.116.011.01	\$358.66	\$155.92	--	\$82.00
13 Hexagon Nut M8 Din 934-8 Verz	900.076.025.02	\$2.00	\$1.15	--	--						
14 Heat Exchanger Cyl 4-6	901.211.003.00	\$2,629.73	--	\$1,150.00	--						
15 Muffler Support	901.111.152.00	\$95.56	--	\$25.00	\$40.00						
16 Washer - Muffler To Bracket	900.025.008.09	\$1.00	\$1.00	--	--						
17 Hexagon Nut	999.084.002.02	\$1.96	--	--	--						

* Rebuilt Parts Require A Rebuildable Core

914 HARD PARTS

Description	Part Number	Gen.	Repl.	Used	Rep./Reb.
1 Gasket For Oil Strainer Cover	021 198 031 B	\$6.40	\$4.00/set	--	--
2 Oil Strainer Basket	021 115 175	\$29.50	\$15.55	--	--
3 Cover For Strainer	021 115 181	\$15.43	--	\$10.00	--
4 Oil Drain Plug Washer	NO 138 051	\$2.00	\$1.15	--	--
5 Nut M8	021 115 193 B	\$19.71	--	\$9.50	--
6 Oil Pressure Switch	021 919 081 B	\$14.56	\$9.50	--	--
7 Oil Pump Case	021 115 107 A	\$272.32	--	--	--
8 Gasket For Oil Pump Case	025 115 111 A	\$2.25	--	--	--
9 Oil Filter	021 115 351 A	\$16.70	\$10.79	--	--
10 Gasket Ring 100x109	021 101 341 A	\$5.68	\$2.30	--	--
11 Cylinder 1.7	021 101 301 A	\$220.23/ea.	\$433.12/set	--	--
Cylinder 1.8	022 101 301 A	\$267.50/ea.	\$548.62/set	--	--
Cylinder 2.0	039 101 301 C	\$346.23/ea.	\$606.00/set	--	--
12 Cylinder Head Gasket	021 101 343	--	\$4.62	--	--
13 Exhaust Stud 8mm	NO 144 277	\$9.60	\$6.90	--	--
Exhaust Stud 1.8 8/9	NO 143 979	\$10.07	\$9.60	--	--
Exhaust Stud Oversize 8/10	NO 146 841	\$10.57	\$9.84	--	--
14 Exhaust Nut	039 256 297	\$16.10	\$2.50	--	--
15 Clamp For Cylinder Head Cover	021 101 487	\$18.73	--	\$9.00	--
16 Intake Valve Guide	021 101 403 A	\$30.74	\$5.77	--	--
Intake Valve Guide 1.7, 1.8	021 101 403 A	\$30.74	\$5.77	--	--
Intake Valve Guide 2.0	039 101 403	\$15.07	\$6.48	--	--
Exhaust Guide 1.7,1.8	021 101 417 A	\$39.06	\$3.50	--	--
Exhaust Guide 2.0	039 101 421	\$31.68	\$10.95	--	--
17 Valve Cover Gasket	021 101 481	\$5.37	\$3.50	--	--
18 Cylinder Head Cover	021 101 471	\$49.50	--	\$15.00	--
19 Hex Nut M7	NO 110 077	\$2.28	\$1.37	--	--
20 Spring Washer B7	NO 122 341	\$1.00	--	--	--
21 Stud For Rocker Shaft	021 101 397	\$9.79	--	--	--
22 Stud Am 8x35	NO 144 003	--	\$9.50	--	--
23 Cylinder Head 1.8	021 101 351 S	\$1,149.50	--	\$800.00	\$850.00
Cylinder Head 1.7	021 101 351 B	\$1,028.50	--	\$400.00	\$700.00
Cylinder Head 2.0 1973-74	039 101 351 E	\$1,584.30	--	\$950.00	--
Cylinder Head 2.0 1975-76	039 101 351 G	--	--	\$935.00	--
24 Absorber	021 101 107	\$7.23	\$4.30	--	--
25 Bolt Hex Hd M 10x125x113	021 101 145 B	\$32.05	--	\$18.00	--
26 Cam Plug	113 101 157 C	\$4.83	\$2.40	--	--
27 Stud Am 10x92 For Eng Mounting	NO 145 571	\$15.65	--	\$8.00	--
28 Oil Pipe	021 101 149	\$107.46	--	\$68.50	--
29 Stud For Crankcase	NO 145 561	\$15.60	--	--	--
30 Stud For Crankcase	NO 145 551	\$15.40	--	--	--
31 Stud For Crankcase	NO 144 174	\$8.50	--	--	--
32 Seal Ring For Cover	021 101 269 A	\$9.47	\$6.88	--	--
33 Cover For Oil Pan With Sending Unit	039 101 267	\$74.12	--	--	--
34 Seal Ring C6x10	NO 138 032	\$1.00	--	--	--
35 Bolt Hex Hd M6x10	NO 102 1013	\$2.00	\$1.16	--	--
36 Washer	900 123 007 30	\$1.00	--	--	--
37 Oil Temp Sending Unit	039 919 268	\$57.04	--	--	--
38 Boot For Thermostat Wire	NO 145 421	\$16.50	--	--	--
39 Crankcase	021 101 025 H	\$1,901.15	--	\$650.00	\$385.00
40 Bolt, Hex Hd M8x88	NO 103 732	\$4.39	\$1.15	--	--
41 Seal Inq. 8.2x16	021 101 189	\$1.00	--	--	--
42 Oil Drain Plug Washer	NO 138 051	\$2.00	\$1.15	--	--
43 Oil Drain Plug	021 101 195	\$11.50	--	--	--
44 Oil Baffle Plate Seal	022 101 559	\$18.68	--	\$7.50	--
45 Oil Baffle Plate	022 101 553	\$89.00	--	\$45.00	--
46 Cylinder Head Nut	NO 110 088	\$2.50	\$1.10	--	--
47 Cylinder Head Washer	021 101 457	\$4.20	\$2.31	--	--
48 Oil Pressure Switch Boot	021 119 157	\$32.37	--	--	--
49 Oil Stand	021 115 353 A	\$164.53	--	\$75.00	--
50 Oil Stand Gasket	021 115 359 A	\$3.00	--	--	--

* Rebuilt Parts Require A Rebuildable Core

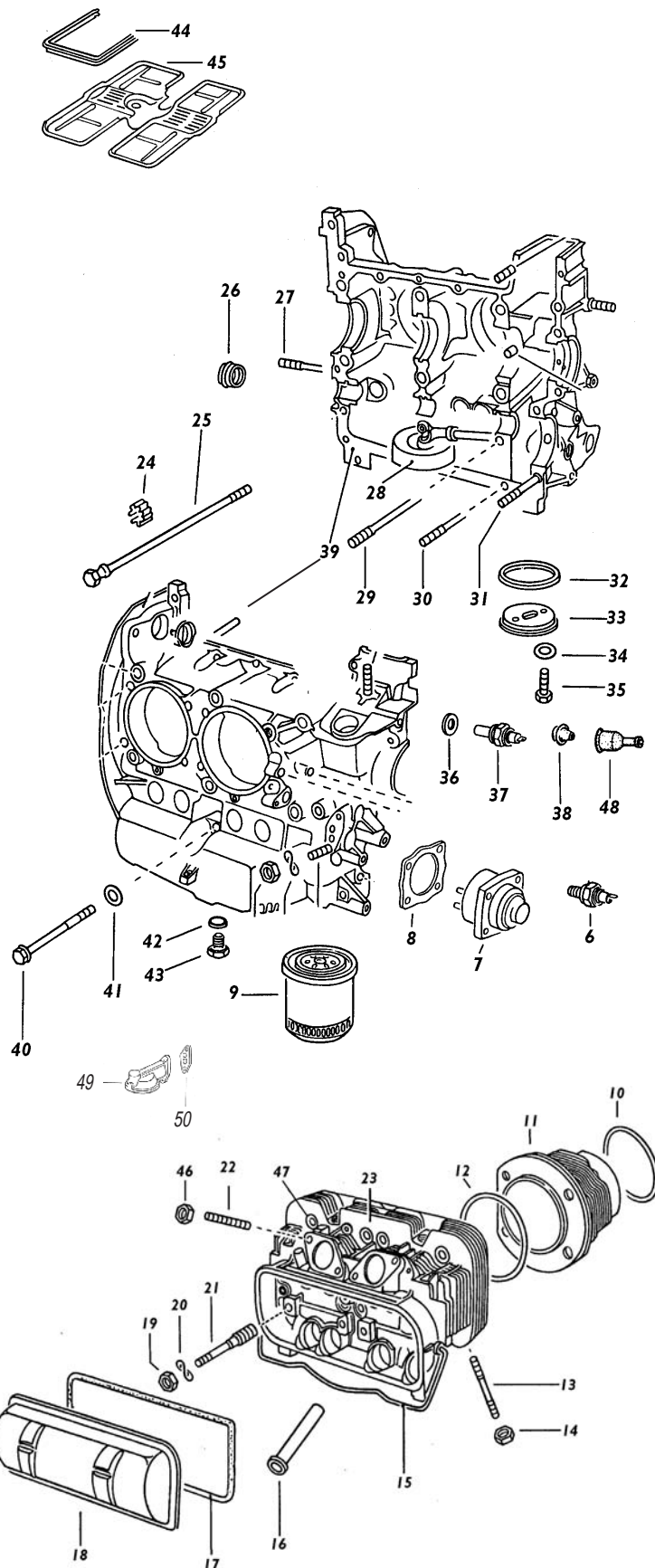
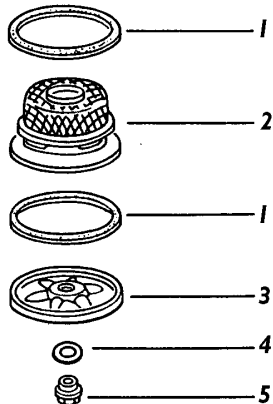

914 Engine

Description	Part Number	Gen.	Repl.	Used	Rep./Reb.
1 Support, Left	039.199.221	\$69.77	--	\$40.00	--
Support, Right	039.199.222	\$70.21	--	\$40.00	--
2 Engine Mount	039.199.231	\$44.79	\$23.83	\$15.00	--
3 Bolt, Hex Hd M8x20 Self Locking	N0.143.291	\$4.36	--	\$2.50	--
4 Engine Mounting Bar	914.375.161.05	\$398.50	--	\$200.00	--
5 Engine Mount, Outboard	914.375.181.00	\$32.50	--	\$27.50	--
6 Bolt, Hex Hd M10x85	N0.104.724	\$4.08	\$2.30	--	--
7 Engine Mounting	914.375.035.00	\$148.05	--	\$55.00	\$45.00
8 Supporting Plate, Lower	914.375.241.00	\$44.40	--	\$20.00	--
9 Engine Carrier	914.375.173.01	\$248.78	--	\$75.00	--
10 Bolt, Hex Hd M10x70	900.074.138.01	\$3.22	\$2.36	--	--
11 Outer Engine Bar Bolts, 1970-72	900.074.181.02	\$3.10	\$2.30	--	--
12 Engine Mount Bolt Nut, M10	900.276.006.02	--	\$1.16	--	--

Tech Tip 22: If your 73-76 shifter moves in your hand upon acceleration and the engine jumps, you need new engine mounts. This is a common problem.

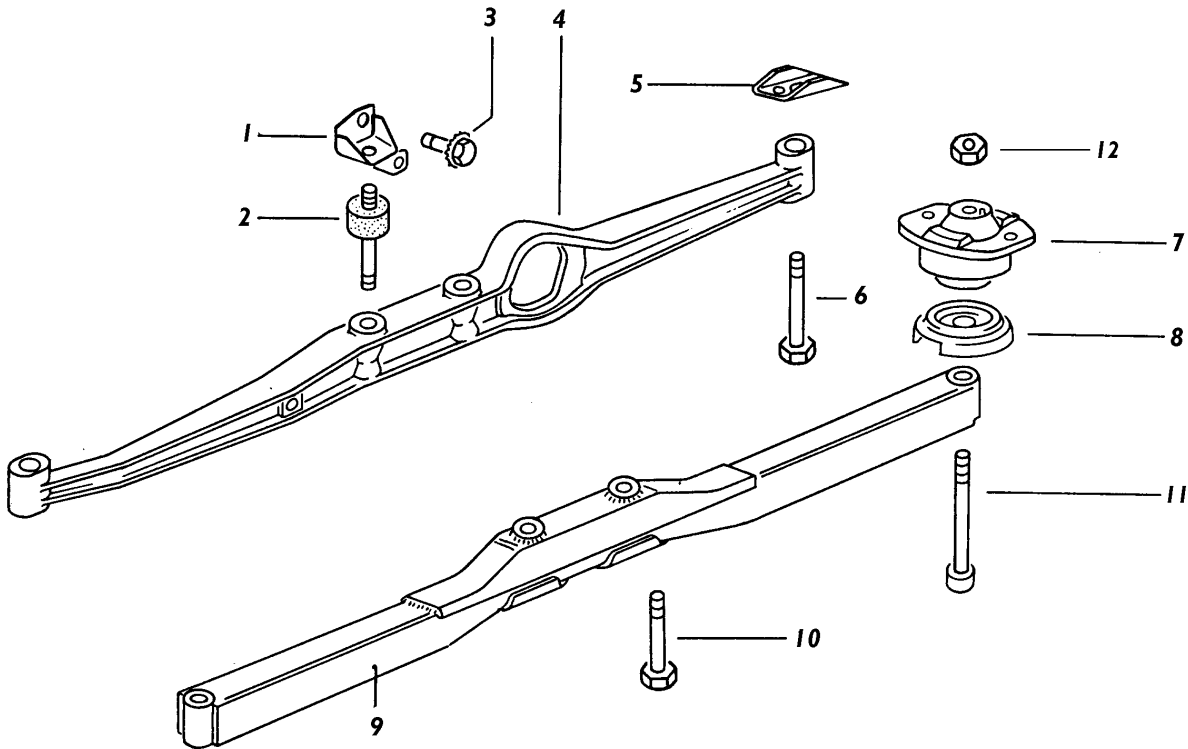

Tech Tip 23: If your 73-76 engine mount bar is bent backwards toward the rear, simply remove the bar, straighten the outboard solid mounts, and reinstall. We suggest reflattening the mounts on a vise or replacing if hopelessly bent.

914 HARD PARTS

914 Engine

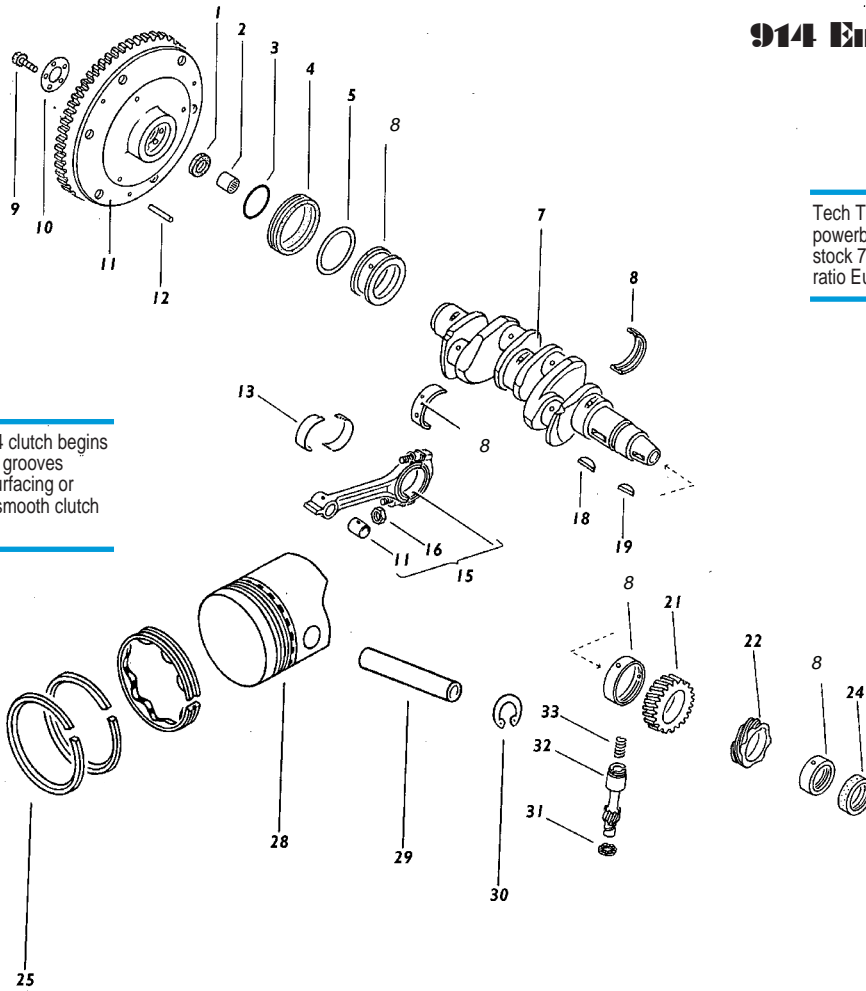

Tech Tip 33: When the 914 clutch begins to slip from wear, it always grooves the flywheel. Flywheel resurfacing or replacement is a must for smooth clutch operation.

Tech Tip 36: To give your 914 2.0 a powerboost when rebuilding, replace the stock 7.6 to 1 ratio pistons with the 8.0 to 1 ratio European type.

Description	Part Number	Gen.	Repl.	Used	Rep./Reb.
1 Feltwasher	111 105 311	\$2.00	\$1.16	--	--
2 Needle Bearing	111 105 313 A	\$8.06	\$5.77	--	--
3 Flywheel O-ring	021 105 279	\$3.93	\$2.20	--	--
4 Rear Mainseal	029 105 245 B	\$49.25	\$15.95	--	--
5 Crank End-Play Shim, 30mm	021 105 281	\$5.89	\$4.60	--	--
Crank End-Play Shim, 32mm	021 105 283	\$5.89	\$4.60		
Crank End-Play Shim, 34mm	021 105 285	\$5.89	\$4.60		
Crank End-Play Shim, 36mm	021 105 287	\$5.89	\$4.60		
Crank End-Play Shim, 38mm	021 105 289	\$5.89	\$4.60		
Crank End-Play Shim, 24mm	021 105 291	\$5.89	\$4.60		
7 Crankshaft 1.7, 1.8	021 105 101	\$963.24	--	\$250.00	\$275.00
Crankshaft 2.0	039 105 101	\$2,490.94	--	\$450.00	\$275.00
8 Main Bearing Set Std.	021 198 481 A	\$142.82	\$60.70	--	--
Main Bearing Set .25	021 198 483 A	\$134.16	\$87.94	--	--
Main Bearing Set .50	021 198 485 A	\$151.87	\$75.07	--	--
9 Bolt, Hex 12x1.5x25	N0 143 361	\$2.94	\$2.75	\$2.00	--
10 Washer	021 105 275	\$6.57	\$3.50	--	--
11 Flywheel	022 105 273 A	\$665.00	\$290.20	\$125.00	\$125.00
12 Dowel Pin 6x18	N0 131 971	--	\$2.30	--	--
13 Rod Bearing Set 1.7, 1.8 Std	021 105 701 A	--	\$29.95	--	--
Rod Bearing Set 1.7, 1.8 (.25)	021 105 707 A	--	\$32.34	--	--
Rod Bearing Set 1.7, 1.8 (.50)	021 105 713 A	--	\$43.89	--	--
Rod Bearing Set 1.7, 1.8 (.75)	021 105 719 A	--	\$63.52	--	--
Rod Bearing Set 2.0 Std	039 105 701	--	\$40.42	--	--
Rod Bearing Set 2.0 (.25)	039 105 707	--	\$50.42	--	--

Description	Part Number	Gen.	Repl.	Used	Rep./Reb.
Rod Bearing Set 2.0 (.50)	039 105 713	--	\$43.89	--	--
Rod Bearing Set 2.0 (.75)	039 105 719	--	\$63.53	--	--
15 Connecting Rod 1.7, 1.8	022 105 401	\$191.18	--	\$55.00	\$82.00
Connecting Rod 2.0	039 105 401	\$181.50	--	\$100.00	\$82.00
16 Connecting Rod Nut	113 105 427	\$4.75	\$2.31	--	--
17 Connecting Rod Bushing	021 105 427	\$4.84	--	--	--
18 Woodruff Key For Crank Timing Gear	111 105 213	\$8.32	--	--	--
19 Woodruff Key 4x5 Fan Hub	N0 127 082	\$4.75	\$2.31	--	--
21 Crankshaft Timing Gear	021 105 209 A	\$98.48	--	\$75.00	--
22 Driving Gear	901 102 115 00	\$109.18	--	\$50.00	--
24 Front Main Seal	021 105 247 A	\$23.50	\$7.90	--	--
25 Piston Ring Set 1.7	021 198 175	\$160.17	\$69.24	--	--
26 Piston Ring Set 2.0	039 198 175 A	\$211.75	\$75.07	--	--
27 Piston Ring Set 1.8	021 198 175 A	\$102.56	\$79.11	--	--
28 Piston Std 1.7	021 107 111 H	\$116.16	--	\$45.00	--
Piston Std 1.8	022 107 111 H	\$127.23	--	\$45.00	--
Piston Std 2.0	039 107 111	\$193.60	--	\$75.00	--
29 Piston Pin	021 107 411 A	\$17.12	--	\$10.00	--
30 Safety Ring 24x1.2	N0 123 011	\$4.00	--	--	--
31 Oiling Washer	021 105 235	\$3.50	--	--	--
32 Distributor Drive	021 105 231	\$97.11	--	--	\$28.00
33 Distributor Drive Spring	111 105 233	\$3.36	--	--	--

Description	Part Number	Gen.	Repl.	Used	Rep./Reb.
1 Camshaft W/timing Gear	021 109 015 M (-3)	\$462.24	--	\$82.00	--
Camshaft W/timing Gear	021 109 017 M (-2)	\$376.91	--	\$82.00	--
Camshaft W/timing Gear	021 109 019 M (-1)	\$376.91	--	\$82.00	--
Camshaft W/timing Gear	021 109 021 M (0)	\$499.76	--	\$82.00	--
Camshaft W/o Timing Gear	021 109 021	--	\$173.20	--	--
Camshaft W/timing Gear	021 109 023 M (+1)	\$376.91	--	\$82.00	--
Camshaft W/timing Gear	021 109 021 K (+2)	\$376.91	--	\$82.00	--
Camshaft W/timing Gear	021 109 027 M (+3)	\$387.80	--	\$82.00	--
2 Push Rod	021 109 301 A	\$37.51	--	\$6.00	--
3 Cam Follower	021 109 309 G	\$33.04	\$16.10	\$8.00	--
4 Push Rod Tube	021 109 335 C	\$18.84	\$9.00	\$3.00	--
5 Pushrod Wire	021 109 339	--	--	\$15.00	--
6 Pushrod Tube Seal, Small	021 109 345 A	\$3.59	--	--	\$1.00*
7 Pushrod Tube Seal, Large	021 109 349	\$5.48	--	--	\$1.00*
8 Valve Adj. Lug 1.7	043 109 451	\$4.00	\$2.70	--	--
Valve Adj Lug 2.0 1973 Only	039 109 451	\$26.74	--	--	--
Valve Adj Lug 1.8, 2.0 1974-76	022 109 451	\$9.14	\$3.46	--	--
9 Valve Adj Nut 8x1 1970-73	900 078 011 00	\$3.00	\$2.30	--	--
Valve Adj Nut 10x1 1974-76	028 109 453	\$4.00	\$2.88	--	--
10 Intake Valve 1.7	021 109 601	\$41.94	\$20.70	--	--
Intake Valve 1.8	022 109 601	\$41.33	\$27.44	--	--
Intake Valve 2.0	039 109 601 G	\$91.51	\$47.90	--	--
11 Valve Cone	113 109 651 A	\$4.70	\$2.30	--	--
12 Valve Spring Plate	021 109 641 B	\$16.64	--	\$6.00	--
13 Valve Spring	021 109 623 E	\$10.40	\$9.84	--	--
14 Exhaust Valve 1.8	022 109 612	\$103.45	\$38.11	--	--
Exhaust Valve 1.7	021 109 612 A	\$85.05	\$57.70	--	--
Exhaust Valve 2.0	039 109 611 L	\$162.47	\$69.50	--	--
15 1 Set Camshaft Bearings	021 198 541	\$31.32	\$21.53	--	--
16 Thermostat	021 119 159 A	\$101.84	\$82.00	\$45.00	--
17 Thermostat Bracket	022 119 155	\$32.37	--	\$15.00	--
18 Cap Nut M7x.75	070 119 765	\$9.00	--	--	--
19 Cable For Cooling Air Control	021 119 751	\$5.57	--	--	--
20 Sealing Washer For Air Control	021 119 955	\$2.25	--	--	--
21 Throttle Flap For Cooling Air	021 119 309	\$117.82	--	\$55.00	--
22 Support For Throttle Flap Shaft	021 119 187	\$9.00	--	--	--
23 Spring For Throttle Flap Shaft	021 119 729 A	\$9.00	--	--	--
24 Throttle Flap W/Pipe	021 119 711	\$117.09	--	\$75.00	--
25 Bolt, Hex Hd M4x8	N0 102 012	\$1.00	--	--	--
26 Washer A4.3	900 025 002 02	\$1.00	--	--	--
27 Square Nut M4	021 119 725	\$4.00	--	--	--

*new Viton

Tech Tip 71: Make sure the bellows flaps are installed or your engine will run hot. It is also very important to have all sheet metal boots and gaskets in place, so no cooling air is lost.

914 Engine

ALL PRICES SUBJECT TO CHANGE WITHOUT NOTICE

Tech Tip 38: The chronic push rod tube seal problem has been solved! After careful cleaning of the tube grooves, installation of the 400-degree Viton seals and valve adjustment, the chronically leaking push rods tube seals will leak no more.

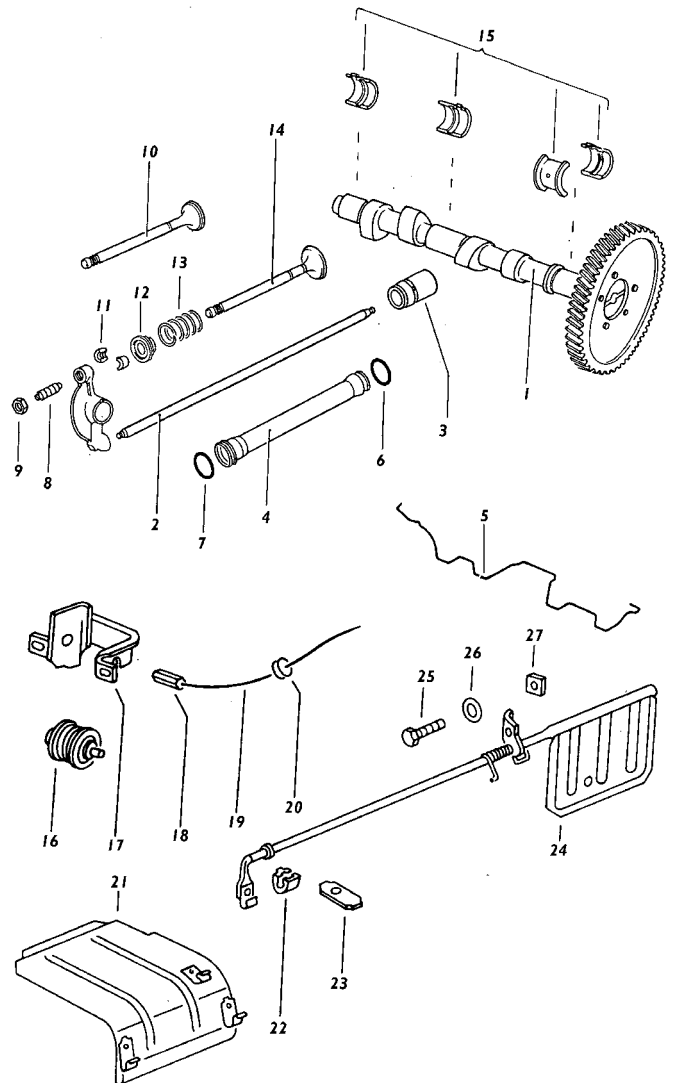

914 HARD PARTS

914 Engine

Description	Part Number	Gen.	Repl.	Used	Rep./Reb.
1 Oil Breather Complete 1.7, 2.0	022 115 451 C	\$239.83	--	\$125.00	--
2 Knurled Nut	022 115 544	\$2.00	--	--	--
3 Seal Ring	022 115 475	\$2.00	--	--	--
4 Disc Valve	022 115 542	\$15.95	--	--	--
5 Plug For Oil Breather	022 115 486	\$4.50	--	--	--
6 Clamp For Oil Breather	021 115 489	\$4.57	--	--	--
7 Cover For Oil Filler	021 115 311	\$20.37	--	--	--
8 Oil Filler Base	021 115 317 A	\$41.00	--	\$25.00	--
9 Gasket For Oil Filler	021 115 137	\$4.86	\$2.30	--	--
10 Seal Ring For Oil Filler	021 115 487	\$5.40	\$2.30	--	--
11 Cover For Oil Filler Complete 1.8	022 115 309	\$112.74	--	\$75.00	--
11A Gasket Upper	022 115 331	\$12.01	\$9.69	--	--
11B Gasket Lower	022 115 315	\$12.00	\$5.00	--	--
11C Oil Filler	022 115 317	\$113.00	--	\$58.00	--
12 Oil Level Dipstick	022 115 611	\$40.46	--	\$26.00	--
13 Oil Cooler Seal	021 117 151 A	\$4.27	\$2.88	--	--
14 Oil Cooler	021 117 021 B	\$241.52	\$155.92	\$75.00	--
15 Support For Oil Cooler	021 117 181	\$29.76	--	\$15.00	--
16 Oil Dipstick Tube	113 115 631	\$26.62	--	--	--

Tech Tip 58: If your 1.8 does not idle, try replacing the two oil cap seals.

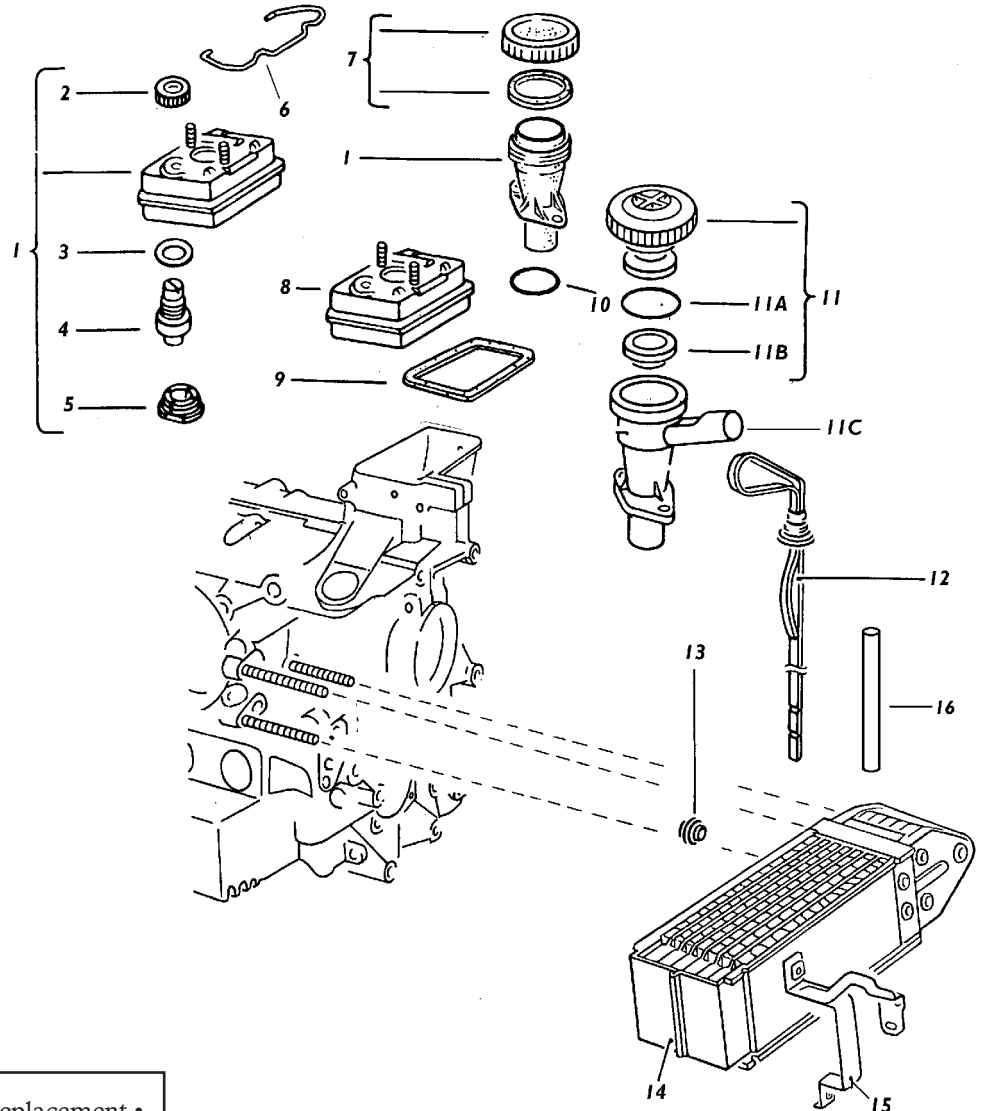

Tech Tip 55: The oil dipstick tube length is critical for proper oil level measure. It is 161 mm long and protrudes from the case 150 mm. The tube is available for replacement.

Tech tip 58: 914 oil coolers almost never leak, but the oil cooler seals do leak. They can be replaced with the engine in the car.

G = Genuine • R = Aftermarket / Replacement •
U = Used • B = Rebuilt or Reproduction

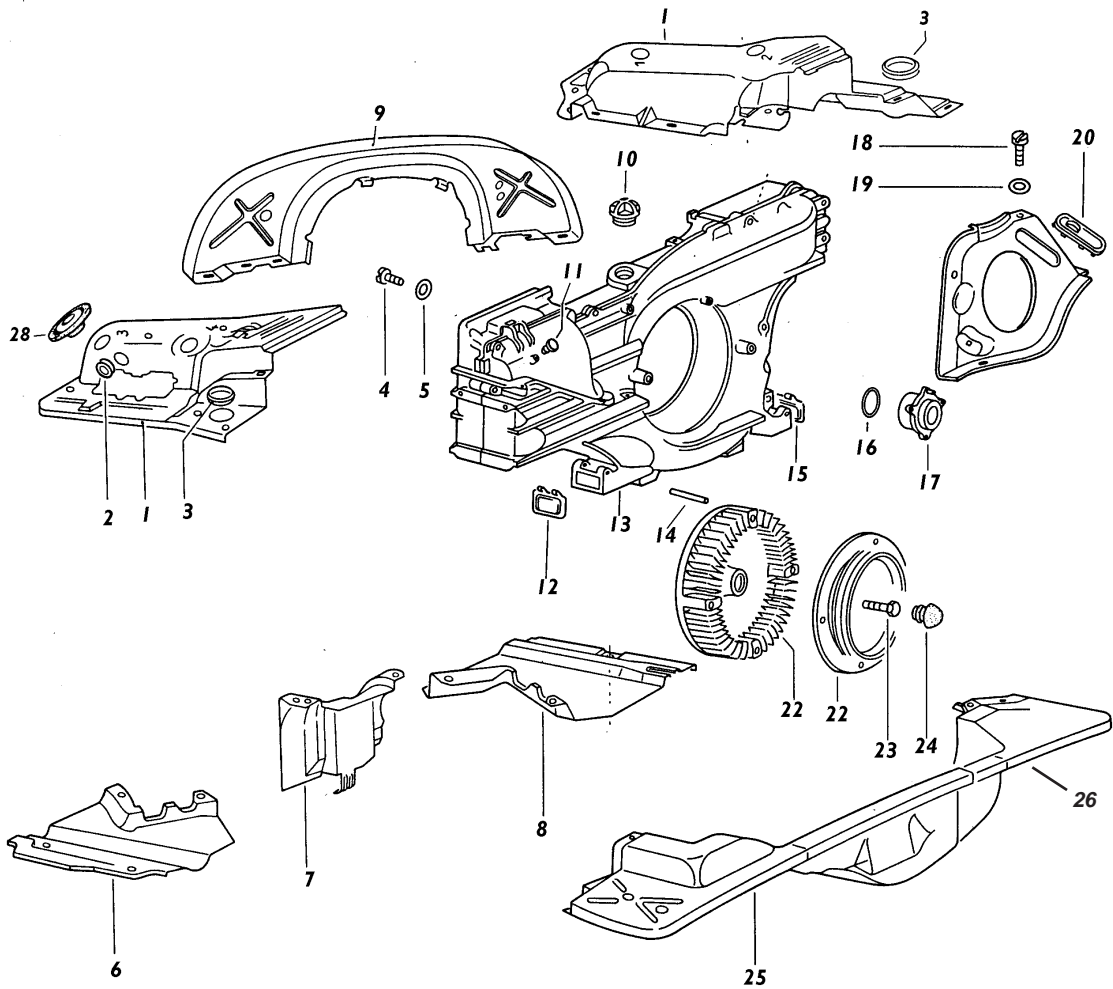

**DON'T SEE EXACTLY
WHAT YOU NEED?
CALL US!**

Description	Part Number	Gen.	Repl.	Used	Rep./Reb.
1 Cylinder Cover 1.7/1.8 Right	022.119.299.A	\$291.65	--	\$150.00	--
Cylinder Cover 1.7/1.8 Left	022.119.300.D	\$291.65	--	\$150.00	--
Cylinder Cover 2.0 Right	039.119.299.A	\$367.95	--	\$195.00	--
Cylinder Cover 2.0 Left	039.119.300.C	\$341.22	--	\$185.00	--
2 Grommet For Headtemp Sensor	021.119.337	\$12.18	--	--	--
3 J Pipe Grommet	021.119.569	\$19.07	--	--	--
4 Screw, Cheese Head Am 6x15	N0.107.152	\$1.00	\$1.00	--	--
5 Washer 7	N0.116.521	\$1.00	\$1.00	--	--
6 Air Guide Plate, 2.0 Right 1975-76	039.119.354	\$75.79	--	\$28.00	\$45.00
Air Guide Plate, Right 1970-72	022.119.356	\$70.18	--	\$28.00	--
Air Guide Plate, 1.7/1.8 Left 1973-74	022.119.356.A	\$71.29	--	\$28.00	\$45.00
7 Deflector Plate	021.119.358	\$43.79	--	\$28.00	--
8 Air Guide Plate, 2.0, Left 1975-76	039.119.353	\$63.80	--	\$28.00	\$63.00
Air Guide Plate, 1.7/1.8 Right 1970-74	022.119.355	\$71.98	--	\$28.00	--
9 Rear Engine Cover	022.119.517.R	\$83.20	--	\$30.00	--
10 Timing Hole Plug	021.119.233.A	\$32.00	--	\$14.00	--

Description	Part Number	Gen.	Repl.	Used	Rep./Reb.
12 Impellor Flap R	021.119.263.A	\$27.71	--	\$15.00	--
13 Fan Housing Usa	021.119.199.N	\$545.87	--	\$150.00	--
14 Impellor Flap Pin	021.119.270	--	--	--	\$1.00
15 Impellor Flap, L	021.119.264.A	\$24.87	--	\$15.00	--
16 Impellor Hub Seal	021.119.125.A	\$4.35	--	--	--
17 Hub For Fan	021.119.119	\$219.41	--	\$115.00	--
18 Cheese Head Screw Am 6x12	N0.141.395	\$1.13	\$1.10	--	--
19 Washer 7	N0.116.521	\$1.00	\$1.00	--	--
20 Cover For Coverplate	021.119.295.10	\$20.50	\$9.50	--	\$15.00
21 Air Cover Plate	021.119.281.D	\$323.55	--	\$175.00	--
22 Fan	021.119.031.Ad	\$360.89	--	\$175.00	--
23 Bolt, Hex Hd Self Locking M8x30	N0.143.261	\$3.50	\$2.30	--	--
24 Cap For Fan	021.119.149	\$22.37	--	\$15.00	--
25 Front Engine Cover, Right	022.119.521.A	\$161.40	--	\$95.00	--
26 Front Engine Cover, Left	022.119.512	\$177.82	--	\$75.00	--
28 Spark Plug Boot	111.905.449.A	\$5.02	\$3.47	--	--

914 HARD PARTS

914 Fuel Injection System

Tech Tip 88: A leaking cold start valve, often an overlooked item, can cause hard starting when hot and a rich idle. Eliminating it from the system and monitoring its operation will tell all.

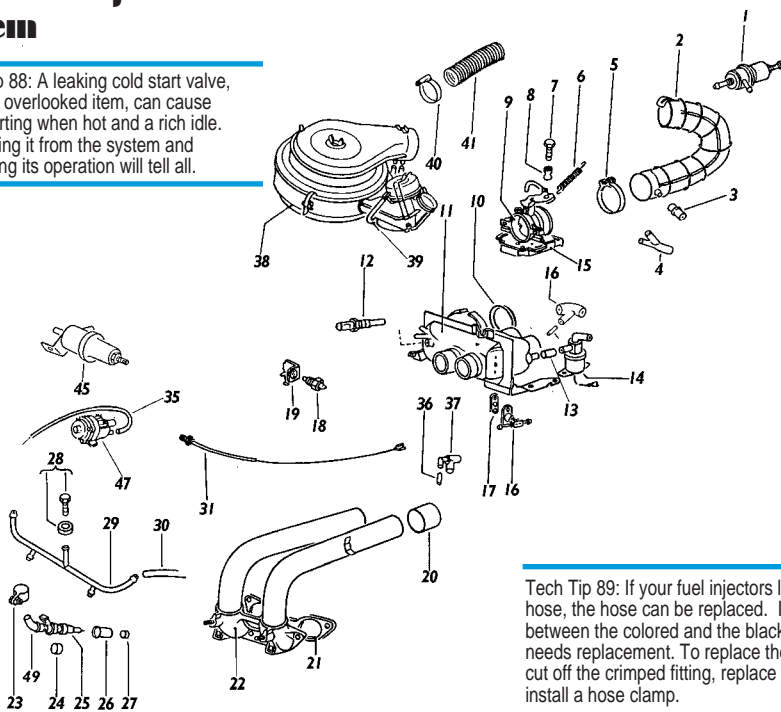

Tech Tip 89: If your fuel injectors leak at the hose, the hose can be replaced. If they leak between the colored and the black, the injector needs replacement. To replace the hose, simply cut off the crimped fitting, replace the hose, and install a hose clamp.

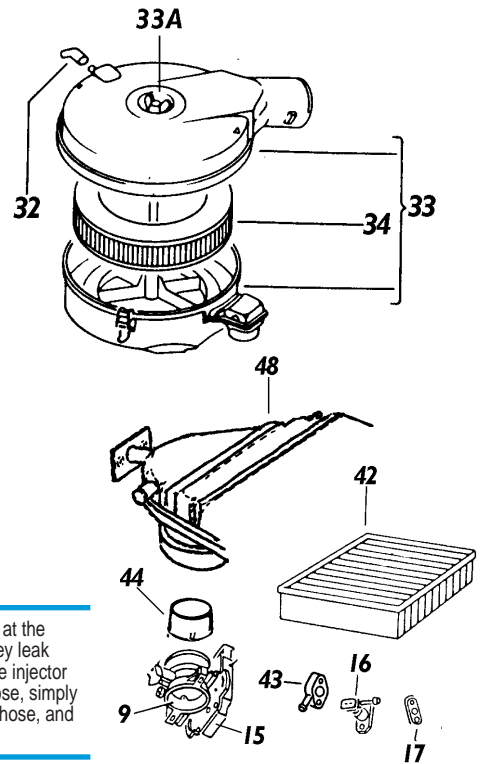

Description	Part Number	Gen.	Repl.	Used	Rep./Reb.
1 Pressure Regulator 1.7/2.0	311 133 030 A	\$168.71	--	\$35.00	--
Pressure Regulator 1.8	022 906 035	\$175.81	\$86.62	\$45.00	--
Elbow For Air Filter	022 129 967 P	\$175.81	--	\$75.00	\$85.00
3 Connecting Hose For Pipe	022 133 199	\$21.00	--	\$10.50	--
Connecting Hose For Pipe	022 133 199 A	\$23.24	--	\$10.00	--
4 Y-Piece	022 133 215	\$21.00	--	\$1.00	--
5 Hose Clip 62-87mm	211 255 463	\$11.05	\$2.66	--	--
6 Return Spring For Acc. Cable 102mm 2.0	039 129 881 A	\$10.98	\$5.77	--	--
Return Spring For Acc. Cable 100mm 1.7/1.8	022 129 881 F	\$8.35	\$6.90	--	--
7 Barrel Bolt	NO 102 056	\$1.00	\$1.15	--	--
8 Barrel Bolt	111 129 921	\$9.49	\$4.80	--	--
9 Throttle Valve Socket 1.7	022 133 062 D	\$306.95	--	\$135.00	--
Throttle Valve Socket 2.0	039 133 062 D	\$351.44	--	\$225.00	--
10 Gasket For Throttle Valve Socket 1.7	022 133 073	\$11.94	--	--	--
Gasket For Throttle Valve Socket 1.8	022 133 073 A	\$13.46	--	--	--
Gasket For Throttle Valve Socket 2.0	039 133 073	\$14.31	--	--	--
11 Intake Air Distributor 1.7	022 133 055 G	\$153.01	--	\$40.00	--
Intake Air Distributor 2.0	039 133 055 B	\$453.76	--	\$175.00	--
12 Intake Air Temp Switch	311 906 081 A	\$54.84	\$35.47	\$15.00	--
13 Hose 12x3.3	NO 202 901	\$27.38	\$6.00/ft.	--	--
14 Aux. Air Regulator 1.7/2.0	022 906 045	--	--	\$175.00	\$159.00
Aux. Air Regulator 1.8	022 906 045 A	\$244.12	\$190.57	\$77.00	\$104.00
15 Throttle Valve Switch, Early, 1.7	022 906 111 A	\$271.70	\$190.00	\$75.00	--
Throttle Valve Switch, Late, 1.7	022 906 111 B	\$171.70	\$145.00	\$75.00	--
Throttle Valve Switch, 1.8	022 906 111 D	\$144.96	\$77.56	\$45.00	--
Throttle Valve Switch 2.0	039 906 111	\$354.00	--	\$150.00	--
16 Cold Start Valve, 1.7	022 906 171 A	\$145.31	--	\$75.00	--
Cold Start Valve, 1.8	022 906 171 B	\$187.09	--	\$75.00	--
Cold Start Valve, 2.0	311 906 171 B	\$291.91	--	\$126.00	--
17 Cold Start Valve Gasket 1.7	022 133 075	\$2.42	--	--	--
Cold Start Valve Gasket 1.8	022 133 075 A	\$4.06	--	--	--
Cold Start Valve Gasket 2.0 (.5mm)	039 133 075 A	\$9.00	--	--	--
Cold Start Valve Gasket 2.0 (.8mm)	039 133 075 B	\$11.08	--	--	--
18 Thermo Switch 1970-73 1.7	311 906 161 A	\$125.75	--	\$75.00	--
Thermo Switch 1973-74 2.0	311 906 161 C	\$134.16	--	\$75.00	--
Thermo Switch 1974 1.8	022 906 163	\$125.55	--	\$75.00	--
Thermo Switch 1975 1.8	022 906 163 A	\$160.37	--	\$75.00	--
Thermo Switch 1975-76 2.0	043 906 163	\$116.27	\$79.60	--	--
19 Thermo Switch Bracket 1.7	022 133 285 A	\$18.49	--	\$10.00	--
Thermo Switch Bracket 1.8	022 133 285 B	\$18.49	--	\$10.00	--
Thermo Switch Bracket 2.0	039 133 285 B	\$18.22	--	\$10.00	--
20 Intake Runner Boot, 1.7	022 133 241 B	\$17.33	\$7.50	--	--
Intake Runner Boot, 1.8/2.0	039 133 241	\$13.67	\$7.50	--	--

Description	Part Number	Gen.	Repl.	Used	Rep./Reb.
21 Gasket For Intake Pipe 1.7	022 129 707 C	\$14.14	\$11.55	--	--
Gasket For Intake Pipe 1.8	022 129 707 F	\$14.14	\$11.55	--	--
Gasket For Intake Pipe 2.0	039 129 707	\$24.93	\$13.00	--	--
22 Intake Pipe, Right 1.7	022 133 201 B	\$138.04	--	\$50.00	--
Intake Pipe, Right 1.8	022 133 201 D	\$146.09	--	\$75.00	--
Intake Pipe, Left 1.7	022 133 202 B	\$135.93	--	\$50.00	--
Intake Pipe, Left 1.8	022 133 202 D	\$146.09	--	\$75.00	--
Intake Pipe 2.0	039 133 201 B	\$380.32	--	\$110.00	--
23 Clip For Fuel Hose 13mm	999 512 255 02	\$1.93	\$1.73	--	--
24 Fuel Injector Seal, Large	311 133 263	\$3.58	\$1.15	--	--
25 Fuel Injector 1.7	022 906 031 A	\$398.10	\$202.00	--	\$47.00*
Fuel Injector 1.8	022 906 031 C	\$270.79	\$118.38	--	\$46.70*
Fuel Injector 2.0 1973-74	039 906 031	\$289.42	\$155.00	--	\$65.00*
Fuel Injector 2.0 1975-76	039 906 031 A	\$289.52	\$190.09	--	\$75.00*
26 Protective Sleeve For Fuel Inj. 1.7	311 906 033	\$4.00	\$2.15	--	--
27 Fuel Injector Seal, Small	311 133 261 A	\$2.86	\$1.15	--	--
28 Bolt, Hex Hd W/seal Ring M4x8	NO 901 961	\$11.00	\$2.30	--	--
29 Fuel Distributor	022 133 315 A	\$127.65	--	\$25.00	--
30 Fuel Line High Press Per Foot	N 202 811	\$16.94	\$5.77	--	--
31 Head Temperature Sensor, Early 74	311 906 041 A	\$41.16	\$30.20	--	--
Head Temperature Sensor, Late 75-76	022 906 041 A	\$52.82	\$32.94	--	--
32 Elbow For Connecting Hose	022 129 637	\$6.58	\$5.19	--	--
33 Air Cleaner 1.7, 1973	022 129 607 H	\$273.22	--	\$250.00	--
33a Wingnut For Air Cleaner	900 029 003 02	--	--	--	\$15.00
34 Filter Cartridge For Air Filter 73 1.7	022 129 620	\$51.34	\$14.43	--	--
35 Vacuum Line 9mm, Per Foot	NO 202 811	\$32.34	--	--	--
36 Pipe	022 133 085	--	--	\$4.50	--
37 Stacked Vacuum Elbow	022 129 637 B	\$35.65	--	\$20.00	--
38 Air Cleaner Oil Bath 70-72 1.7	022 129 607	\$244.03	--	\$75.00	--
39 Vacuum Line 4.5 mm, Per Foot	NO 203 612	\$26.71	\$3.46	--	--
40 Heater Hose Clamp	111 501 159 B	\$6.07	\$3.30	--	--
41 Connecting Hose For Intake Air Pre-Heat	411 819 365 A	\$15.42	\$9.20	--	--
42 Filter Cartridge For Air Filter 1.8, 2.0	039 129 620 A	\$18.47	\$11.50	--	--
43 Intermediate For Cold Start Valve	039 133 079 A	\$15.42	--	\$10.00	--
44 Throttle Valve Socket 2.0	033 133 062	\$217.54	--	\$15.00	--
45 Decel Valve (USA) 1.7/1.8	022 133 551	\$164.87	--	\$100.00	--
Decel Valve (Pneumatic) 2.0	039 133 551	\$175.00	--	\$100.00	--
46 Branch Vacuum Elbow	022 133 083	\$9.93	--	--	--
47 Pressure Sensor 1.7	022 906 051 E	\$1,411.18	\$770.00	--	\$275.00
Pressure Sensor 2.0	039 906 051	\$1,370.97	--	--	\$275.00
48 Air Cleaner 2.0	039 129 607 A	\$1,278.23	--	\$250.00	--
49 Fuel Injector Hose	043 133 387	\$15.00	--	\$9.50	--

* Rebuild Parts Require A Rebuildable Core

914 Fuel Injection System

Description	Part Number	Gen.	Repl.	Used	Rep./Reb.
1 Air Filter Cartridge 1.8/2.0	039 129 620 A	\$18.47	\$12.00	--	--
2 Air Filter 1.8	022 129 607 K	\$276.16	--	\$150.00	--
Air Filter 2.0	039 129 607 H	\$364.18	--	\$150.00	--
3 Air Flow Sensor Gasket	022 129 683	\$5.46	--	--	--
4 Air Flow Sensor, 1.8 1974	022 906 301	\$1,226.65	\$401.00	--	\$181.00*
Air Flow Sensor, 1.8 1975	473 906 301	\$1,795.91	\$489.00	--	\$181.00*
5 Fitting	022 133 199C	\$15.00	--	\$10.00	--
6 Elbow	022 129 967 AA	\$78.78	--	\$49.50	--
7 Hose For Aux. Air Regulator Per Foot	N 020 377.1	\$30.40	\$9.00	--	--
8 Throttle Valve Switch 1.8	022 906 111 D	\$144.96	\$77.56	\$45.00	--
9 Valve, 1.8 Decel	022 133 551 B	--	--	\$145.00	--
10 T Piece	113 201 943 B	\$10.00	--	--	\$6.00
11 Hose 4x2.5 Per Foot	N0 203 612	\$26.71	\$3.46	--	--
12 Drive Shaft W/Pulley	021 131 681	\$657.90	--	\$450.00	--
13 Air Pump For Secondary Air Inj. Sys.	039 131 601	\$493.42	--	\$250.00	\$165.00
14 Return Valve	058 131 603	\$136.50	--	--	--
15 Socket	021 131 285	\$133.20	--	\$50.00	--
16 Air Diffuser	039 131 581 A	\$360.55	--	\$250.00	--
17 Filter Cartridge	113 131 123	\$31.18	\$19.31	--	--
18 Air Cleaner For Air Pump	021 131 801	\$154.63	--	\$45.00	--
19 Tube (California)	039 131 673	\$111.50	--	\$75.00	--
20 Gasket	021 131 599 A	\$1.78	--	--	--
21 Gasket	021 131 599	\$1.98	--	--	--
22 Valve (California)	039 131 501	\$264.27	--	\$150.00	--
23 Gasket	071 131 599 C	\$2.14	--	--	--
24 Tube (California)	039 131 635	\$184.10	--	\$150.00	--
25 Tube (California)	039 131 631	\$198.90	--	\$100.00	--
26 Pressure Regulator	022 906 035	\$175.70	\$86.62	\$45.00	--
27 V-belt	039 131 615	\$22.00	\$7.50	--	--
28 Aux Air Regulator 1.8	022 906 045 A	\$244.12	\$190.57	\$77.00	\$104.00*
29 Intake Air Distributor 1.8	022 133 055 G	\$153.00	--	\$40.00	--
30 Throttle Valve Socket 1.8	022 133 062 H	\$480.72	--	\$175.00	--

* Rebuilt Parts Require A Rebuildable Core

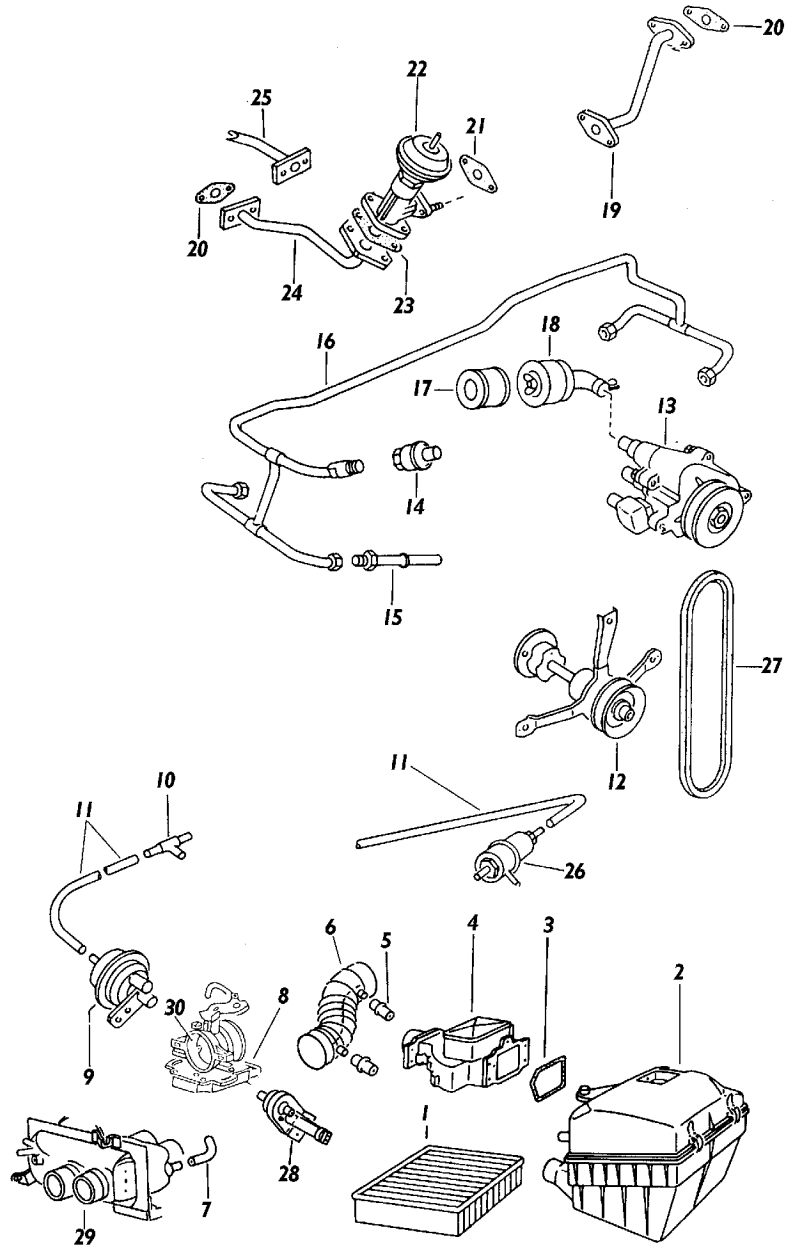

Tech Tip 75: If your 1.8 runs rich at idle and floods out, your air flow meter flap is sticking, and the meter needs replacement. Lean backfire usually causes this problem. Check all engine vacuum hoses for tightness and make sure that at hot idle you have at least 15 inches of engine vacuum.

Tech Tip 113: If you notice an engine compartment exhaust leak on your 75-76 914 2.0, the air injection nozzle has loosened from the head.

Tech Tip 114: If you notice a front engine rattle on your 75-76 914 2.0 as the air pump pulley spins, the drive pulley dampener on the engine fan has probably broken.

Parts that are replacement, used or reproduction are not approved, guaranteed, or warranted by Porsche; use of unapproved parts may negate the factory warranty, or alter safety, emission, aerodynamics, or fuel consumption characteristics.

914 HARD PARTS

Description	Part Number	Gen.	Repl.	Used	Rep./Reb.
1 Bolt, Hex Hd M8x15	900 075 104 01	\$1.00	\$1.00	--	--
2 Spring Ring BB	900 027 015 01	\$1.00	\$1.00	--	--
3 Pressure Plate	901 116 011 01	\$211.75	\$159.30	--	\$82.00*
4 Clutch Disc	914 116 011 04	\$358.66	\$155.92	--	\$82.00*
5a Pre Exhaust Silencer 1.8/2.0	039 251 053	\$792.30	--	--	--
5b Secondary Silencer 1.8/2.0	039 251 055 A	\$675.95	\$431.00	--	--
5c Exhaust Gas Pipe (Center) 1.8/2.0	039 251 058	\$69.30	\$40.90	--	--
6 Gasket	443 253 115 B	\$18.36	\$5.19	--	--
7 Catalytic Converter (California)	055 131 701	\$849.89	\$195.77	--	--
8 Nut, Hex M8 Self Locking	311 101 463	\$4.20	\$2.20	--	--
9 Washer 8.4	N0 116 701	\$1.67	\$1.00	--	--
10 Bolt, Hex Hd M8x35	N0 102 478	\$1.09	\$1.00	--	--
11 Bolt, Hex Hd M8x28	N0 102 336	\$3.12	\$1.10	--	--
12 Chrome Muffler Tip 1.8, 1.7	ZPW 151 052	--	\$40.42	--	--
13 Muffler 2.0 1973-74	039 251 053	\$792.30	\$695.00	--	--
14 Bracket For Exhaust Muffler	022 251 067 A	\$129.03	--	--	\$40.00
15 Bracket For Exhaust Muffler 2.0	039 251 067	\$137.97	--	\$25.00	\$43.40*
16 Seal For Tailpipe W/damper	021 251 231 B	\$4.61	\$3.46	--	--
17 Taper Ring For Tailpipe W/Damper	021 251 233 A	\$2.00	\$1.15	--	--
18 Spring Ring BB	900 027 015 02	\$1.00	\$1.00	--	--
19 Bolt, Hex Hd M8x22	900 075 079 02	\$1.00	\$1.00	--	--
20 Tailpipe For Muffler 1970-71 021 251 101 E	021 251 171 M	\$149.65	\$57.70	--	--
Tailpipe For Muffler 1973 1.7 021 251 101 K	021 251 171 N	\$130.35	--	--	\$55.00*
Tailpipe For Muffler 1974 1.8 021 251 053 C	021 251 185 C	\$69.50	\$33.49	--	--
21 Muffler 1.7/1.8 021 251 101 E	021 251 053 C	\$640.84	\$375.00	--	\$55.00*
22 Stud Bm 8bx31	N0 144 632	\$5.00	\$3.46	--	--
23 Muffler Gasket 1.7/1.8	025 251 261	\$12.85	\$5.48	--	--
Muffler Gasket 2.0	039 251 261	\$9.65	\$5.19	--	--
24 Muffler Bracket 1975-76	039 251 067 A	\$67.50	--	\$45.00	--

* Rebuilt Parts Require A Rebuildable Core

Tech Tip 116: If your clutch is slipping (revving too high compared to speed, especially under a load or going up hills), and you have some clutch pedal free play, the clutch is worn out and needs replacement.

Tech Tip 121: Relining the clutch disc is both practical and economical, as well as factory recommended. So don't hesitate to purchase a rebuilt clutch disc!

Tech Tip 125: Always check your heat exchangers when ordering a muffler. Since all four cylinder heat exchangers/muffler systems fit all 914s, you may not have the same exhaust system originally fitted to your 914.

914 Exhaust System

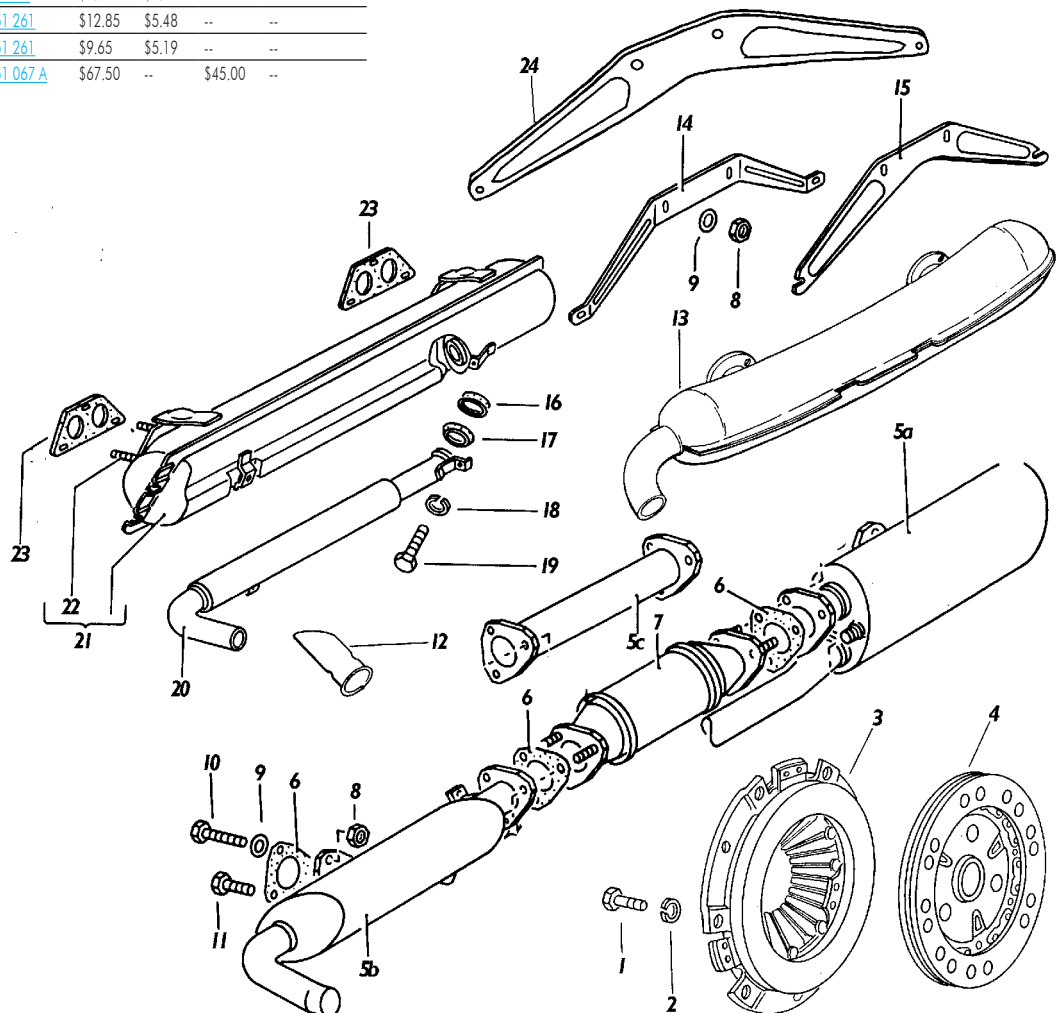

Description	Part Number	Gen.	Repl.	Used	Rep./Reb.
1 Hot Air Blower Bracket	473 261 207	\$85.00	--	\$25.00	--
2 Hot Air Hose 55mm	461 261 235 A	\$35.00	--	\$13.20	--
3 Heater Hose Clamps	111 501 159 B	\$6.07	\$3.30	--	--
4 Air Flow Tube, Left Short 70-72	473 261 233	\$35.00	--	\$8.80	--
5 Hot Air Blower 70-72	473 261 193	\$458.58	--	\$250.00	--
6 Heating Hose 280mm	914 572 154 10	\$46.61	--	\$13.70	--
7 J Pipe, Left	PCG 256 331 GRV	\$76.84	--	\$45.00	--
8 Heat Control Valve, Right	022 256 206 A	\$251.14	\$120.00	\$105.00	--
Heat Control Valve, Left	022 256 205 A	\$217.04	\$120.00	--	--
9 Warm Air Elbow	022 256 121	\$81.81	--	\$38.00	\$30.80
10 Washer 6mm	NO 116 521	\$1.00	\$1.00	--	--
11 Spring Washer B6	NO 122 262	\$1.00	\$1.00	--	--
12 Bolt, Hex Hd M6x10k	NO 102 107	\$1.00	\$1.00	--	--
13 Exhaust Copper O-ring, 1.7	021 256 251 A	\$3.64	\$2.30	--	--
Exhaust Copper O-ring, 1.8/2.0	039 256 251	\$3.52	\$2.30	--	--
14 Heat Exchanger, Left 1.7/1.8	022 256 091 F	\$694.27	--	\$150.00	--
Heat Exchanger, Left 2.0	039 256 091	\$935.86	--	\$250.00	--
15 Hexagon Nut M8	311 101 463	\$4.20	\$2.20	--	--
16 Heat Exchanger, Right 1.7/1.8	022 256 092 F	\$671.72	--	--	--
Heat Exchanger, Right 2.0	039 256 092	\$935.86	--	\$200.00	--
19 Branch Piece, Left	022 256 501 A	\$168.64	--	\$105.00	--
20 Branch Piece To Impeller Clamp, Left	021 256 322 B	\$14.45	--	\$8.50	--
21 Branch Piece To Impeller Clamp, Right	021 256 321 D	\$14.45	--	\$8.00	--
22 Branch Piece, Right	022 256 502 A	\$168.64	--	\$105.00	--
23 Heating Hose, Right 215mm	914 572 154 10	\$46.61	\$14.50	--	\$14.50
24 J Pipe, Right	PCG 256 332 GRV	\$76.22	--	\$45.00	--
25 Rear Branch Piece Clamp	022 256 511	\$18.58	--	\$4.00	\$10.00
26 J Pipe, Left 1975-76	039 256 331	\$135.24	--	\$40.00	--
J Pipe, Right 1975-76	039 256 332	\$143.89	--	\$40.00	--
27 Exhaust Flange Gasket	043 251 509	\$18.36	\$5.19	--	--
28 Exhaust Gas Pipe, Left	039 256 281 A	\$433.46	--	\$175.00	--
Exhaust Gas Pipe, Right	039 256 282 A	\$388.78	--	\$175.00	--
29 Heat Exchanger, Left 1.8/2.0 1975-76	039 256 091 A	\$935.86	--	\$650.00	--
Heat Exchanger, Right 1.8/2.0 1975-76	039 256 092 A	\$935.86	--	\$475.00	--
30 Branch Clamp Gasket	021 256 326 A	\$30.61	--	--	--
31 Branch Clamp Gasket	021 256 325 A	\$27.74	--	--	--
32 J Pipe Cap	411 261 813	--	--	\$25.00	--
33 Heat Exchanger Nut	039 256 297	\$16.10	\$2.30	--	--

Tech Tip 137: Warm air elbows were installed between the heat exchanger and the control valve on 70-74 914-4 models. "J" pipes were installed between the branch piece and the cylinder cover on all models, and plastic blower hoses connected to them. 75-76 models had installed a one-piece heat exchanger with a built-in branch piece and the heater control valves connected to the heat exchangers.

A problem existed in these heat exchangers: the sheet metal branch piece rusted away and fell off, while the remaining heat exchanger looked perfectly useable. This rusted away branch piece, however, rendered the heat exchanger useless.

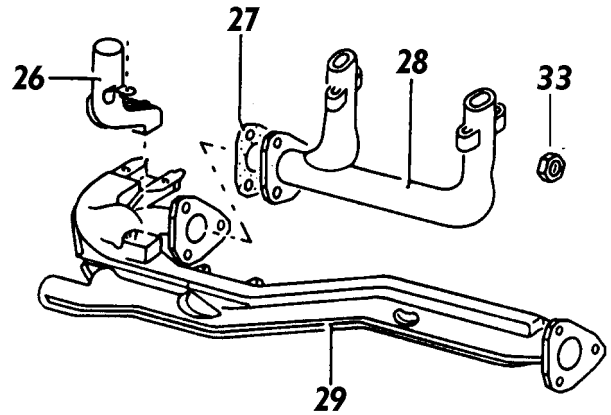

Tech Tip 135: Use only high quality aircraft-type hoses between the control valve and the body. Besides lasting longer, these hoses will take the flex of powertrain movement without breaking.

Tech Tip 125: Always check your heat exchangers when ordering a muffler. Since all four cylinder heat exchangers/muffler systems fit all 914s, you may not have the same exhaust system originally fitted to your 914.

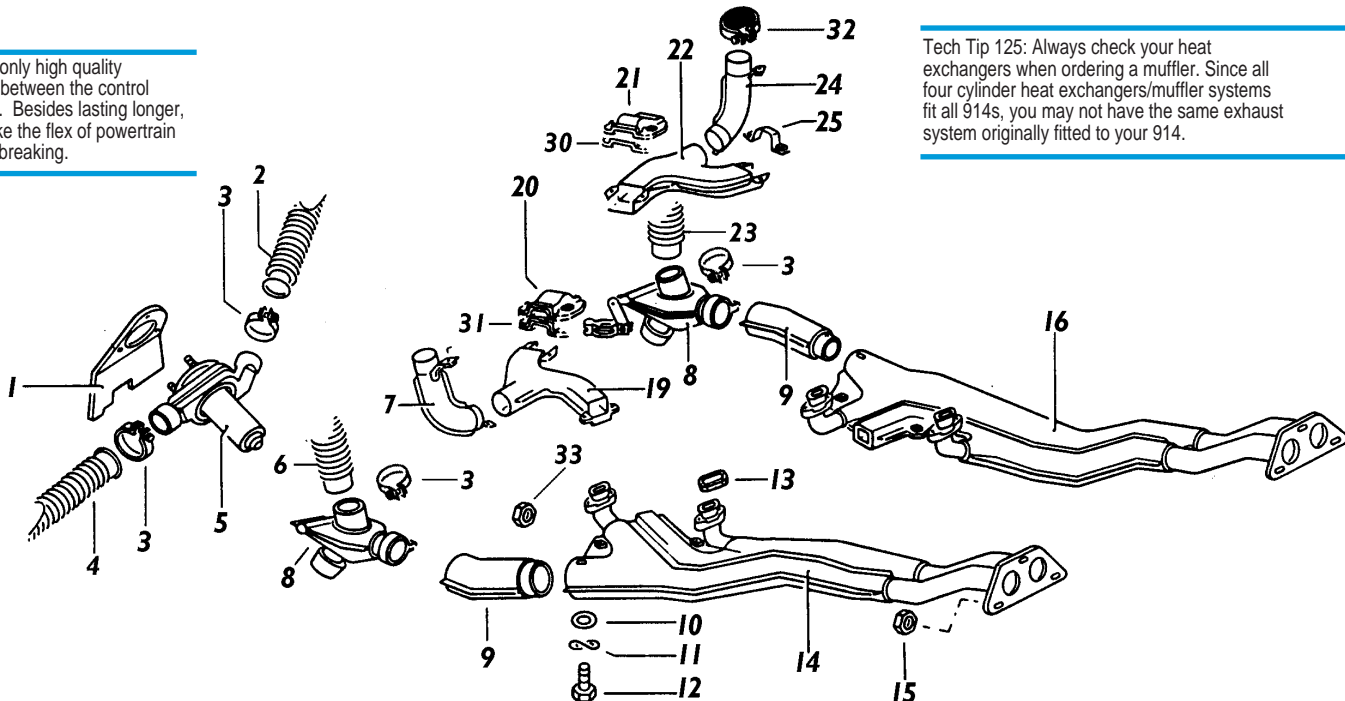

914 HARD PARTS

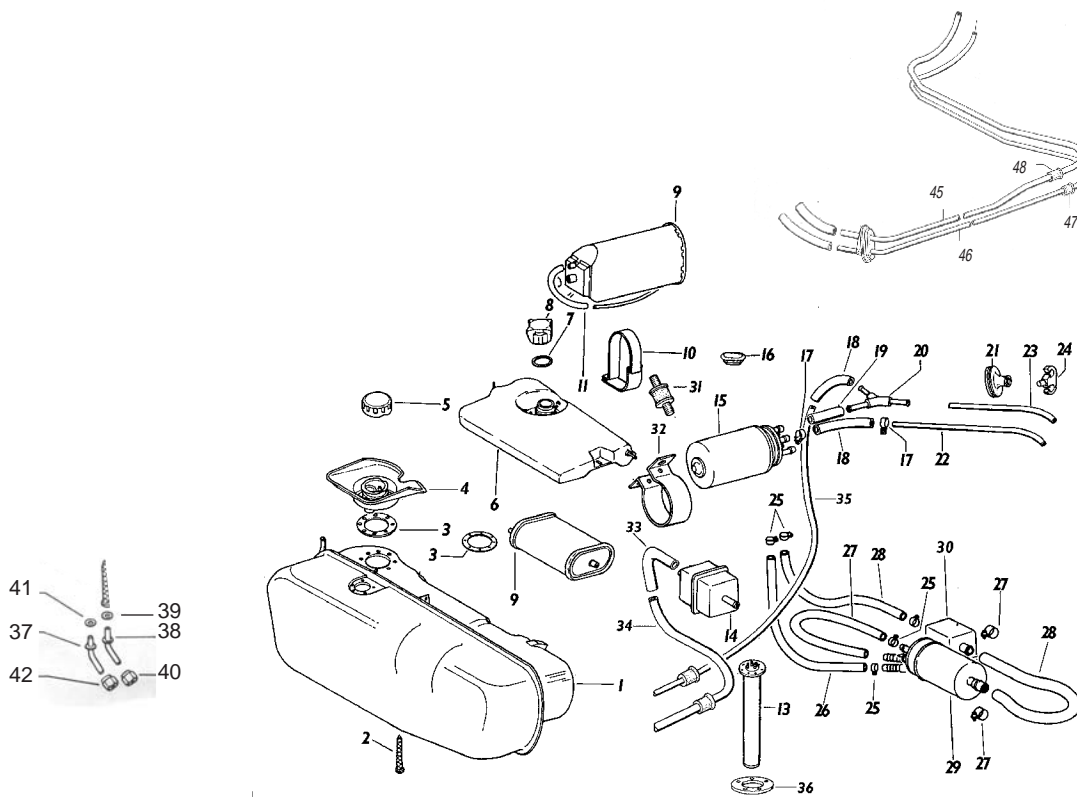

Tech Tip 146: If your 70-74 914 refuses to start after a quick trip into the convenience store on a hot day, it is probably vapor-locking. This is caused by hot air from the engine/right heat exchanger radiating on the fuel pump and boiling the fuel. This solution is to relocate the fuel pump to the front as the factory did on the 75-76 models. Fuel pump relocation kits are available aftermarket and solve the vapor lock problem.

Tech Tip 154: All 70-74 914-4 models use a reducing hose (9 mm to 7 mm) between the main plastic fuel delivery line in the tunnel and the fuel filter. The part number is 914 356 525 00. If this reducing line is not used, a serious leak and possible fire can occur where the larger 9mm fuel line attaches to the 7mm fuel filter fitting.

914 & 914-6 Fuel System

Description	Part Number	Gen.	Repl.	Used	Rep./Reb.
1 Fuel Tank 1970-73	914 201 010 10	\$1,218.56	--	\$650.00	--
Fuel Tank 1974-76	914 201 010 12	\$1,325.18	--	\$650.00	--
2 Strainer Screen 1970-74	111 209 147 A	\$16.49	\$8.44	--	--
Strainer Screen 1975-76	113 209 147	\$15.70	\$7.42	--	--
3 Gas Tank Seal	914 201 893 10	\$10.82	--	--	--
4 Filler	914 201 019 10	\$221.58	--	\$78.00	--
5 Gas Cap	343 201 551	\$49.15	--	\$28.00	\$19.50
6 Extension Container 1973 Chassis 473 292 4903	914 201 083 10	\$124.04	--	\$25.00	--
Extension Container (California) 1975-76	914 201 083 11	\$113.68	--	\$35.00	--
7 Gas Cap Seal	914 201 227 10	\$4.64	--	--	--
8 Gas Cap 74.5-76	914 201 207 10	\$15.35	--	\$11.50	--
9 Carbon Filter	1H0 201 801 C	\$95.34	--	\$40.00	--
10 Tightening Strap 1975-76	914 201 095 10	\$17.17	--	\$10.00	--
11 Vacuum Line (280mm) 12mm	N0 203 612	\$26.71	\$3.46	--	--
13 Fuel Tank Sender	901 741 801 00	\$214.52	\$110.00	\$50.00	--
14 Fuel Filter 1970-74	113 133 511	\$36.90	\$17.60	--	--
15 Electrical Fuel Pump	311 906 091 D	\$648.56	\$428.20	\$145.00	\$187.00*
16 Engine Shelf Plug 914-6	914 559 245 10	\$21.00	--	--	--
17 Hose Clip S12/9zy	999 512 055 02	\$2.37	\$1.73	--	--
18 Fuel Hose C7x12 (65mm) 1970-73	999 180 030 50	\$22.33	\$3.46	--	--
19 Fuel Hose (Return) C7x12 (40mm) 1970-71	999 180 030 50	\$22.33	\$3.46	--	--
20 Hose Connecting Piece End Of 1973 Branch Piece From 1974	901 356 451 000	\$35.70	--	\$15.00	--
	022 133 525 A	\$33.19	--	\$15.00	--
21 Fuel Line Grommet	111 957 861	\$6.50	--	--	--
22 Fuel Line (Pressure Line) 1970-76	914 356 526 00	\$40.64	--	--	\$35.00

Description	Part Number	Gen.	Repl.	Used	Rep./Reb.
23 Fuel Line (Return) 1970-71	914 356 528 00	\$43.40	--	--	\$35.00 (1)
Fuel Line (Return) 1972-76	914 356 528 01	\$43.40	--	--	\$35.00
24 Clamp 1974-76	914 356 502 01	\$9.60	--	--	--
25 Hose Clamp 7mm	N0 241 191	\$3.50	\$1.73	--	--
26 Fuel Hose C7x12 (440mm) Perfect	999 180 030 50	\$22.33	\$3.46	--	--
27 Hose Clamp Large 12mm	N0 242 41	\$3.50	\$1.73	--	--
28 Fuel Hose C11x17.5 (470mm) Perfect	999 180 029 50	\$25.51	\$3.46	--	--
29 Fuel Pump	043 906 091	\$300.12	\$225.22	--	\$159.00
30 Fuel Filter 1975-76	133 133 511	\$32.96	\$13.00	--	--
31 Fuel Pump Mount	901 501 864 00	\$33.85	\$7.20	--	--
32 Fuel Pump Clamp	914 356 503 00	\$15.70	--	--	--
33 Reducing Hose To Fuel Filter 8 to 7mm	914 356 525 00	\$32.08	\$30.00	--	--
34 Deliver Line Through Tunnel	914 356 062 01	\$98.89	--	--	\$75.00
35 Return Line Through Tunnel	914 356 063 00	\$93.70	--	--	\$75.00
36 Fuel Sender Gasket	113 919 133	\$16.33	\$7.10	--	--
37 Nipple Return Line	914 201 041 10	\$60.23	--	\$35.00	--
38 Nipple Feed Line	914 201 043 10	\$49.14	--	\$35.00	--
39 Washer	914 201 147 10	\$1.00	--	--	--
40 Nut for Nipple	914 201 153 10	\$15.16	--	--	--
41 Washer	311 201 235 A	\$1.00	--	--	--
42 Nut for Nipple	311 201 231 A	\$15.16	--	--	--
43 Drain Bushing	914 356 202 00	\$8.50	--	--	--
44 Rubber Sleeve	914 356 201 00	\$8.50	--	--	--
45 Fuel Delivery Line	914 356 524 02	\$65.78	--	--	--
46 Fuel Return Line	914 356 513 02	\$164.42	--	--	--
47 Grommet - Fuel Line Firewall	914 356 201 00	\$8.50	--	--	--
48 Grommet - Fuel Line Firewall	914 356 202 00	\$8.50	--	--	--

* All Rebuilt Parts Require A Rebuildable Core - (1) Stainless

914 & 914-6 Fuel System

Tech Tip 156: Although the 914-6 air cleaner looks similar to the 911 counter part, the 914-6 air cleaner is made flatter so it will fit under the 914 engine lid. If fitted, a 911 air cleaner will hit the 914 engine lid.

Tech Tip 159: Increasing the 914-6 main jets from 110 to 125 will result in increased top end power.

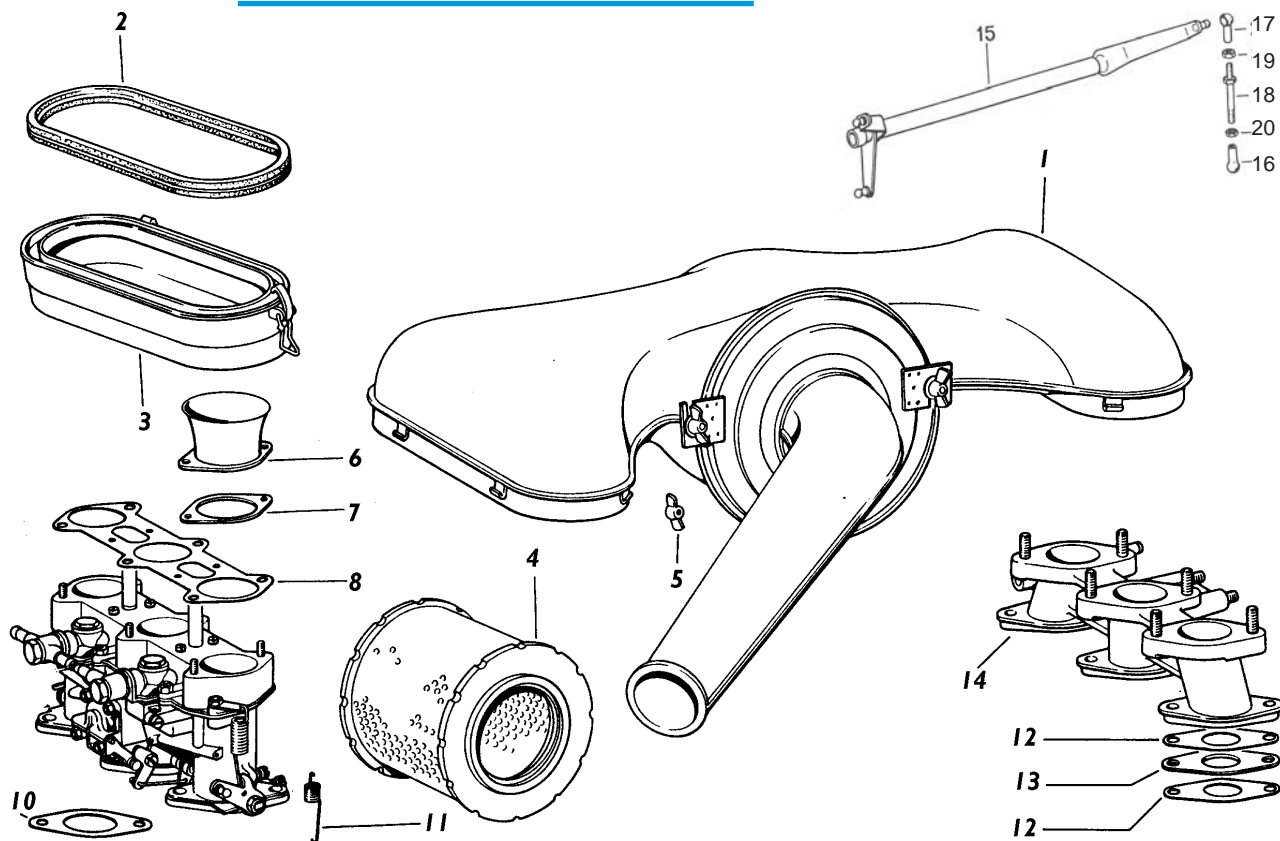

Description	Part Number	Gen.	Repl.	Used	Rep./Reb.
1 Air Filter System	901.108.022.01	\$532.75	--	\$350.00	--
2 Gasket	901.108.214.03	\$29.87	--	--	--
3 Connecting Piece	911.108.014.00	\$263.39	--	\$150.00	--
4 Air Filter	901.108.955.11	\$39.80	\$23.10	--	--
5 Wing Nut M8	900.029.003.02	\$4.58	--	--	--
6 Socket	911.108.322.01	--	\$24.00	--	--
7 Gasket	911.110.391.00	\$1.48	--	--	--
8 Gasket	901.108.218.00	\$5.57	--	--	--
9 Carburetor	901.108.125.01	\$2,351.43	\$1,093.78	\$750.00	--
10 Gasket For Carburetor	901.108.398.01	\$10.95	\$4.59	--	--
11 Tension Spring	901.108.631.00	\$8.92	--	--	--
12 Intake Manifold Gasket	901.108.391.04	\$10.94	\$4.59	--	--
13 Intermediate Flange	901.108.131.00	\$18.77	--	--	--
14 Intake Manifold (Type 901/36/38)	901.108.039.04	\$684.21	--	\$350.00	--
Intake Manifold (Type 901/37/39)	905.108.031.04	\$684.21	--	\$350.00	--
15 Crossbar	911.108.071.01	\$244.68	--	--	--
16 Ball Socket, Left Thread	900.169.010.02	\$8.43	--	\$4.50	--
17 Ball Socket	900.169.001.02	\$8.40	--	--	--
18 Link Rod	901.108.089.00	\$45.37	--	--	--
19 Nut, Left Thread	900.076.029.02	\$2.00	--	--	--
20 Nut	900.076.027.02	\$2.00	--	--	--

914 HARD PARTS

Description	Part Number	Gen.	Repl.	Used	Rep./Reb.
1 Gear Box Housing	914 301 010 01	\$748.59	--	\$75.00	--
11 Cheese Head Screw M 10x110, 914-6	900 067 074 02	\$4.90	\$2.89	--	--
Bolt, Hex Hd M 10x115, 914-4	N0 105 003	\$4.65	\$2.31	--	--
12 Bolt, Hex Hd M 10x72	900 155 023 02	\$4.41	\$2.30	--	--
13 Ft. Trans Mainseal	113 311 113 B	\$18.48	\$10.60	--	--
14 Reverse Light Switch Boot	914 613 491 00	\$11.02	--	--	--
15 Reverse Light Switch	914 613 541 02	\$88.40	\$69.75	\$30.00	--
16 Lock Washer 2.3	N0 124 321	\$1.00	\$1.00	--	--
17 Reverse Light Pin	901 303 017 01	\$8.77	--	--	--
18 Final Drive Seal	999 113 183 40	\$16.37	\$9.30	--	--
19 Mainshaft Bearing	999 053 025 00	\$384.78	\$259.88	--	--
20 Pinion Shaft Bearing	999 052 016 00	\$384.78	\$150.10	--	--
21 Intermediate Plate	901 301 035 13	\$357.29	--	\$200.00	\$475.00
22 Washer	914 303 173 00	--	--	--	\$5.44
23 Joint Ring	900 112 011 50	--	--	--	--
24 Closing Screw	999 064 020 02	\$12.86	--	--	--
25 Ball Lever	914 303 129 00	\$60.24	--	--	--
26 Clamping Pin	900 309 001 00	\$4.50	--	--	--
27 O Ring	999 701 359 40	\$6.67	\$2.88	--	--
28 Support Block	914 303 127 01	\$334.84	--	--	--
29 Shift Sleeve	914 424 224 02	\$20.50	\$11.55	--	--
30 Washer 8,4	900 031 001 02	\$1.00	--	--	--
31 Pin For Return Lever	914 301 307 00	\$17.05	--	--	--
32 Bush M 8x9	999 504 040 02	\$1.82	--	--	--
33 Washer 8,4	900 025 007 02	\$1.00	\$1.00	--	--
34 Ball Pin	901 116 771 01	\$34.84	--	\$21.20	--
35 Guide Tube	901 116 087 11	\$233.97	\$175.07	\$80.00	--
36 Throw Out Bearing	901 116 081 11	\$304.85	\$109.30	\$50.00	--
37 Throw Out Bearing Clip	901 116 825 11	\$5.92	\$5.77	\$2.50	--
38 Disengaging Fork	901 116 712 00	\$476.70	--	\$220.00	--
39 Ball Stud Clip	901 116 077 01	\$7.62	--	--	--
40 Ball Stud Cup	901 116 741 01	\$9.00	\$5.77	--	--
41 Shift Lever Shaft 1970-72	914 303 301 01	\$157.83	--	\$75.00	--
42 Shift Lever Shaft	914 303 011 02	\$189.64	--	\$90.00	--
43 Trans Gear Gasket	901 301 392 12	\$3.48	--	--	--
44 Transmission Mounting, 914-6	914 375 026 00	\$164.06	--	\$75.00	--
Transmission Mounting, 914-4	914 375 025 00	\$177.09	\$89.60	\$75.00	\$97.90
45 Ground Strap	999 611 919 20	\$19.95	--	--	\$7.15
46 Rear Trans Cover, 914-6	914 301 031 02	\$667.50	--	\$475.00	--
Rear Trans Cover, 914-4 1973-76	914 301 032 00	\$672.71	\$410.03	--	--
Rear Trans Cover, 914-4	914 301 031 03	\$672.71	--	\$150.00	--
47 Bolt, Hex Hd M 12x1.5x125	900 082 044 02	\$16.12	--	--	--
48 Stud, Bm 8x16	N0 145 325	\$9.68	\$3.46	--	--
49 Bolt, Hex Hd	901 318 272 03	\$7.50	--	\$6.00	--

Description	Part Number	Gen.	Repl.	Used	Rep./Reb.
50 Shaft For Speedometer Drive	914 318 333 10	\$91.52	--	\$40.00	--
51 Speedo Angle Drive Seal	999 701 084 50	\$3.11	--	--	--
52 Gasket	914 301 391 00	\$2.50	--	--	--
53 Cover For Rear Transmission Cover	914 301 313 00	\$10.62	--	\$6.00	--
54 Speedo Angle Drive	914 318 029 01	\$151.36	\$86.00	\$35.00	--
55 Double Roll Pin	900 309 003 00	\$4.50	--	--	--
56 Driving Shaft & Gear 914-6	911 302 907 00	\$2,593.04	--	\$650.00	--
Driving Shaft & Gear 914-4	016 311 103	\$1,768.89	--	\$650.00	--
57 Drive Shaft W/ring Gear 914-4	901 302 901 01	\$4,669.50	--	\$850.00	--
58 Main Shaft Bearing	999 110 014 00	\$495.69	\$379.50	--	--
59 Locking Plate	999 038 001 00	\$2.00	--	--	--
60 Hexagon Nut	999 183 001 00	\$4.64	--	--	--
61 1st Reverse Slider	911 302 226 00	\$695.12	\$415.00	--	--
62 2nd/3rd Or 4th/5th Slider	911 302 411 10	\$259.62	\$170.85	--	--
63 Cylindrical Roller Bearing	999 110 813 00	\$384.78	\$202.12	--	--
65 Synchronizing Ring 1st — 5th Speed	911 302 301 06	\$85.54	\$82.50	--	--
66 Needle Cage 1st — 5th Speed	999 201 138 00	\$101.34	--	\$50.00	--
67 1st Speed (Dogteeth Only)	911 302 903 00	\$1,580.20	--	--	--
68 2nd-5th (Dogteeth Only)	901 302 224 106	--	\$127.00	--	--

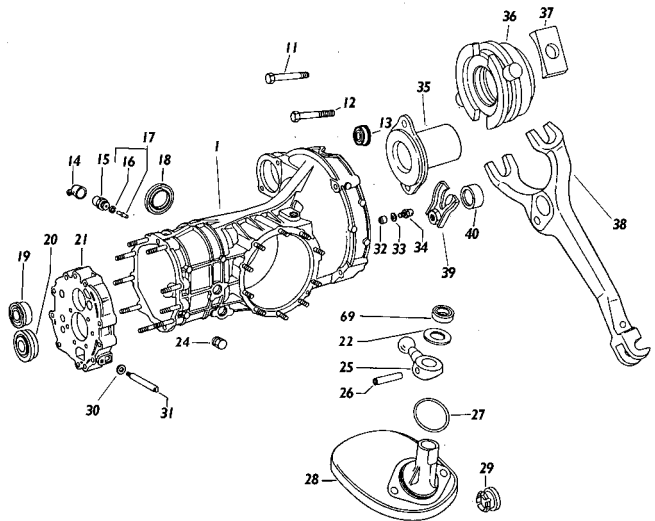

Tech Tip 167: If the throwout bearing arm moves back as far as hitting the transmission case and the clutch will not release, you will need to remove the transmission and examine the clutch assembly.

Tech Tip 177: If your 914 cranks slowly after a clutch job, you forgot to connect the rear transmission ground strap.

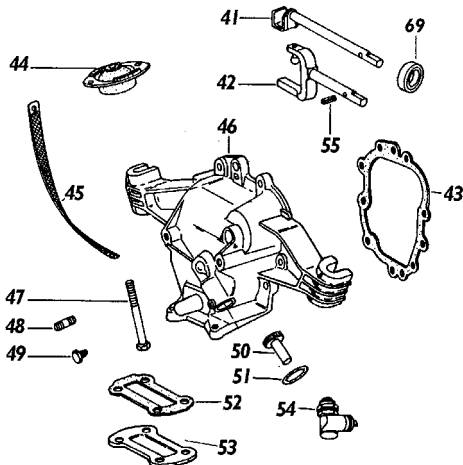

914 & 914-6 Transmission

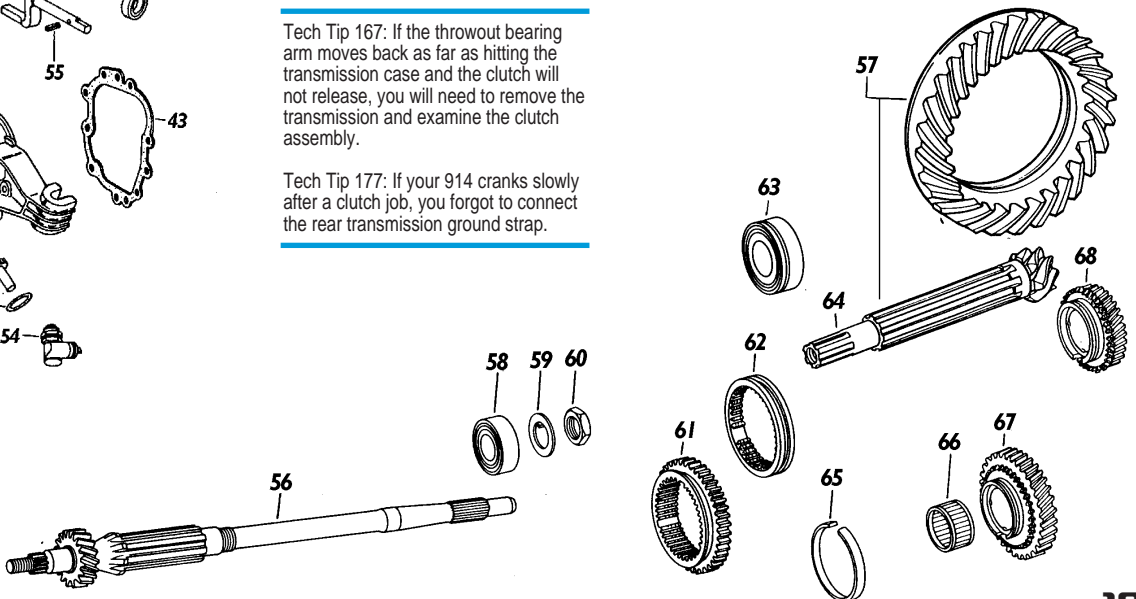

914 & 914-6 Front Axle & Steering

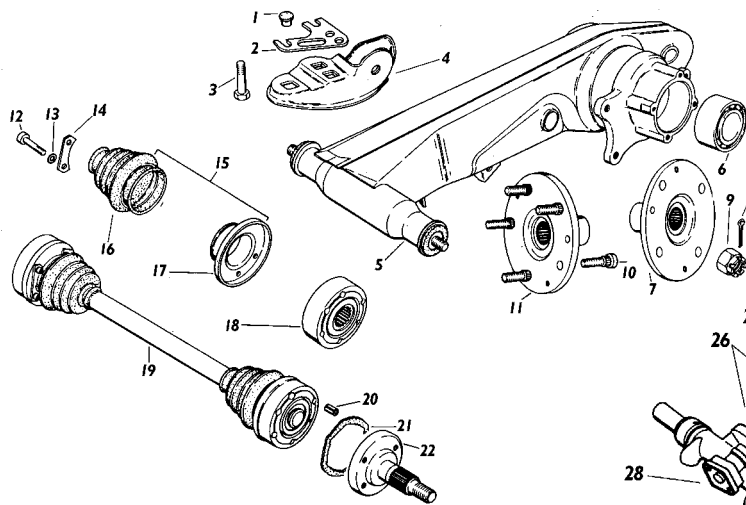

Tech Tip 254: A clicking noise while under way is caused by a dry CV joint. These dry or worn joints can also cause a vibration in the seat of your pants. 30,000 mile re-packing and inspection of the joints is a must.

Tech Tip 264: Always install new CV joint gaskets when replacing the joint. The gasket keeps the grease from slinging out of the joint and helps lock the joint to the output flange.

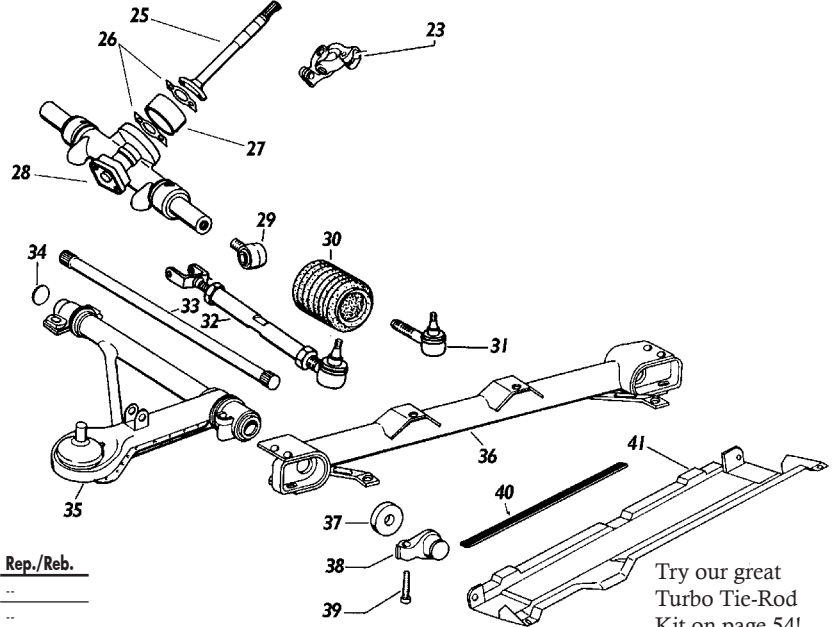

Try our great Turbo Tie-Rod Kit on page 54!

Description	Part Number	Gen.	Repl.	Used	Rep./Reb.
1 Closing Plug	914 331 520 00	\$3.00	--	--	--
2 Alignment Shim, 2mm	914 331 533 03	\$31.29	--	\$20.00	--
Alignment Shim, 3mm	914 331 533 04	\$31.30	--	\$20.00	--
Alignment Shim, 4mm	914 331 533 05	\$32.00	--	\$25.00	--
3 Bolt, Hex Hd, M10x55	NO 104 553	\$2.20	\$2.00	--	--
4 Control Arm Bracket	914 331 052 01	\$44.74	--	\$25.00	--
5 Rear Control Arm, Left, 914-6 (Op 914-4)	914 331 057 02	\$476.84	--	\$250.00	--
Rear Control Arm, Left, 914-4	914 331 057 03	\$498.72	--	\$200.00	--
Rear Control Arm, Left, 914-6	914 331 058 02	\$457.45	--	\$200.00	--
Rear Control Arm, Right, 914-4	914 331 058 03	\$457.45	--	\$200.00	--
6 Rear Wheel Bearing	443 407 625	\$102.85	\$52.74	--	\$35.00
7 Rear Wheel Hub, 4 Holes	914 331 605 07	\$215.91	--	\$125.00	--
8 Split Pin 4x40	900 021 024 00	--	\$1.00	--	--
9 Castellated Nut	901 332 806 00	\$18.75	--	\$10.50	--
10 Wheel Stud For 5 Hole Hub	904 341 671 00	\$8.28	--	\$5.00	--
11 Rear Wheel Hub W/studs 914-6	901 331 065 09	\$731.11	--	\$300.00	--
12 Cv Joint Bolt, M8x45, 914-6	900 067 073 01	--	\$2.30	\$2.00	--
Cv Joint Bolt, M8x46, 914-4	113 501 229 D	\$2.73	\$2.30	\$2.00	--
13 Locking Washer M8	999 523 102 01	\$2.00	\$1.15	--	--
14 Base Plate, 914-6	901 332 191 00	\$3.02	--	\$1.00	--
Base Plate, 914-4	901 332 191 00	\$3.02	--	\$1.00	--
15 Sleeve	914 332 035 00	\$37.74	\$22.52	--	--
16 Dust Bellows	901 332 293 10	\$16.03	\$8.00	--	--
17 Cover	914 332 228 01	\$51.60	--	--	--
18 CV Joint	914 332 029 03	\$243.07	--	--	--
19 CV Axle, Compl. 914-4	914 332 009 03	\$355.02	--	\$250.00	\$199.00
CV Axle, Compl. 914-6	914 332 009 00	\$355.02	--	\$250.00	\$199.00
20 Spiral Pin S10x20	999 095 019 00	\$3.50	--	\$2.00	--
21 CV Joint Gaskets	914 332 237 01	\$4.20	\$2.00	--	--
22 Stub Axle, 914-6	914 332 223 00	\$690.16	--	--	\$342.00
Stub Axle, 914-4	914 332 223 01	\$279.01	--	\$100.00	--
23 Universal Joint	914 347 025 01	\$144.00	--	\$75.00	--

Description	Part Number	Gen.	Repl.	Used	Rep./Reb.
24 Steering Shaft Mounting	911 347 029 00	\$92.46	--	\$50.00	--
25 Steering Shaft	914 347 210 00	\$104.62	--	\$25.00	--
26 Lock Plate	901 347 248 00	\$5.01	--	--	--
27 Steering Coupling	901 347 201 02	\$92.19	--	\$38.00	--
28 Rack And Pinion Steering Gear	914 347 010 05	\$961.32	--	\$475.00	--
29 Inner Tie Rod	914 347 057 00	\$54.10	--	\$20.00	--
30 Dust Boot	901 347 191 02	\$38.34	\$23.00	--	--
31 Outer Tie Rod End	911 347 322 04	\$41.75	\$19.90	\$10.00	--
32 Tie Rod	911 347 031 00	\$136.21	\$67.00	\$20.00	--
33 Torsion Bar, Left, 914-6	914 343 101 00	\$166.04	--	\$95.00	--
Torsion Bar, Right, 914-6	914 343 102 12	\$183.92	--	\$95.00	--
Torsion Bar, Left, 914-4	914 343 107 00	\$161.64	--	\$95.00	--
Torsion Bar, Right, 914-4	914 343 108 00	\$166.00	--	\$95.00	--
34 Closing Disk	900 040 008 01	\$12.45	--	--	--
35 Transverse Link, W/o Ball Joint, Left 914-6	911 341 901 00	\$557.38	--	\$250.00	--
Transverse Link, W/o Ball Joint, Right 914-6	911 341 902 00	\$557.38	--	\$250.00	--
Transverse Link, W/o Ball Joint, Left 914-4	914 341 001 05	\$466.99	--	\$250.00	--
Transverse Link, W/o Ball Joint, Right 914-6	914 341 002 04	\$467.91	--	\$250.00	--
36 Front Suspension Support, 914-6	901 341 013 03	\$182.38	--	\$75.00	--
Front Suspension Support, 914-4	914 341 013 03	\$177.18	--	\$50.00	--
37 Gasket	901 341 475 00	\$4.12	--	--	--
38 Adjusting Lever, 914-6	901 341 033 00	\$99.70	--	\$25.00	--
Adjusting Lever, 914-4	914 341 033 00	\$158.90	--	\$25.00	--
39 Adjusting Screw	911 341 115 00	\$38.72	--	\$15.00	--
40 Rubber Profile	901 341 165 00	\$75.00	--	\$50.00	\$45.00
41 Lower Protecting Plate	914 341 161 00	\$328.76	--	\$150.00	--

Tech Tip 255: A rear whine that varies in tone when the steering wheel is moved from side to side, while coasting with the shifter in neutral, is a sign of a bad rear wheel bearing. These one piece inner and outer sealed assemblies usually last 125,000 miles and are permanently lubricated.

Tech Tip 263: Original CV joint boots are pressed into their own flange. If renewing them with a replacement boot, the boot must be clamped to the outside of the flange. Or you can buy a boot with the built-in flange as a replacement.

914 HARD PARTS

914 & 914-6 Front Axle & Steering

\$\$\$	Part Number	Gen.	Repl.	Used	Rep./Reb.
1	914 613 805 12	\$484.28	--	\$250.00	--
2	901 347 823 01	\$10.52	--	--	--
3	914 347 831 00	\$22.20	--	--	--
3	914 347 832 00	\$23.53	--	--	--
4	914 347 803 10	\$999.15	--	\$250.00	--
	914 347 806 10	\$1,175.34	--	--	\$195.00*
	914 347 805 11	\$1,018.64	--	--	\$192.00*
5		--	--	--	--
	914 613 303 30	\$435.95	--	\$250.00	--
6	914 613 311 00	\$47.79	--	\$30.00	--
7	901 347 061 01	\$1,432.09	--	--	--
	914 347 061 18	\$124.77	--	\$50.00	--
8	914 347 711 00	\$214.89	--	--	--
9	914 347 713 00	\$4.12	--	--	--
10	914 347 072 00	\$518.38	--	\$350.00	--
11	914 613 302 10	\$132.39	--	\$100.00	--
12	901 559 330 01	\$45.91	--	--	--
13	914 613 805 12	\$484.28	--	\$150.00	--
	914 613 805 11	\$484.28	--	\$150.00	--
14	914 347 099 00	\$35.39	--	\$15.00	--
15	914 347 090 10	\$1,018.64	--	--	--
	914 347 091 10	\$648.26	--	--	\$165.00
16		\$5.19	--	\$14.59	\$10.00
17	914 347 102 10	\$1.28	--	--	--
18		\$5.19	--	--	--
19	914 613 305 10	\$299.46	--	\$250.00	--
	914 613 306 17	\$670.20	--	\$375.00	--
	914 613 306 10	\$286.10	--	\$350.00	--
20	914 613 306 17	\$670.00	--	\$400.00	--
	914 613 306 18	\$670.20	--	\$400.00	--
21	N012 2391	\$3.50	--	--	--
22	N0111 654	\$8.50	--	--	--
23	901 613 325 05	\$77.42	--	--	--
24	111 953 535 D	--	\$6.50	--	--

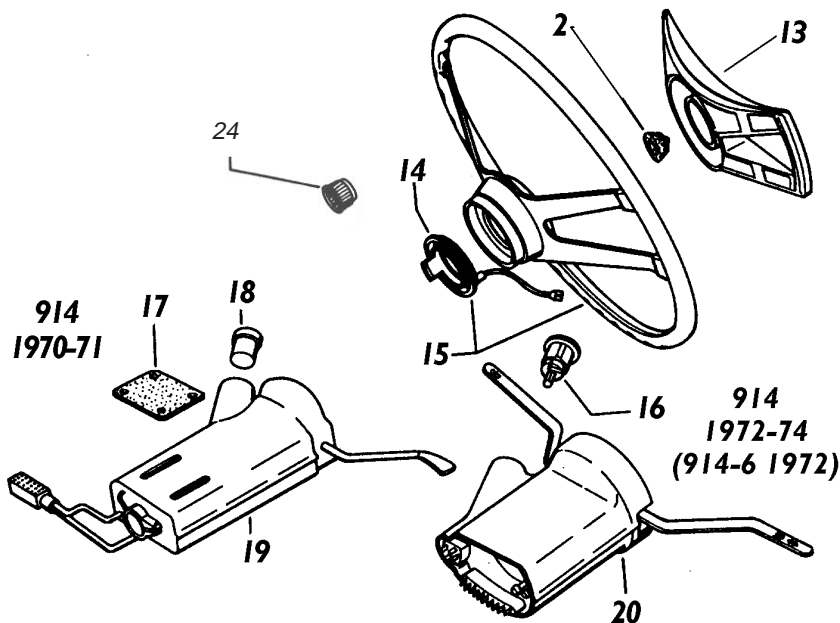
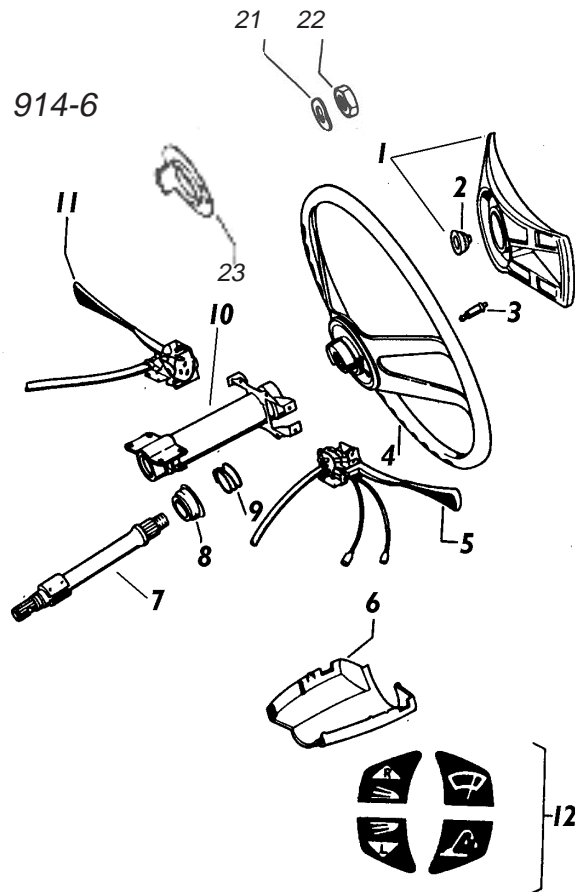

914 & 914-6 Front & Rear Axle

Description	Part Number	Gen.	Repl.	Used	Rep./Reb.
1 Hexagon Nut M14x1.5	N 011 0213	\$4.32	\$1.16	--	--
2 Locking Plate	900 038 002 01	\$2.51	--	--	--
3 Supporting Washer	901 341 629 00	\$9.06	\$5.77	\$2.00	--
4 Mounting W/rubber	911 341 018 00	\$173.17	--	\$85.00	--
5 Protective Tube	914 341 086 00	\$26.81	--	\$5.00	--
6 Rubber Spring (Boge)	901 343 301 00	\$27.98	\$17.39	--	--
7 Replacement Shock Absorber	914 341 903 00	\$229.64	\$89.50	\$25.00	--
8 Closing Screw	914 341 804 00	\$41.06	--	\$20.00	--
9 Left Shock Absorb, Outer To 1972	914 341 081 02	\$436.41	--	\$250.00	--
Right Shock Absorb, Outer To 1972	914 341 082 02	\$419.33	--	\$250.00	--
Left Shock Absorb, Outer From 1973	914 341 081 05	\$509.36	--	\$200.00	--
Right Shock Ab., Outer From 1973	914 341 082 05	\$519.55	--	\$295.00	--
10 Shock Absorber, Left, Boge 914-6	914 341 091 00	\$501.08	--	\$375.00	--
Shock Absorber, Right, Boge 914-6	914 341 092 00	\$501.08	--	\$375.00	--
Shock Absorber, Lft, Bilstein 73-76 914	914 341 091 34	\$569.23	--	\$450.00	--
Shock Absorber, Rt, Bilstein 73-76 914	914 341 092 34	\$596.77	--	\$450.00	--
11 Ball Pin Joint 73-76 914	911 341 119 06	\$20.78	\$16.00	--	--
12 Balljoint, 914-4 From 1973	911 341 049 01	\$105.19	\$54.46	--	--
Balljoint, 914-6/4 Up To 72	901 341 049 00	\$112.61	\$85.38	--	--
13 Groove Nut	901 341 425 00	\$22.45	--	\$10.00	--
14 Locking Plate	901 341 426 00	\$11.68	--	--	--
15 Split Pin, 2x20	900 075 111 08	\$3.23	\$1.46	--	--
16 Ball Joint Bolt 10x30	900 075 111 08	\$3.75	\$3.46	--	--
17 Seal	999 701 084 50	\$3.11	--	--	--
18 Distance Ring	901 341 623 00	\$51.28	--	--	--
19 Radial Seal Ring 914-6	311 405 641 B	\$14.00	\$4.50	--	--
Radial Seal Ring 914-4	311 405 641 B	\$6.95	\$4.50	--	--
20 Inner Wheel Bearing, 914-6	999 059 098 00	\$23.62	\$7.70	--	--
Inner Wheel Bearing, 914-4	311 405 625 D	\$39.09	\$6.60	--	--
21 Front Suspension Hub 914-6	901 341 065 04	\$323.37	--	--	--
22 Outer Wheel Bearing 914-6	999 059 098 00	\$23.62	\$7.70	--	--
Outer Wheel Bearing 914-4	311 405 645	\$25.82	\$9.63	--	--
23 Washer, 914-6	901 341 663 00	\$4.96	--	--	--
Washer, 914-4	311 405 661	\$4.23	--	--	--
24 Front Axle Nut, 914-6	914 341 671 00	\$49.01	--	--	--
Front Axle Nut, 914-4, Left	131 405 669	\$29.00	--	\$18.00	--
Front Axle Nut, 914-4, Right	131 405 670	\$25.56	--	\$18.00	--
25 Rubber Ring	421 839 455	\$8.78	--	--	--
26 Cap For Front Wheel Hub, 914-6	914 341 684 00	\$19.01	--	\$9.00	--
Cap For Front Wheel Hub, 914-4	111 405 691 B	\$13.97	--	\$9.00	--
27 Cheesehead Screw	999 119 001 01	\$1.38	\$1.00	--	--
28 Rear Sway Bar Mounting Plate 1970-74	914 501 259 11	\$66.04	--	--	--
Rear Sway Bar Mounting Plate 1975-76	914 507 027 10	\$45.87	--	--	--
29 R Sway Mount. Plate Reinforcement	914 501 532 71	\$10.62	--	--	--
30 R. Sway Bar Bushing	901 333 793 01	\$49.60	--	--	\$20.00
31 R. Sway Bar	914 333 055 06	\$456.65	--	\$150.00	--
32 R. Sway Bar Link	914 333 057 00	\$65.00	--	\$40.00	--
33 R. Sway Bar Link Bushing	901 343 782 00	\$17.00	\$8.70	--	--
34 Link To Frame Mount	914 333 565 01	\$134.22	--	\$85.00	--
35 Shock Stop	914 333 053 01	\$78.71	--	--	--
36 Stop Washer	901 333 511 00	\$4.22	--	--	--

Tech Tip 219: When installing the original factory or aftermarket through-the-body front sway bar, make sure your transverse links have the factory "U" brackets welded to them. Before installing the bar, weld the factory triangular reinforcement nut plates into the inner wheel house. These plates keep the sway bar from tearing the wheel house.

Description	Part Number	Gen.	Repl.	Used	Rep./Reb.
37 Cap (Boge)	914 333 503 00	\$7.21	--	--	--
38 Spring Plate, Lower, Boge	914 333 521 01	\$201.41	--	\$106.00	--
Spring Plate, Lower, Bilstein	914 333 521 04	\$122.70	--	--	--
39 Shock Absorber, Boge, 914-6	914 333 051 01	\$186.65	\$90.00	\$25.00	--
Shock Absorber, Boge, 914-4	914 333 051 02	\$205.09	\$86.62	\$25.00	--
Shock Absorber, Bilstein	914 333 051 31	\$268.27	\$144.37	\$150.00	--
40 Circlip Bilstein	999 041 310 01	\$8.50	--	--	--
41 Trailing Spring, 914-6	914 333 531 05	\$423.50	--	\$125.00	\$115.00/set
Trailing Spring, 914-4	914 333 901 00	\$259.66	--	\$25.00	\$115.00/set
42 Spring Plate, Upper	914 333 522 01	\$113.48	--	\$10.00	--
43 Washer	914 333 515 01	\$2.60	--	--	--
44 Threaded Bushing	914 333 516 00	\$27.20	--	\$10.00	--
45 Shock Bushing Lower Rear	914 333 513 01	\$75.00	--	\$25.00	--
46 Shock Bushing Upper Rear	914 333 514 01	\$75.00	--	\$25.00	--
47 Washer	914 333 515 00	\$7.27	--	\$4.00	--
48 Hexagon Nut, 914-6	900 910 042 02	\$2.00	\$1.15	--	--
Hexagon Nut, 914-4	900 910 042 02	\$2.00	\$1.15	--	--
49 Cap	914 559 281 10	\$55.13	--	\$20.00	--
50 Shackle	914 343 075 00	\$81.16	--	\$45.00	--
51 Sway Bar Link Bushing	901 343 783 00	\$8.11	--	--	\$21.40/set
52 Stabilizer Lever	901 343 713 01	\$114.10	--	\$85.00	--
53 Bolt, Hex Hd M8x25	900 075 029 09	\$2.01	\$1.15	--	--
54 Spring Ring B8	900 027 015 02	\$1.00	\$2.00	--	--
55 Stabilizer Mounting	901 343 754 01	\$94.02	--	\$50.00	--
56 Sway Bar To Body Bushing	901 343 792 02	\$37.60	--	--	\$20.00
57 Stabilizer	901 343 703 03	\$274.97	--	\$100.00	--
58 Front Swaybar Reinforce Plate	914 501 162 10	\$25.66	--	--	--

914 HARD PARTS

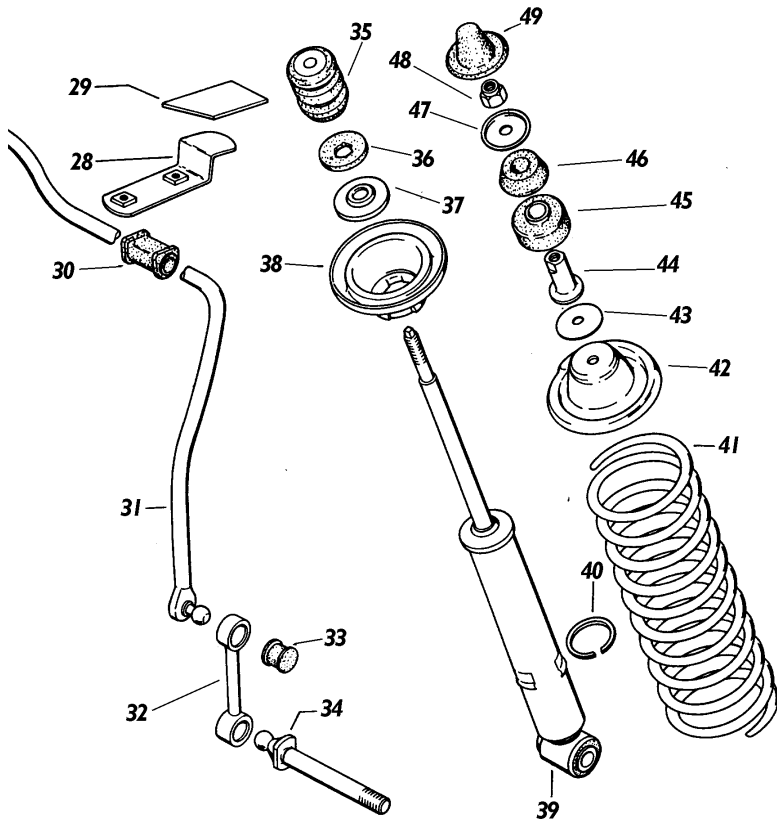
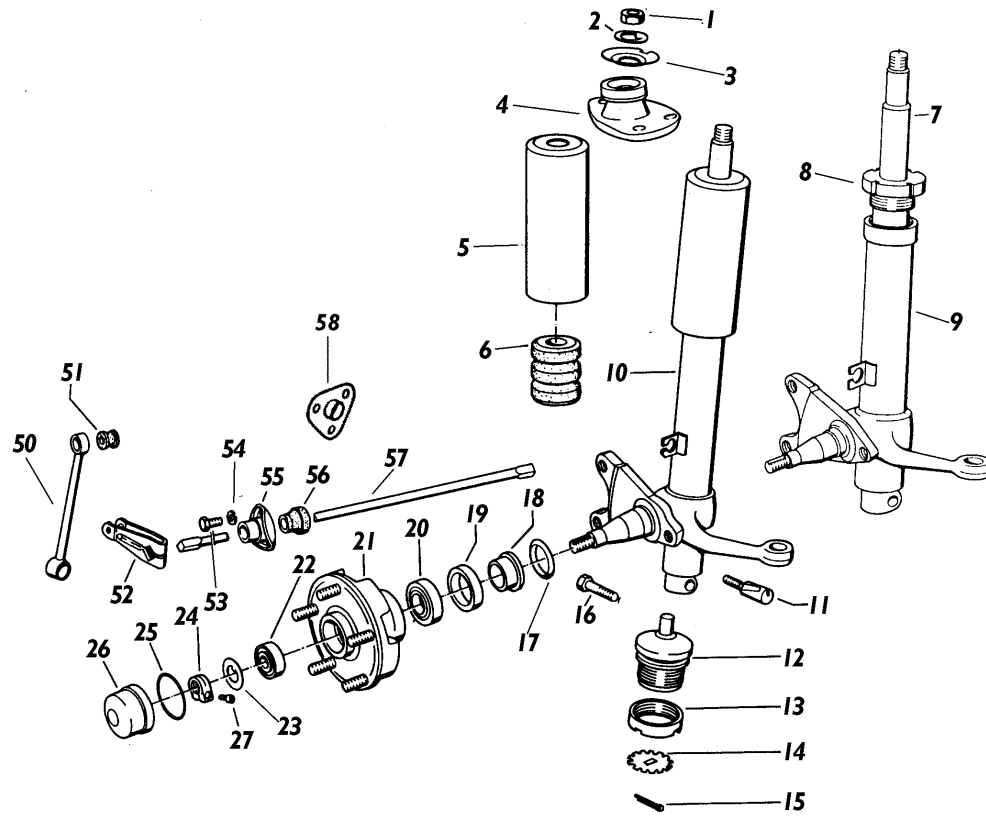

Description	Part Number	Gen.	Repl.	Used	Rep./Reb.
1 Rear Brake Disc 914-6	901 352 401 18	\$301.62	\$105.00	\$70.00	--
Rear Brake Disc 914-4	914 352 401 10	\$176.54	\$73.18	--	--
2 Countersunk Screw 6x12	900 269 047 09	\$1.00	\$1.00	--	--
3 Dust Cap	211 611 483	\$4.99	\$3.28	--	--
4 Breather Valve	901 352 977 10	\$8.50	--	--	--
5 Rear Brake Caliper, Left, 914-6	914 352 901 00	\$1,735.58	--	--	\$302.00*
Rear Brake Caliper, Right, 914-6	914 352 902 00	\$1,735.13	--	--	\$302.00*
Rear Brake Caliper, Left, 914-4	914 352 423 00	\$1,940.72	--	--	\$181.00*
Rear Brake Caliper, Right, 914-4	914 352 424 00	\$1,866.26	--	--	\$181.00*
6 Protection Cap, 914-6	914 352 906 00	\$6.43	--	--	--
Protection Cap, 914-4	901 352 937 10	\$7.30	--	--	--
7 Clamping Ring, Rear, 9114-6	901 352 988 00	\$3.41	--	--	--
Clamping Ring, Rear, 914-4	914 352 926 00	\$3.86	--	--	--
8 Brake Pad Set, Rear, 914-6 Pads Only	914 352 903 00	\$94.59	\$45.00	--	--
Brake Pad Set, Rear, 914-4 Pads Only	914 352 923 00	\$92.39	\$35.14	--	--
9 Brake Pad Clip, Rear, 914-6	914 352 908 00	\$16.24	--	\$8.00	--
Brake Pad Clip, Rear, 914-4	311 615 269	\$16.28	--	\$8.00	--
10 Reservoir Cap	477 611 361	\$19.04	\$9.20	\$6.00	--
11 Strainer	211 611 381 B	\$3.75	--	\$4.00	--
12 Brake Master Cyl. Reservoir, 914-6	911 355 013 13	\$32.58	--	\$17.00	--
Brake Master Cyl. Reservoir, 914-4	911 355 013 13	\$32.58	--	\$17.00	--
13 Hose Piece, 50mm, 914-6, "Blue"	999 181 021 50	\$27.64	\$5.50	--	\$22.00
Hose Piece, 50mm, 914-4, "Blue"	111 611 802	\$10.82	\$3.46	--	--
14 Hose Clip	999 512 055 02	\$2.37	\$1.73	--	--
15 Connecting Line - Ft. Brake Circuit	914 355 063 00	\$89.20	--	\$35.00	--
15A Connecting Line - Ft. Brake Circuit	914 355 063 00	\$99.20	--	\$35.00	--
16 Fuel Line Grommet	111 957 861	\$6.50	--	--	--
17 Connecting Line - Rear Brake Circuit	914 355 063 00	\$99.20	--	\$35.00	--
18 Master Cylinder Grommet	901 355 929 00	\$4.86	--	--	--
19 Reverse Light Switch Boot	914 613 491 00	\$11.02	--	--	--
20 Brake Warning Light Switch (Two Pole)	901 613 115 00	\$83.92	--	\$20.00	--
Brake Warning Light Switch (Single Pole)	914 613 116 00	\$52.55	\$52.55	\$25.00	--
21 O Ring 12.42x1.78	999 701 343 40	\$2.30	--	--	--
22 Tandem Master Cyl. W/warning Device 914-6	911 355 012 00	\$309.76	\$161.12	\$45.00	--
Tandem Master Cyl. W/warning Device 914-4	914 355 012 00	\$305.17	\$192.40	--	--
24 Protection Cap, Master Cyl.	901 355 924 00	\$10.48	--	\$12.87	--
25 Front Brake Disc, 914-6	911 351 041 20	\$139.18	\$76.00	\$33.00	--
26 Ft Brake Disc, 914-4 Up To 1972 Chassis 472 291 9032	411 407 075	\$210.62	\$60.00	--	--
Ft Brake Disc, 914-4 1972 Ch.472 291 9033-473 290 2510	411 407 075 B	\$202.08	\$65.94	--	--
Ft Brake Disc, 914-4 From 1973 Chassis 473 290 2511	411 407 075 B	\$202.08	\$65.94	--	--
27 One Set Front Brake Pads, 914-6	901 351 963 25	\$98.19	\$51.97	--	--
One Set Front Brake Pads, 914-4 (Up To 1972)	914 351 903 00	\$195.66	\$40.42	--	--
One Set Front Brake Pads, 914-4 (Fr. 1972)	914 351 905 01	\$195.66	\$40.42	--	--

Description	Part Number	Gen.	Repl.	Used	Rep./Reb.
28 Caliper Repair Kit, 914-6, Front	901 351 964 11	\$29.80	\$20.30	--	--
Caliper Repair Kit, 914-4 (Up To 1972)	411 698 471	\$49.50	\$29.64	--	--
Caliper Repair Kit, 914-4 (From 1972)	PCG 698 471	\$189.00	\$21.00	--	--
29 Front Brake Caliper, Left 914-6	911 351 907 00	\$419.28	--	\$75.00	\$170.00**
Front Brake Caliper, Right 914-6	911 351 908 00	\$419.28	--	\$75.00	\$170.00**
Front Brake Caliper, Left 914-4 (Up To 72)	311 615 107 B	\$402.95	--	\$50.00	\$170.00
Front Brake Caliper, Right 914-4 (Up To 72)	311 615 108 B	\$402.95	--	\$50.00	\$181.00
Front Brake Caliper, Left 914-4 (Fr. 1972)	914 351 425 00	\$556.81	--	\$75.00	\$181.50
Front Brake Caliper, Right 914-4 (Fr. 1972)	914 351 426 00	\$556.82	--	\$75.00	\$181.50
30 Expanding Spring 914-6	901 351 916 14	\$16.06	\$12.00	\$9.00	--
Expanding Spring 914-4 Up To 1972	901 351 916 16	\$15.59	\$12.00	\$8.00	--
Expanding Spring 914-4 From 1972	411 615 269 A	\$18.50	\$12.33	\$8.00	--
31 Seal Ring, 914-6	901 351 928 00	\$3.63	\$2.30	--	--
Seal Ring, 914-4	311 615 277	\$4.10	\$2.30	--	--
32 Locking Plate	411 615 291	\$4.00	--	--	--
33 Bolt, Hex Hd M12x1.5x30	N 101 274	\$3.02	--	--	--
34 Breather Valve 914-6	901 352 977 00	\$11.49	--	--	--
Breather Valve 914-4	311 615 273	\$9.35	--	--	--
35 Dust Cap	211 611 483	\$4.99	\$3.28	--	--
36 Ft Brake Circuit Screw, 914-6 & 1970-71 914-4	901 355 351 00	\$13.91	--	--	--
37 Metal Seal 12mm 1970-76	904 355 902 00	\$2.21	--	--	--
38 Ft. Brake Circuit Socket 1970-76	914 355 531 00	\$20.32	--	--	--
39 Metal Seal, 10mm 1970-76	904 355 904 00	\$3.50	--	--	--
40 Brake Line, Ft. Left, 914-4	914 355 603 00	\$35.00	--	--	--
Brake Line, Ft. Right, 914-4	914 355 604 01	\$35.00	--	--	--
41 Front Brake Line To Caliper	914 355 603 00	\$35.00	--	--	--
42 Front Brake Hose, 914-6 & 914-4 1970-71	901 355 632 01	\$32.02	\$20.84	--	--
Front Brake Hose, 914-4, 1972-76	281 611 775 B	\$29.52	\$16.75	--	--
43 Retaining Spring, 914-4 1970-71	803 611 715	\$3.10	--	\$2.00	--
44 Holder	914 355 665 00	\$7.70	--	\$2.00	--
45 Hose Piece	914 355 691 00	\$1.45	--	--	--
46 Brake Line, Front Right	914 355 618 00	\$131.52	--	\$35.00	--
47 Rear Brake Line Circuit Center	914 355 611 00	\$17.29	--	\$10.00	--
48 Brake Line, Front Left	914 355 617 00	\$42.44	--	\$25.00	\$35.00
49 Screw	914 355 534 00	\$5.39	--	\$8.50	--
50 Brake Line, Rear Left	914 355 621 01	--	--	\$20.00	\$35.00
Brake Line, Rear Right	914 355 622 01	--	--	\$20.00	\$35.00
51 Brake Hose	211 611 775 B	\$48.43	\$28.87	\$15.00	--
52 Regulator 914-6	914 355 065 01	\$408.91	--	\$150.00	--
Regulator 914-4	914 355 065 02	\$303.86	--	\$45.00	--
53 914-6 Rear Caliper Pin	914 352 922 00	\$16.79	--	--	--
914-6 Rear Caliper Pin	914 352 921 00	\$17.09	--	--	--
914-4 Rear Caliper Pin	914 351 913 14	\$17.09	--	--	--
914-4 Rear Caliper Pin	914 352 925 00	\$19.40	--	--	--
54 914-6 Front Caliper Pin	901 351 913 16	\$19.40	--	--	--
914-4 70-72 Front Caliper Pin	411 615 261	\$19.40	--	--	--
914-4 73-76 Front Caliper Pin	411 615 261 A	\$19.40	--	--	--

*All Rebuilt.

**See our brake kits,
starting on page 188.**

914 & 914-6 Brakes & Wheels

914 HARD PARTS

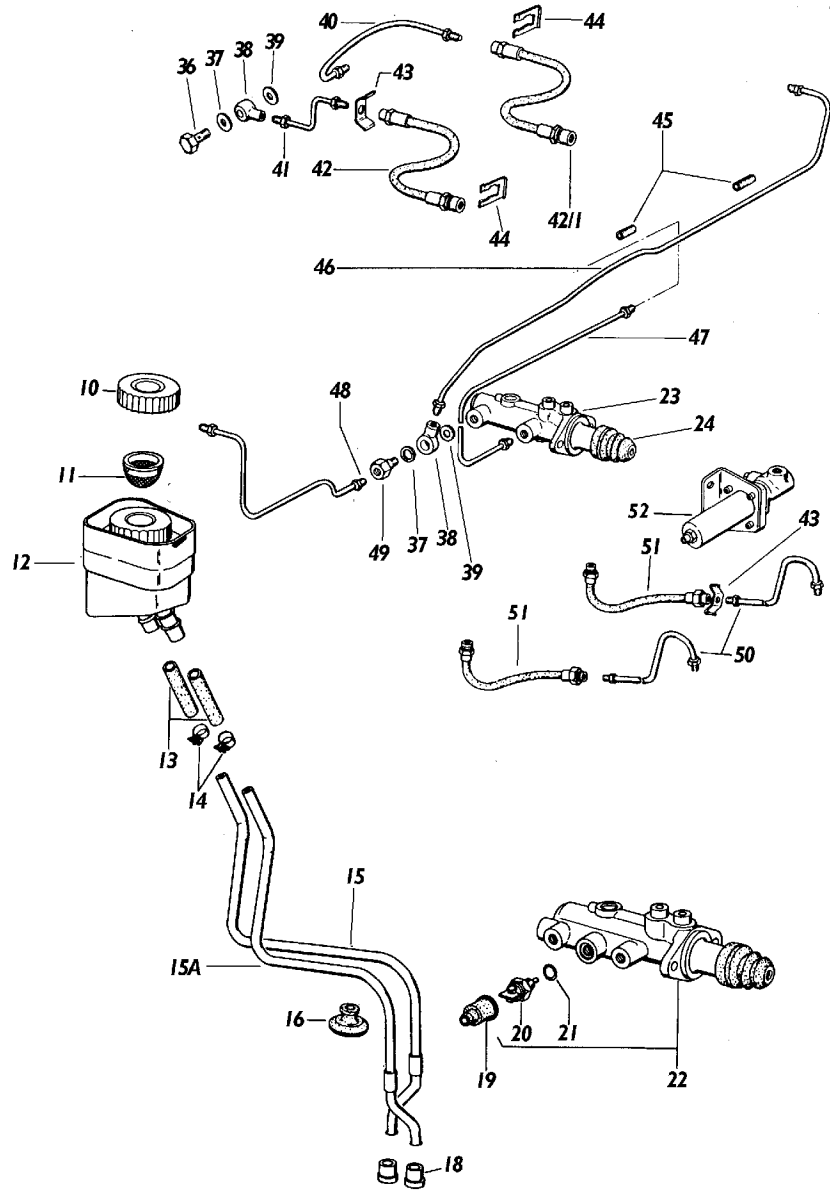
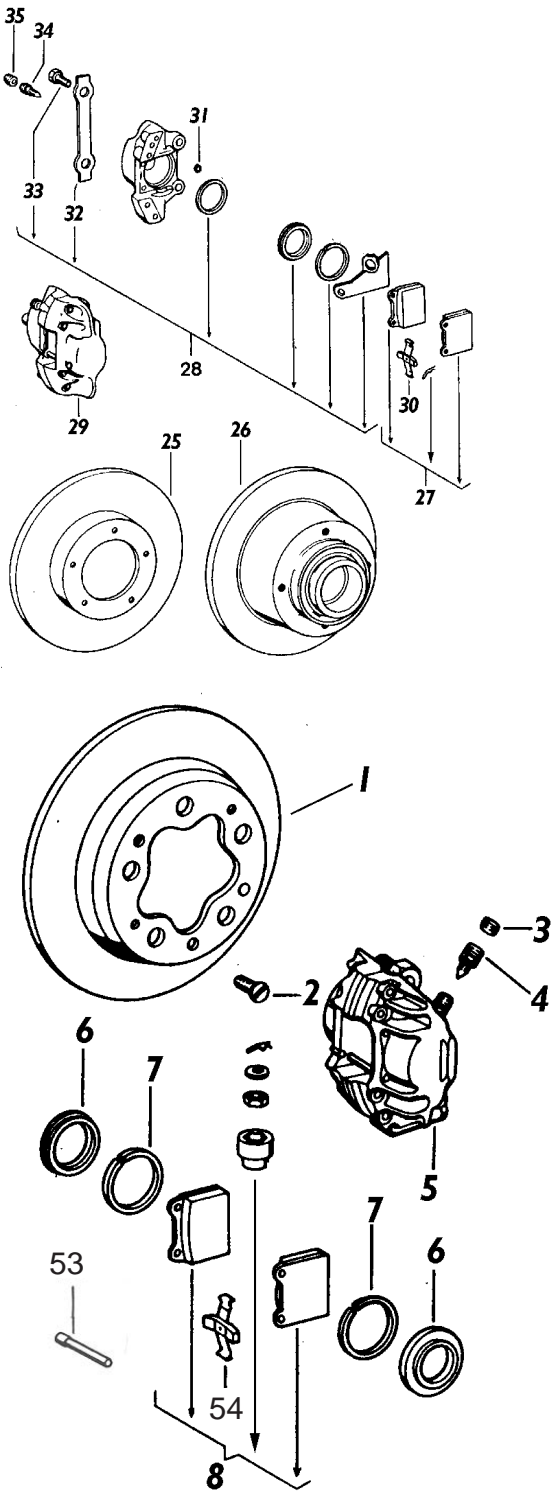

Tech Tip 302: You can easily tell which master cylinder is fitted to your 914. They are marked with the cylinder diameter on the bottom, just behind the pedal rod entry.

914 & 914-6 Brakes & Wheels

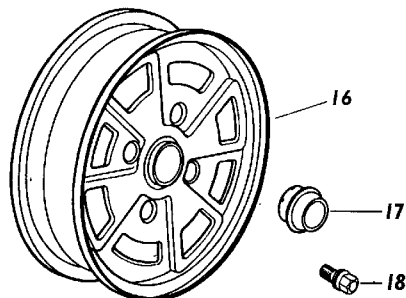
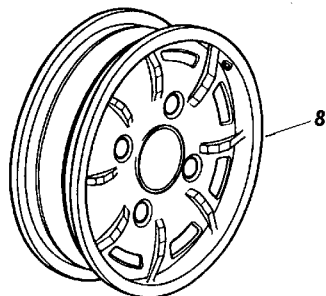
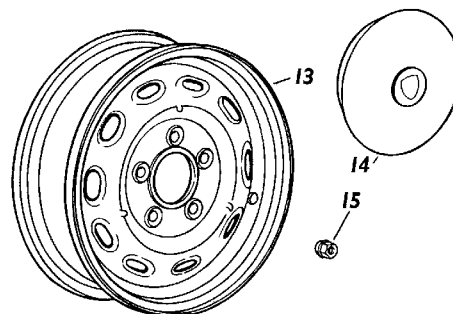
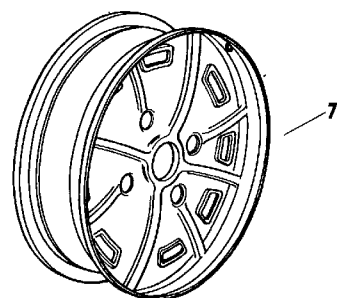
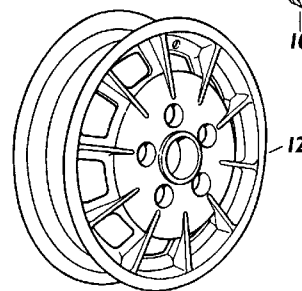
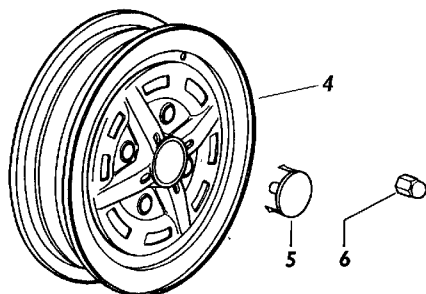
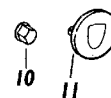
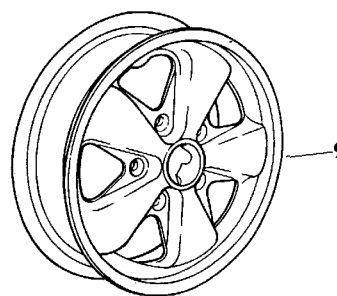
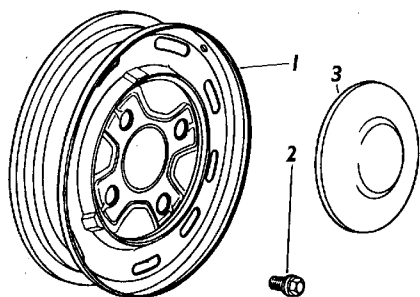

Tech Tip 316: Recommended tire sizes for the 914-4 are as follows:
 165 x 15
 185/70 x 15
 195/65 x 15
 205/60 x 15
 205/55 x 15
 These sizes all fit under the stock fender well on a stock wheel.

Tech Tip 318: Steering wheel shaking or vibration can be caused by the following:

1. Tire balance: tires with flat spots, worn out, or out of round.
2. A bent wheel.
3. Wheels that are not centered (73-76 914 models had a wheel centering disc incorporated into the front rotor).
4. Loose or worn wheel bearings.
5. Loose steering linkage (such as worn tie rod ends or steering rack play).
6. Worn CV joints.
7. Worn shock absorbers.
8. Alignment too toed in.

Description	Part Number	Gen.	Repl. Used	Rep./Reb.
1 Wheel, 4.5x15, Up To Late 1973	311 601 025 J	\$172.45	--	\$50.00 --
Slotted Wheel 5.5x15	914 361 012 02	\$175.41	--	\$75.00 --
2 Wheel Bolt, Standard Wheel	183 601 139 A	\$8.97	--	\$5.00 --
3 Hub Cap, Plain, End Of 1973	473 601 151	\$61.50	--	\$30.00 \$27.00
4 Supporting Rim 5.5x15, From 1974	914 361 016 00	\$227.58	--	\$125.00 --
5 Hub Cap, From 1974	914 361 305 00	\$15.41	--	\$4.00 \$9.50
6 Cap For Wheel Bolt, From 1974	111 601 173	\$4.62	--	-- \$3.00
7 Wheel, Pedrini, 5.5x15	914 361 013 00	\$678.44	--	\$200.00 --
8 Wheel, Mahle, 5.5x15	914 361 015 00	\$631.02	--	\$250.00 --
9 Slotted Wheel, Alum. Polished 5.5x14	911 361 016 90	\$837.42	--	\$280.00 --
Slotted Wheel, Alum. Polished 5.5x15	901 361 012 04	\$930.61	--	\$300.00 --
10 Wheel Nut	999 182 003 36	\$11.62	\$8.20	\$3.00 --
11 Hub Cap	901 361 032 00	\$44.72	--	\$18.00 \$28.29
12 Slotted Wheel, Press Casting 5.5x15	901 361 017 00	\$935.80	--	\$600.00 --
13 Slotted Wheel, 5.5x15, Silver	911 361 022 11	\$311.16	--	\$150.00 --
Slotted Wheel, 5.5x15, Primed	901 361 022 00	\$272.25	--	\$150.00 --
Slotted Wheel, 5.5x15, Chromium	901 361 015 20	\$1,206.26	--	\$350.00 --
14 Hub Cap W/Crest Varnished, Chromium	901 361 031 01	\$160.78	--	\$50.00 \$45.00 W/out Crest
Hub Cap W/Enamel Crest, Gilt-Edged	901 361 031 00	\$142.50	\$101.06	\$50.00 --
15 Wheel Nut	N0 201 121	\$6.30	\$5.00	\$4.00 --
16 Wheel, Fuchs, 5.5x15	914 361 011 01	\$980.78	--	\$250.00 \$160.00
17 Hub Cap W/Crest	914 361 303 03	\$134.50	--	-- \$82.00 W/Crest
18 Wheel Bolt, Alloy Wheel	914 361 315 01	\$22.54	--	\$14.00 \$11.00

914 HARD PARTS

Description	Part Number	Gen.	Repl.	Used	Rep./Reb.
1 Clutch Pedal, Upper Part	914 423 034 00	\$27.63	--	\$10.00	--
2 Pedal Pad	914 423 210 00	\$7.92	\$5.19	--	--
3 Bearing Bushing	911 423 341 01	\$3.51	\$2.30	--	--
4 Tube	901 423 035 00	\$89.18	--	--	--
6 Bearing Bushing (Set)	911 423 542 00	\$21.09	\$5.19	--	\$24.00 Set
7 Brake Pedal (Cluster)	901 423 053 02	\$133.44	--	--	\$275.00 Cluster
9 Brake Pedal Spring	901 423 531 00	\$27.68	--	--	--
11 Spiral Pin 56x28	900 309 002 00	\$2.00	--	--	--
12 Clutch Pedal Shaft	901 423 320 01	\$82.61	--	\$38.00	--
13 Clevis Bushing	901 423 343 00	\$5.31	\$4.60	--	--
14 Clevis Fork	900 166 002 02	\$7.16	\$6.90	--	--
15 Clevis Pin	999 166 001 02	\$8.50	\$6.90	--	--
16 Clutch Cable, 914-6	914 423 401 02	\$160.12	\$25.24	--	--
Clutch Cable, 914-4	914 423 401 05	\$48.64	\$22.50	--	--
17 Banjo Clip	914 423 283 00	\$4.67	--	--	--
18 Clutch Cable Boot	914 423 922 02	\$10.42	\$9.20	--	--
19 Clutch Pedal Spring	901 423 317 00	\$17.12	--	--	--
20 Bearing Bushing	901 423 253 00	\$2.91	\$4	--	--
21 Rubber Stop	901 423 193 00	\$1.00	--	--	--
22 Brake Light Switch	901 613 411 00	\$78.31	\$76.70	\$11	--
23 Bracket	911 423 065 02	\$126.04	--	\$40.00	--
24 Accelerator Pedal	901 423 010 00	\$84.20	\$59.50	\$35.00	\$264.00
25 Clutch Cable Roller Bracket	914 423 030 02	\$97.94	--	\$52	--

Description	Part Number	Gen.	Repl.	Used	Rep./Reb.
26 Pulley	914 423 255 02	\$25.40	--	\$12.00	--
27 Distance Bushing	914 423 273 00	\$15.20	--	\$6.00	--
28 Washer 10.5	900 025 008 09	\$1.00	\$1.00	--	--
29 Hexagon Nut	999 084 027 02	\$5.06	--	\$3.50	--
30 Clutch Pivot Wedge	911 423 205 03	\$21.83	\$16.44	\$9.00	--
31 Nyloc	No 211 931	--	\$2.00	--	--
32 Ball Socket	900 169 010 02	\$8.43	--	\$4.50	--
33 Deflector Lever, Front, 914-6	914 423 260 00	\$93.92	--	--	--
34 Hexagon Nut M5	No 110 0514	\$1.00	\$1.00	--	--
35 Accelerator Cable 914-6	914 423 066 00	\$99.53	\$65.94	--	--
36 Hexagon Nut M6	900 076 010 02	\$1.00	\$1.00	--	--
37 Washer 6.4	No 115 247	\$1.00	\$1.00	--	--
38 Hexagon Nut	914 423 287 00	--	\$1.00	--	--
39 Bracket For Accelerator Pull	914 423 285 01	\$26.41	--	--	--
40 Rubber Sleeve	914 423 593 00	\$10.66	--	--	--
41 Bolt, Hex Hd M6x16	900 075 057 02	\$1.00	\$1.00	--	--
42 Accelerator Pull Rod	901 423 026 03	\$96.79	--	--	--
43 Accelerator Pedal Rod	914 423 227 00	\$19.40	--	--	--
44 Deflection Lever, Front, 914-4	901 423 250 02	\$47.77	--	\$30.00	--
45 Accelerator Pull, 914-4	914 423 067 02	\$31.70	\$24.58	--	--
46 Acc Cable Grommet	111 971 911 A	\$7.50	--	--	--
47 Bolt, Hex Hd M5x10	No 102 056	\$1.00	\$1.15	--	--
48 Bearing Bolt	111 129 921	\$9.49	\$4.80	--	--
49 Suspension Strap	999 706 005 80	\$4.43	--	--	--
50 Bell Crank Bushing	914 423 211 00	\$2.94	\$2.30	--	--
51 Bell Crank, 914-6	914 423 025 01	\$188.99	--	--	--

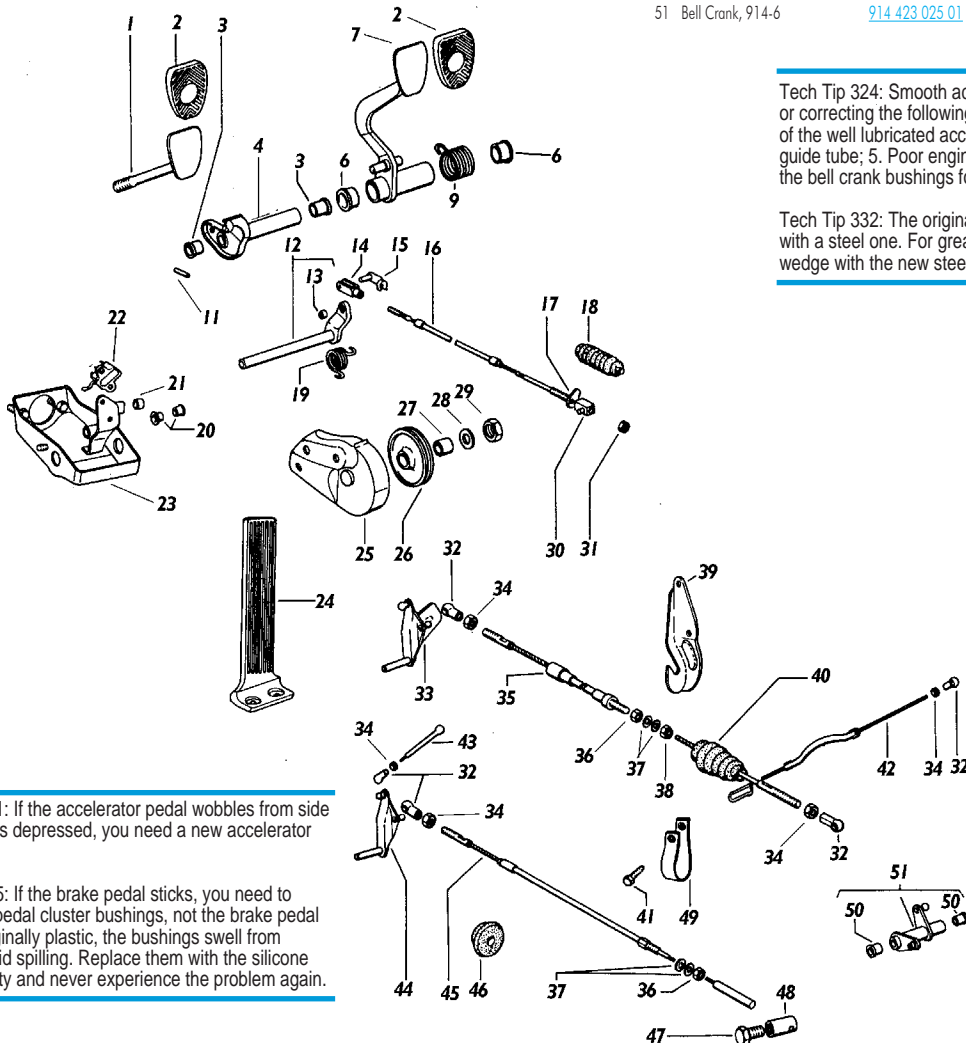

Tech Tip 321: If the accelerator pedal wobbles from side to side as it is depressed, you need a new accelerator pedal.

Tech Tip 335: If the brake pedal sticks, you need to replace the pedal cluster bushings, not the brake pedal springs. Originally plastic, the bushings swell from the brake fluid spilling. Replace them with the silicone bronze variety and never experience the problem again.

Tech Tip 324: Smooth accelerator action can be achieved by checking and/or correcting the following: 1. Accelerator pedal stiffness; 2. Smooth routing of the well lubricated accelerator cable; 3. Throttle body wear; 4. A pinched guide tube; 5. Poor engine grounding; Additionally, on 914-6 models, check the bell crank bushings for wear.

Tech Tip 332: The original plastic clutch cable wedge has been replaced with a steel one. For greater reliability, always replace the original plastic wedge with the new steel one.

914 & 914-6 Pedals & Levers

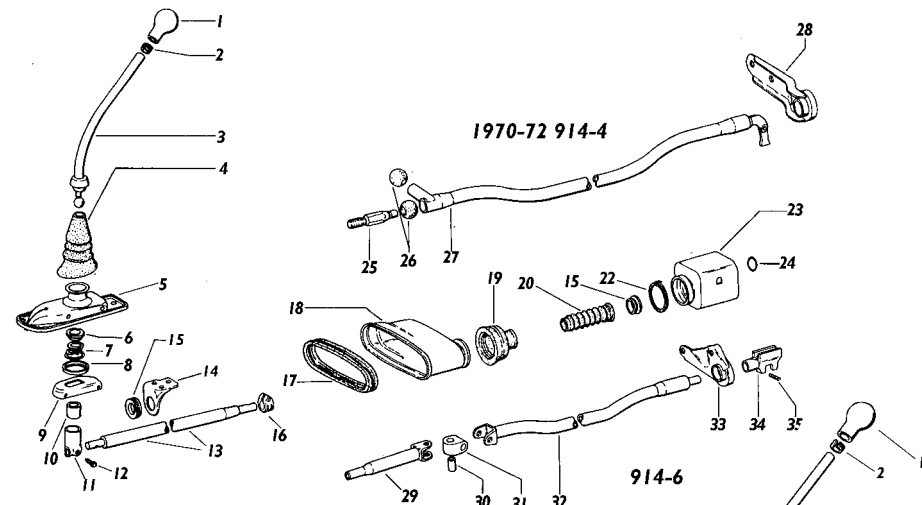

Tech Tip 341: The 70-72 early model shift linkage is of poor design, as the factory tried using 911 shift components while extending the shift an extra four feet. After ten years of use, the shift contact parts wore out, causing extreme slop in the assembly. The solution is to weld the worn contact points and then install an aftermarket short shift kit.

Tech Tip 359: Always make sure the rear 73-76 shift cup bushing is firmly snapped onto the shift lever ball socket and then greased before installing the shift rod head.

Tech Tip 355: Three varieties of shifter pivot bushings were made for Porsches and all will fit the 73-76 914 shifter pivot/universal. However, use only the one with part number 911 424 223 03. The others are slotted and will cause shifter slop. Unfortunately, however, the proper 914 variety is about four times as costly as their inferior brothers. Fortunately, an excellent aftermarket replacement exists.

Tech Tip 356: If oil accumulates in the 73-76 rear plastic shift cover, the shift shaft seal is leaking.

914 & 914-6 Pedals & Levers

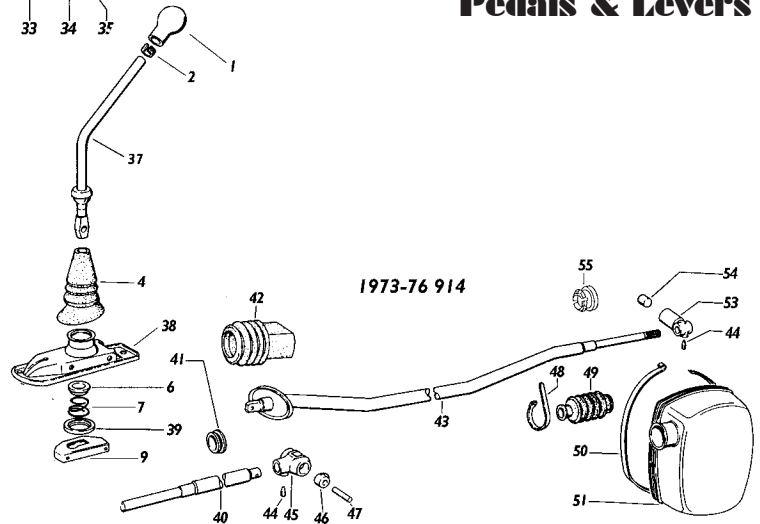

Description	Part Number	Gen.	Repl.	Used	Rep./Reb.
1 Shift Knob	901 424 014 00	\$183.28	--	--	\$74.50
2 Shift Knob Clip	999 532 001 00	\$8.62	--	--	\$4.50
3 Gear Shift Lever	914 424 016 00	\$149.07	--	\$100.00	--
4 Rubber Shift Lever Boot	914 424 901 00	\$56.36	--	\$14.00	--
5 Shift Lever Housing	901 424 015 02	\$305.77	--	\$140.00	--
6 Upper Shift Lever Bushing	901 424 132 00	\$6.84	--	--	--
7 Thrust Spring For Gear Shift Lever	914 424 131 00	\$7.70	--	\$4.00	--
8 Lower Shift Lever Bushing	901 424 135 00	\$6.48	--	--	--
9 Reverse Lock Out Plate	901 424 017 00	\$21.70	--	--	--
10 Front Shift Cup Bushing	911 424 139 00	\$12.17	\$10.39	--	--
11 Shift Socket	930 424 241 00	\$86.58	--	\$40.00	--
12 Cone Screw	901 424 229 00	\$4.43	\$3.30	--	--
13 Gear Shift Rod	914 424 021 00	\$92.69	--	\$50.00	--
14 Bearing Bracket	930 424 031 00	\$32.03	--	\$15.00	--
15 Shifter Bushing (Need 3)	914 424 224 00	\$16.16	\$13.70	--	--
16 Clamp	914 424 214 00	\$10.45	--	\$5.00	--
17 Front Shift Cover Band	914 424 502 00	\$28.26	--	\$11.00	\$19.50
18 Front Shift Cover	Pcg 424 501 00	\$60.63	--	\$30.00	--
19 Front Shift Cover Boot	914 424 297 00	\$35.92	--	--	\$25.00
20 Rear Shift Cover Boot	901 741 291 00	\$18.40	--	--	--
22 Rear Shift Cover Clamp	999 512 348 02	\$3.50	\$2.50	--	--
23 Rear Shift Cover 914-6	914 424 206 00	\$45.20	--	--	--
Rear Shift Cover 914-4	914 424 229 00	\$49.12	--	\$30.00	--
24 Rubber Ring	914 424 208 00	\$5.29	--	--	--
25 Bolt, Hex Hd	914 424 511 00	\$19.05	--	\$10.00	--
26 Shifter Ball Bushing	914 424 512 00	\$12.08	\$10.39	--	--
27 Gear Shift Rod	914 424 032 03	\$287.68	--	\$150.00	--
28 Gear Shift Rod Support	914 424 014 00	\$32.23	--	\$12.00	--
29 Connecting Tube 914-6	914 424 027 00	\$108.58	--	\$56.00	--

Description	Part Number	Gen.	Repl.	Used	Rep./Reb.
30 Bush	914 424 223 00	\$4.67	--	--	--
31 Intermediate Piece 914-6	914 424 212 00	\$12.90	--	--	--
32 Gear Shift Rod, 914-6	914 424 022 00	\$245.80	--	\$150.00	--
33 Gear Shift Rod Support	914 424 012 00	\$23.30	--	--	--
34 Gear Shift Rod Head	914 424 241 00	\$205.70	--	--	--
35 Spiral Pin	999 095 021 00	\$2.50	--	--	--
37 Gear Shift Lever	914 424 016 02	\$168.12	--	\$105.00	--
38 Shift Lever Housing	914 424 019 02	\$58.91	--	\$30.00	--
39 Lower Shift Lever Bushing 2.3mm	914 424 343 01	\$14.86	--	--	--
Lower Shift Lever Bushing 3.4mm	914 424 343 02	\$14.16	--	--	--
40 Gear Shift Rod, Front	914 424 065 00	\$95.08	--	\$65.00	--
41 Firewall Bushing	914 424 224 03	\$13.85	\$11.50	--	--
42 Front Shift Boot	914 424 169 02	\$41.08	--	\$25.00	--
43 Gear Shift Rod, Rear	914 424 063 00	\$256.61	--	\$200.00	--
44 Cone Screw	901 424 229 00	\$4.43	\$3.30	--	--
45 Shift Coupler	911 424 221 00	\$98.53	\$83.52	\$58.00	--
46 Shift Coupler Bushing	911 424 223 03	\$34.62	\$30.00	--	\$16.00
47 Shift Coupling Pin	900 092 002 00	\$5.50	--	--	--
48 Rear Shift Boot Tie	999 513 003 40	\$1.51	\$1.15	--	--
49 Rear Shift Boot	914 424 239 02	\$30.35	--	--	--
50 Rear Shift Cover Band	914 424 503 01	\$11.00	\$2.30	--	--
51 Rear Shift Cover	PCG 424 501 01	\$50.00	--	--	--
53 Rear Shift Coupling	914 424 241 02	\$207.95	--	\$150.00	--
54 Rear Shifter Cup Bushing	911 424 139 00	\$12.17	\$10.39	--	--
55 Rear Crown Bushing	914 424 224 02	\$20.50	\$11.50	--	--

914 HARD PARTS

Tech Tip 361: If the two piece 70-72 emergency brake handle will not disengage, the spring clip on the release rod is broken. This part is available separately.

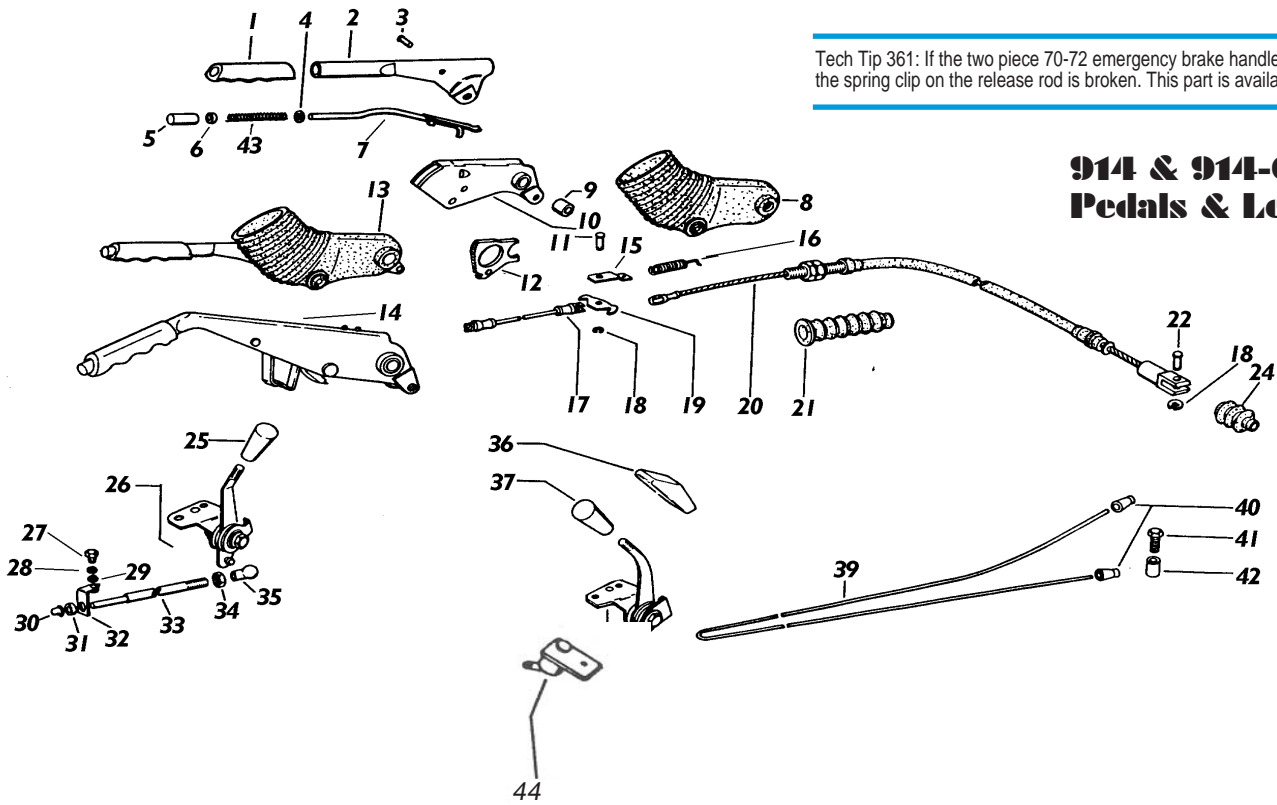

914 & 914-6 Pedals & Levers

Description	Part Number	Gen.	Repl.	Used	Rep./Reb.
1 Handle	901 424 521 01	\$13.51	--	\$8.00	--
2 Hand Brake Lever Frame, 1970-72	914 424 056 00	\$16.79	--	--	--
Hand Brake Lever Frame, 1973-76	914 424 056 02	\$65.08	--	--	--
3 Rivet A 4h 11x16	900 224 013 00	\$1.10	--	--	--
4 Washer	900 089 001 02	\$1.10	--	--	--
5 Em Brake Handle Button	901 424 523 01	\$12.00	--	--	--
6 Ring	901 424 593 01	\$2.74	--	--	--
7 Pressure Rod, 1970-72	914 424 055 00	\$63.76	--	--	--
Pressure Rod, 1973-76	914 424 255 02	\$23.76	--	--	--
8 Rubber Sleeve	914 424 057 00	\$36.02	--	\$25.00	--
9 Em Brake Handle Bushing	914 424 247 00	\$10.38	--	--	--
10 Lever Base	914 424 054 00	\$31.92	--	--	--
11 Em Brake Pin	914 424 571 00	\$4.87	--	--	--
12 Locking Segment	914 424 541 00	\$20.68	--	\$8.50	--
13 Em Brake Handle 1970-72	914 424 053 00	\$218.41	--	\$100.00	--
Em Brake Handle 1973-76	914 424 053 01	\$219.14	--	\$120.00	--
14 Em Brake Handle 1973-76	914 424 053 01	\$219.14	--	\$120.00	--
15 Shackle	914 424 567 00	\$39.47	--	\$15.00	--
16 Equalizer Cable Return Spring	914 424 545 00	\$28.07	--	--	\$9.50
17 Em Brake Equalizer Cable	914 424 256 00	\$92.12	--	\$52.00	--
18 Locking Ring	NO 126 452	\$2.00	--	--	--
19 Compensating Piece	914 424 568 00	\$16.75	--	\$9.00	--
20 Em Brake Cable, Left	914 424 551 01	\$68.44	\$51.97	\$30.00	--
Em Brake Cable, Right	914 424 552 01	\$68.44	\$51.97	--	--
21 Em Brake Front Cable Boot	914 424 592 00	\$16.62	--	--	--
22 Bolt A 6x15x12	NO 234 942	\$4.25	--	--	--
24 Em Brake Rotor Cable Boot	914 424 591 00	\$7.60	--	--	--

Description	Part Number	Gen.	Repl.	Used	Rep./Reb.
25 Handle Knob 914-6	914 424 792 00	\$39.03	--	\$20.00	--
26 Throttle Lever	914 424 071 00	\$173.59	--	\$105.00	--
27 Bolt, Hex Hd M 6x12	999 072 005 09	\$2.09	\$1.15	--	--
28 Washer 6,4	NO 115 247	\$1.00	\$1.00	--	--
29 Spring Ring B6	900 027 014 02	--	\$1.00	--	--
30 Sleeve	914 424 225 00	\$16.00	--	\$9.00	--
31 Sliding Ring	914 424 219 00	\$19.91	--	--	--
32 Support	914 424 024 00	\$32.03	--	--	--
33 Pressure Rod	914 424 035 00	\$88.56	--	--	--
34 Hexagon Nut M5	NO 110 0514	\$1.00	\$1.00	--	--
35 Ball Cup A 8	NO 155 213	\$13.94	--	--	--
36 Heater Knob - 1972 Only	911 424 792 01	\$20.03	--	--	--
37 Heater Knob	914 424 792 01	\$39.03	--	\$20.00	--
38 Heating Control Usa 1972 Only	914 424 073 04	\$57.79	--	--	--
Heating Control 1973-76	914 424 073 02	\$75.22	--	--	--
Heat Control/middle Console 1973-76	914 424 073 02	--	--	\$220.00	--
39 Wire Pull For Heating 914-6	914 424 075 00	\$32.74	--	--	--
Wire Pull For Heating 1970-74 914-4	914 424 075 01	\$39.90	--	--	--
Wire Pull For Heating 1975-76	914 424 075 03	\$32.22	--	--	--
40 Heater Control Cable Boot	113 711 691	\$4.50	--	--	--
41 Bolt, Hex Hd M 5x10	NO 102 056	\$1.00	\$1.15	--	--
42 Pin 1970-72	311 129 177	\$4.84	\$4.04	--	--
Pin 1973-76	311 129 777	\$7.79	\$4.04	--	--
43 Thrust Spring	901 424 543 00	\$9.30	--	\$4.00	--
44 Emergency Brake Switch	968 613 601 00	\$10.89	\$8.70	\$6.00	--

914 & 914-6 Body

Description	Part Number	Gen.	Repl.	Used	Rep./Reb.
1 Plate Above Trans. 1970-74	914 501 083 10	\$2,505.89	--	\$916.00	\$192.00 <small>Floor Only</small>
2 Clamping Strip	914 501 827 10	\$37.56	--	--	--
3 Engine Bay Seal, Rear	914 504 117 10	\$77.20	--	--	\$44.00
4 Engine Bay Seal, Front (Left Or Right)	914 504 155 10	\$48.62	\$36.80	--	--
5 Rt. Rear Suspension Console	914 501 018 10	\$1,170.11	\$675.67	\$485.00	\$192.00
6 Reinforcement, Left	914 501 143 10	\$36.59	--	--	--
Reinforcement, Right	914 501 144 10	\$38.23	--	--	--
7 Connecting Plate, Left	914 501 141 10	\$53.60	--	--	--
Connecting Plate, Right	914 501 142 10	\$53.60	--	--	--
8 Heating Tube, Front Left	914 501 027 10	\$265.16	--	--	--
Heating Tube, Front Right	914 501 028 10	\$220.92	--	--	--
9 Sound Absorber, 1970-76	911 572 025 02	\$252.01	--	--	--
10 Heating Tube, Rear Left	914 501 031 10	\$242.58	--	--	--
Heating Tube, Rear Right	914 501 032 10	\$242.58	--	--	--
11 Longitudinal Member Inner, Left	914 501 435 10	\$3,958.06	--	--	--
Longitud. Member Inner, Right	914 501 436 12	\$3,958.06	--	--	\$650.00
12 Engine Mounting, Left	914 501 183 10	\$414.01	--	\$175.00	--
Engine Mounting, Right	914 501 184 10	\$519.69	--	\$300.00	--
13 Engine Shroud Seal, Lat. L	914 504 155 10	\$48.62	\$36.80	--	--
Engine Shroud Seal, Lat. R	914 504 155 10	\$48.62	\$36.80	--	--
14 C-Channel	914 501 825 10	\$75.72	--	--	\$38.44
15 Connecting Plate	914 501 643 10	\$600.64	--	--	\$250.00 <small>2-Pc. Kit</small>
16 Covering	914 559 163 10	\$59.92	--	\$38.90	--
17 Floor L & R Half	914 501 937 10	\$4,401.67	--	\$450.00	\$400.00
18 Connecting Plate Front Left 1975-76	914 507 011 10	\$206.48	--	--	--
Connecting Plate Front Right 1975-76	914 507 012 10	\$187.05	--	--	--
19 Reinforcing For Axle Suspension	914 501 057 00	\$197.30	--	\$75.00	--
20 Tow Eye, Front	914 501 531 10	\$90.27	--	--	--
Tow Eye, Rear	914 722 105 10	\$40.34	--	--	--
21 Reinforcing For Crosswall, Left, 1973-74	914 502 109 10	\$159.75	--	--	--
Reinforcing For Crosswall, Right, 1973-74	914 502 110 10	\$159.75	--	--	--

Description	Part Number	Gen.	Repl.	Used	Rep./Reb.
22 Connecting Plate, Front, Right, 1970-74	914 501 116 10	\$172.29	--	--	--
Connecting Plate, Front, Left, 1970-74	914 501 115 10	\$172.29	--	--	--
23 Bracket, Left	914 507 041 10	\$158.42	--	--	\$82.00
Bracket, Right	914 507 042 10	\$165.31	--	--	\$82.00
24 Floor Pan Plug	914 559 241 10	\$27.14	--	--	--
26 Floor Front	914 501 937 11	\$4,401.67	--	\$950.00	--
27 Engine Shelf Plug 914-6	914 559 243 10	\$26.52	--	--	\$9.50
28 Crossmember	914 501 109 10	\$892.77	--	--	\$220.00
29 Engine Shelf Plug 914-6 Fuel Line	914 559 245 10	\$2.00	--	--	--
30 Battery Tray	914 501 587 10	\$157.50	--	--	\$55.00
31 Battery Support	914 501 073 10	\$76.99	--	--	\$26.95
32 Battery Clamp Bolt	N0 102 477	\$1.00	\$1.00	--	--
33 Battery Clamp Bolt Washer	900 027 015 02	\$1.00	\$2.00	--	--
34 Battery Clamp	914 611 233 10	\$14.09	\$9.65	--	\$8.20
35 Support For Handbrake	914 501 075 10	\$123.69	--	--	\$65.00
36 C Channel	914 501 825 10	\$75.72	--	--	\$38.44
37 Engine Shelf	914 501 436 12	\$3,958.06	--	--	\$650.00

Tech Tip 373: If the right rear wheel is suddenly radically in at the top and out at the bottom, the rear suspension console has broken and needs replacing. Battery acid is the culprit!

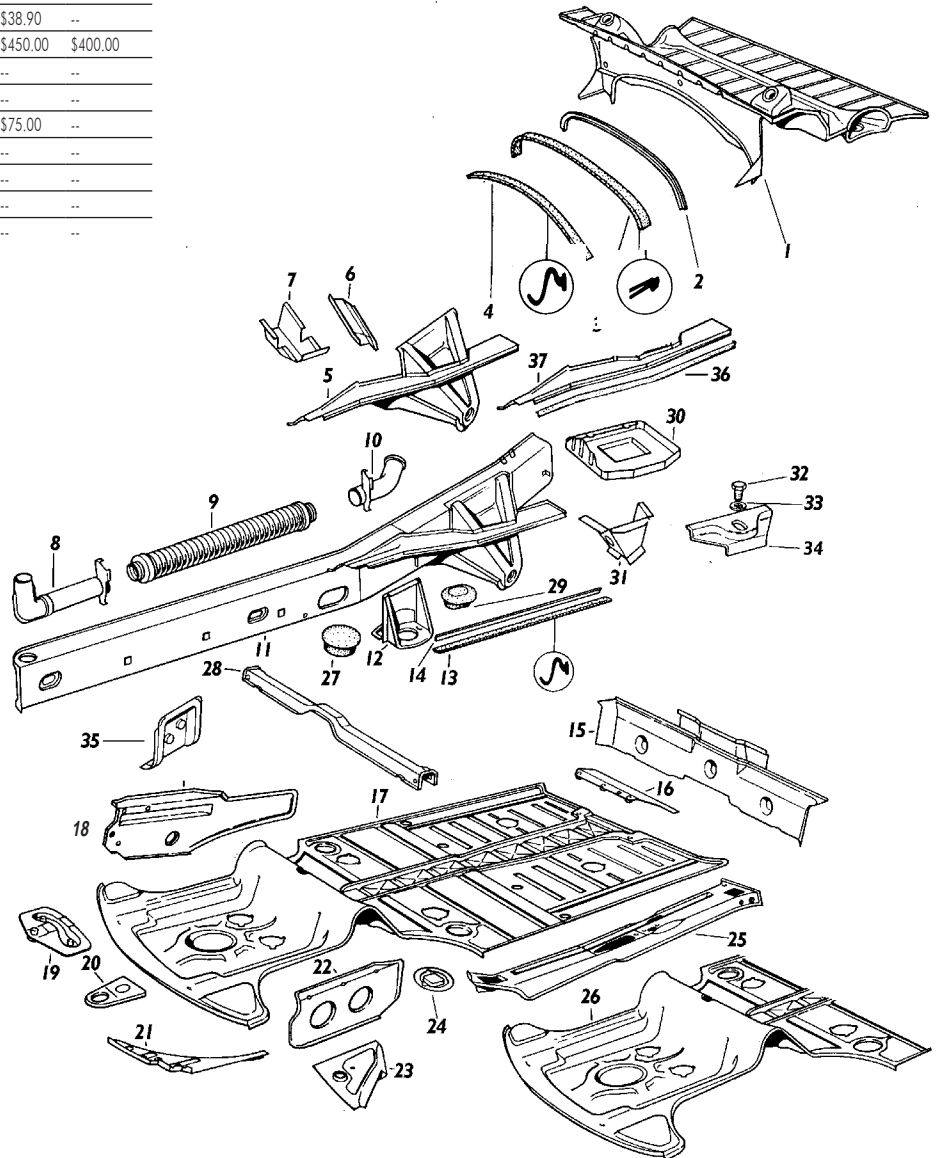

Tech Tip 371: Retrofitting of the 73-76 rear floor pan air flaps helps cool 70-72 model engines.

Tech Tip 372: Always seal and paint the floor pan after installation. Rust conversion paint, seam sealer, chip guard, and factory matched polyurethane paint are necessities in any restoration.

914 HARD PARTS

Description	Part Number	Gen.	Repl.	Used	Rep./Reb.
1 Backwall, Upper Part 1970-71	914 502 011 10	\$791.89	\$739.00	\$581.00	--
Backwall, Upper Part 1972-76	914 502 011 11	\$953.44	\$739.00	\$581.00	--
2 Engine Lid Hinge Bracket	914 502 011 20	--	--	--	\$35.00
3 Clamp Strip	914 501 823 10	\$214.35	--	--	--
4 Guide Tube For Hood Release Cable	914 502 237 10	\$79.63	--	--	--
5 Backwall, Lower Part, 914-6	914 501 007 10	\$1,662.01	--	--	--
Backwall, Lower Part, 914-4 1970-71	914 501 119 10	\$1,353.11	--	--	\$137.00
Backwall, Lower Part, 914-4 1972	914 501 119 11	\$1,353.11	--	--	\$137.00
Backwall, Lower Part, 914-4 1973-74	914 501 119 13	\$1,353.11	--	--	\$137.00
Backwall, Lower Part, 914-4 1975-76	914 501 119 14	\$1,353.11	--	--	\$137.00
6 Wheel Case, Inner Plate Left Rear	914 501 941 10	\$1,808.86	--	--	--
Wheel Case, Inner Plate, Rt Rear 914.4 & 914.6	914 501 944 10	\$1,808.86	--	--	\$192.00 Partial
7 Rear Deck Hinge Pivot	914 501 030 10	\$54.65	--	--	\$24.20
8 Jack Support Plate	914 501 151 10	\$28.14	--	--	\$19.50
9 Jack Support Tube	914 501 153 10	\$51.78	--	--	\$22.00
10 Sill Plate, Left	914 501 089 10	\$416.78	--	--	--
Sill Plate, Right	914 501 090 10	\$352.07	--	--	\$93.00
11 Inner Rocker Panel, Left	914 501 013 10	\$307.32	--	--	\$121.00
Inner Rocker Panel, Right	914 501 014 10	\$305.35	--	--	\$121.00
12 Plastic Rivet	999 591 550 40	\$1.80	--	--	--
13 Tapping Screw B2 4.2x19	900 187 017 02	\$1.00	\$1.00	--	--
14 Washer A4.3	900 025 002 02	\$1.00	--	--	--
15 Distance Washer	914 559 127 10	\$3.00	--	--	\$4.00
16 Tapping Nut	999 507 229 00	\$1.00	\$1.00	--	--
17 Outer Rocker Panel, Left	914 503 125 10	\$419.56	--	--	\$165.00
Outer Rocker Panel, Right	914 503 126 10	\$478.77	--	--	\$165.00
18 Jack Hole Plug	914 559 267 10	\$12.50	\$3.24	--	--

Description	Part Number	Gen.	Repl.	Used	Rep./Reb.
19 Cover For Air Outlet 1972-76	914 555 043 10	\$51.66	--	\$25.00	--
20 Fender W/ Lock Post, Left	914 503 903 11	\$1,701.51	--	\$950.00	--
Fender W/ Lock Post, Right	914 503 904 11	\$1,701.51	--	\$950.00	--
21 Rear Cross Wall 1970-74	914 503 065 11	\$1,071.22	--	\$675.00	--
Rear Cross Wall 1975-76	914 503 065 11	\$1,071.22	--	\$675.00	--
22 Windshield Frame	914 503 057 10	\$1,725.05	--	\$950.00	--
23 Fender Divider	914 559 155 10	\$9.95	--	--	\$2.20
24 Crosswall W/windshield Frame 1970-71	914 503 901 10	\$1,957.47	--	\$1,250.00	--
Crosswall W/windshield Frame 1972-76	914 501 195 10	\$1,957.47	--	\$1,250.00	--
25 Fender Left	914 503 031 11	\$1,981.34	--	\$850.00	--
Fender Right	914 503 062 11	\$1,987.71	--	\$850.00	--
26 Box For Headlight, Left	914 502 041 11	\$225.06	--	\$125.00	--
Box For Headlight, Right	914 502 042 11	\$225.06	--	\$125.00	--
27 Chassis, Front Part 1970-71	914 501 901 10	\$9,517.31	--	\$2,000.00	--
Chassis, Front Part 1972-74	914 501 901 11	\$10,597.25	--	\$2,000.00	--
Chassis, Front Part 1975-76	914 501 901 13	\$8,973.88	--	\$2,000.00	--
28 Front Panel Plug	914 559 252 10	\$19.00	--	\$7.00	--
29 Front Cross Wall 1970-74	914 502 031 12	\$1,592.05	--	\$675.00	--
Front Cross Wall 1975-76	914 502 031 13	\$1,253.33	--	\$675.00	--
30 Wheel Case, Left	914 501 033 10	\$2,316.23	--	--	--
Wheel Case, Right	914 501 034 10	\$2,316.23	--	--	--
31 Sway Bar Mounting Plate	914 501 162 10	\$25.66	--	--	--
32 Headlight Blind, Left	914 503 307 10	\$88.07	--	\$45.00	--
Headlight Blind, Right	914 503 308 10	\$88.07	--	\$45.00	--
33 Headlight Eyebrow Grommet	914 750 197 10	\$4.91	--	--	--
34 Screw, 6x12					
35 Washer	900 025 004 01	\$0.65	--	--	--
36 Toothed Washer	900 114 002 02	\$1.00	--	--	--

* With Fenders

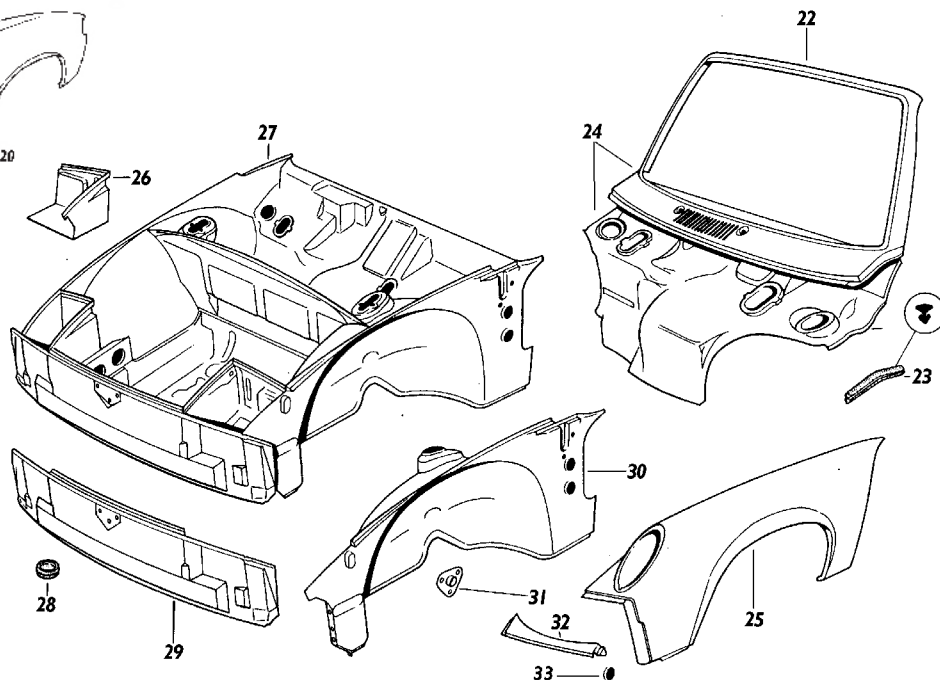
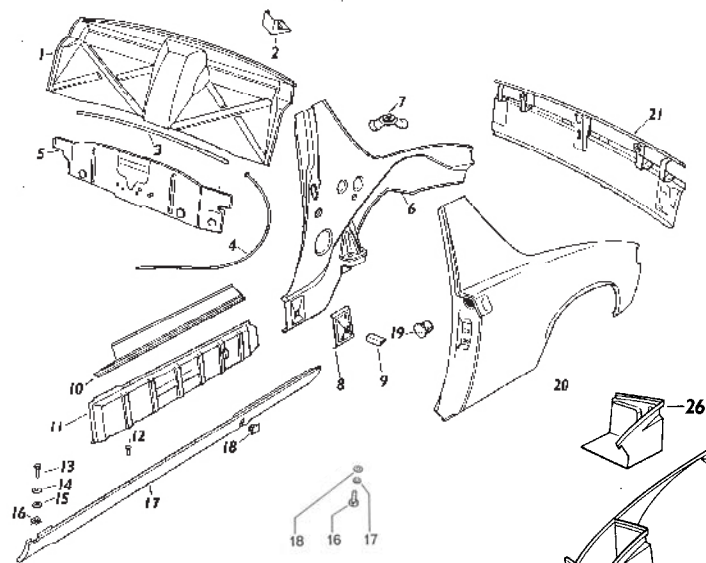

Tech Tip 379: The rear inner wheel house around the jackpost and support is prone to rust, due to the packing of debris under the outer rocker cover. Periodic spraying, using a high pressure water hose, of the area from the rear fender well forward will keep this area clean. If this area rusts, patch panels are available to repair it without removing the complete wheel house.

914 & 914-G Body

Description	Part Number	Gen.	Repl.	Used	Rep./Reb.
1 Shock Absorber, Left	914 505 115 11	\$226.78	--	\$125.00	--
Shock Absorber, Right	914 505 116 11	\$249.12	--	\$125.00	--
2 Spacer Tube	113 807 173	\$3.63	--	--	--
3 Bolt, Hex Hd M12x1.5x55	N0 101 544	\$1.37	--	--	--
4 Support For Bumper	914 505 033 11	\$690.28	--	\$350.00	--
5 Plug	999 703 124 40	\$3.00	--	--	--
6 Foamed Part	914 503 231 12	\$665.53	--	\$400.00	--
7 Bead Above Bumper	914 503 023 10	\$459.36	--	\$225.00	--
8 Bumper, Chromium Plated	914 505 084 10	\$1741.91	--	\$650.00	\$950.00
Bumper, Primed	914 505 083 10	\$1641.91	--	\$450.00	--
9 Bolt, Hex Hd M5x20	N0 102 644	\$1.00	\$1.00	--	--
10 Washer B5.3	900 151 027 02	\$1.00	\$1.15	--	--
11 Spacer	914 559 127 11	\$9.40	--	--	\$4.00
12 Spring Ring B5	N0 120 053	\$1.00	\$1.00	--	--
13 Hexagon Nut M5	N0 110 0514	\$1.00	\$1.00	--	--
14 Tapping Nut	999 507 015 02	\$2.00	\$1.15	--	--
15 Joint	999 151 027 50	\$1.00	\$1.00	--	--
16 Washer	999 151 026 02	\$1.00	\$1.00	--	--
17 Tapping Screw, Hex Hd B4.8x16	900 187 018 02	\$1.00	\$1.00	--	--
18 Bumper Horn, Front Left	914 505 063 10	\$170.00	\$137.00	\$75.00	--
Bumper Horn, Front Right	914 505 064 10	\$170.00	\$144.37	\$75.00	--
19 Front Belly Pan	914 503 121 10	\$699.91	--	\$150.00	\$104.00
20 Spacer	914 559 253 10	\$27.50	--	--	--
21 Front Spoiler	914 503 235 10	\$524.90	--	--	\$98.00
22 Support For License Plate	914 701 119 10	\$41.06	--	--	--

* Rebuilt Parts Require A Rebuildable Core

Tech Tip 406: Front and rear 75-76 bumper shocks are interchangeable right to right and left to left.

Tech Tip 409: The front plastic "special edition" spoiler was a factory option in 1974-1976 and replaced the front steel belly pan.

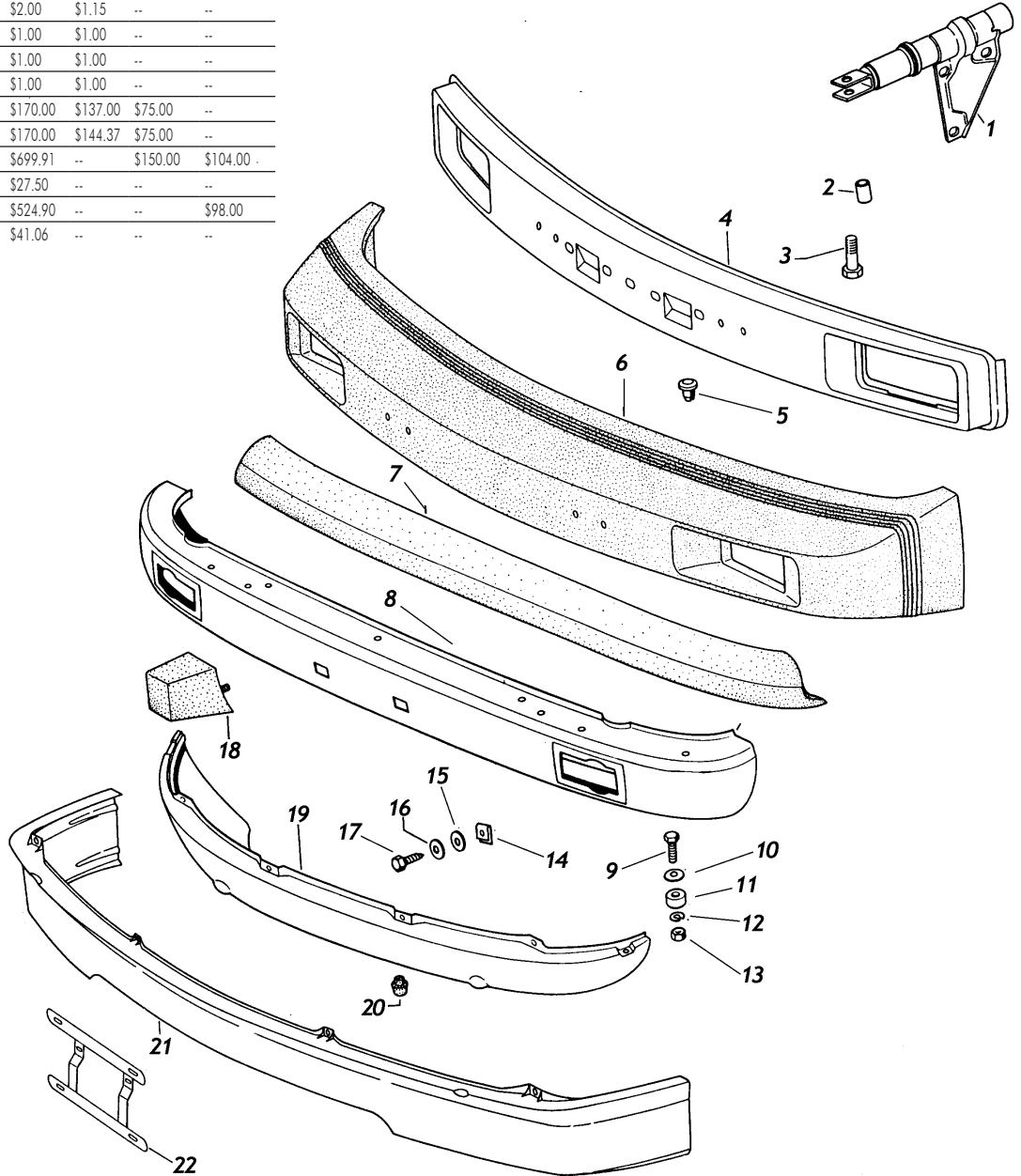

914 HARD PARTS

Description	Part Number	Gen.	Repl.	Used	Rep./Reb.
1 Covering, Rear	914 503 009 10	\$750.00	--	\$200.00	--
2 Hexagon Nut M5	N0 110 0514	\$1.00	\$1.00	--	--
3 Washer 5.3	900 151 027 02	\$2.00	\$1.15	--	--
4 Distance Washer	914 559 127 11	\$9.40	--	--	\$4.00
5 Bolt, Hex Hd M5x20	N0 102 644	\$1.00	\$1.00	--	--
6 Tapping Nut	999 507 015 02	\$2.00	\$1.15	--	--
7 Tapping Screw, Hex Hd B4, 2x13	N0 138 845	\$1.00	\$1.00	--	--
8 Bolt, Hex Hd M 8x40	N0 103 404	\$2.22	\$1.00	--	--
9 Tooth Lock Washer J 8,2	900 114 021 01	\$1.00	\$1.00	--	--
10 Washer B 8,4	900 151 008 02	\$1.00	\$1.00	--	--
11 Base	914 505 027 10	\$12.37	--	\$8.00	--
12 Bumper, Chrome 1970-73	914 505 019 10	\$1,724.47	--	\$570.40	\$950.00*
Bumper, Primed 1970-73	914 505 920 10	\$1,053.91	--	\$450.00	--
Bumper, Chrome Plated USA 1974	914 505 092 10	\$1,140.26	--	\$570.00	\$950.00*
Bumper, Primed USA 1974	914505 091 10	\$925.02	--	\$458.00	--
13 Rear Toe Eyeplug Chrome	914 722 109 10	\$41.55	--	--	\$16.00
Rear Toe Eyeplug Prime	914 722 107 10	\$4.55	--	--	--

Description	Part Number	Gen.	Repl.	Used	Rep./Reb.
14 Hexagon Nut, M8	900 076 025 02	\$2.00	\$1.15	--	--
15 Washer A 8,4	900 025 009 02	\$1.00	\$1.00	--	--
16 Bumper Horn USA Left	914 505 085 10	\$161.93	--	\$100.00	--
Bumper Horn USA Right	914 505 086 10	\$173.23	--	\$100.00	--
17 Base, Rubber Washer	914 559 116 10	\$1.00	\$1.00	--	--
18 Washer A 6,4	900 151 006 02	\$1.19	\$1.15	--	--
19 Hex Nut M6	900076 010 02	\$1.00	\$1.00	--	--
20 Bead Above Bumper	914 503 027 10	\$459.47	\$399.72	\$150.00	--
21 Shock Absorber USA	914 505 116 11	\$249.11	--	\$125.00	--
Shock Absorber USA	914 505 115 11	\$226.78	--	\$125.00	--
22 Support For Bumper USA	914 505 099 10	\$665.28	--	\$350.00	--
23 Bumper Cover	914 503 233 10	\$752.16	--	\$350.00	--
24 Plug For Towing Eye	914 722 107 11	\$6.55	--	--	--
25 Bumper Horn Left	914 505 191 10	\$154.96	--	\$90.00	--
Bumper Horn Right	914 505 192 10	\$156.88	--	\$90.00	--
26 Plastic Rivet	999 591 554 40	\$3.00	--	--	--

*All rebuilt parts require a core exchange.

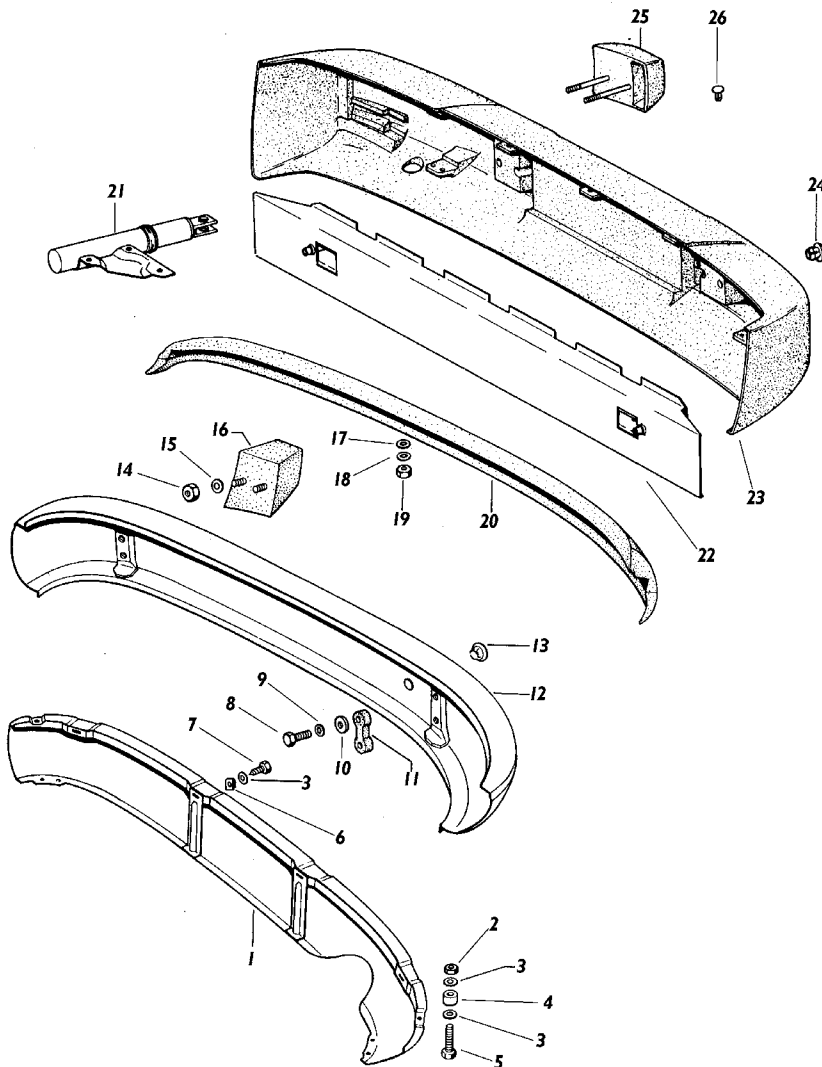

914 & 914-G Body

Tech Tip 406: Front and rear 75-76 bumper shocks are interchangeable right to right and left to left.

Tech Tip 403: Three different rear valances were originally fitted to the 914: 1. Long top to bottom 70-72 914-6 valance with left tail pipe hole; 2. Long 70-72 914-4 valance with left center tail pipe hole; 3. Short 73-76 valance with notch. The two longer valances were discontinued in 1972 because they impeded engine cooling and, in the winter, acted as a snow plow.

We have the original 1970-71 valance with the hole. Call for prices and availability...

914 & 914-6 Body

Description	Part Number	Gen.	Repl.	Used	Rep./Reb.
1 Bulkhead Seal	914 511 902 10	\$77.57	\$80.27	\$42.00	\$30.00
2 Hood (Front Lid)	914 511 001 10	\$1,707.36	--	\$680.00	--
3 Front Hood Seal	914 511 901 10	\$207.65	\$180.75	--	\$59.50
4 Front Trunk Latch, Upper	914 511 051 10	\$93.88	--	\$40.00	--
5 Front Trunk Latch, Lower	914 511 052 10	\$63.83	--	\$40.00	--
6 Hood Cable Release Sheath	914 511 231 10	\$38.96	--	\$35.00	--
7 Hood Cable	914 511 091 10	\$28.01	--	\$15.00	--
8 Handle W/lock Cylinder 2	914 511 907 00	\$160.40	--	\$72.00	--
9 Blank Key	914 531 903 10	\$22.48	\$16.88	--	--
10 Front Hood Hinge, Left	914 511 035 10	\$89.53	--	\$31.00	--
Front Hood Hinge, Right	914 511 036 10	\$89.53	--	\$31.00	--
11 Shoulder Bolt	914 512 191 10	\$17.60	--	\$4.00	\$9.90
12 Rear Trunk Seal Front	914 512 315 10	\$101.59	\$69.00	\$40.00	\$30.00
13 Rear Lid	914 512 001 10	\$816.79	--	\$590.00	--
14 Rear Trunk Seal, Rear	914 512 317 10	\$114.62	\$72.18	\$40.00	\$30.00
15 Rear Trunk Lock	914 512 913 00	\$404.32	--	\$200.00	--
16 Rear Trunk Lock Seal	914 512 193 10	\$15.46	--	--	\$8.80
17 Rear Trunk Lid Latch, Upper	914 512 041 10	\$55.27	--	\$40.00	--

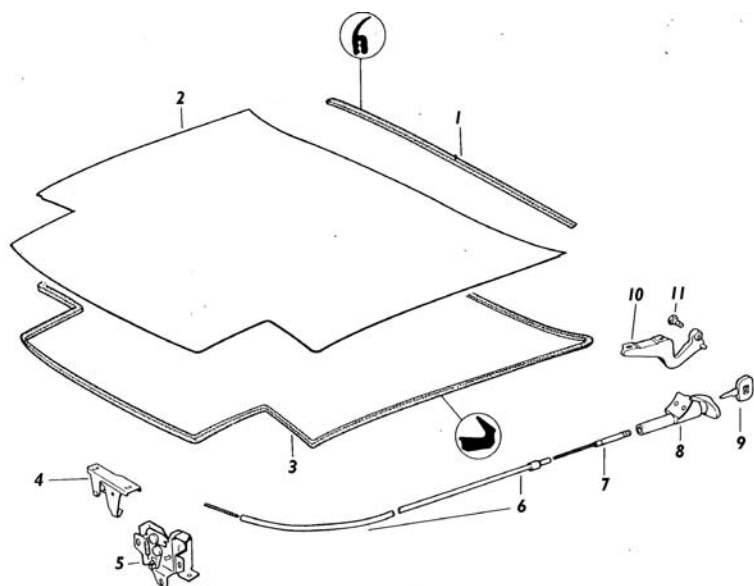

Description	Part Number	Gen.	Repl.	Used	Rep./Reb.
18 Rear Trunk Lid Latch, Lower	914 512 042 10	\$59.40	--	\$31.00	--
19 Rubber Buffer	999 703 036 50	\$3.00	\$3.00	\$2.00	--
20 Rear Lid Torsion Bar Spring, Left	914 512 227 10	\$193.29	--	\$45.00	--
Rear Lid Torsion Bar Spring, Right	914 512 228 10	\$215.90	--	\$45.00	--
21 Rear Lid Torsion Bar Clamp	914 512 219 10	\$4.39	--	\$2.50	--
22 Shoulder Bolt	914 512 191 10	\$17.60	--	\$4.00	\$9.00
23 Trunk Hinge Roller, Large 1970-74	PVP 512 263 10	\$13.35	--	--	--
Trunk Hinge Roller, Small 1975-76	914 512 263 11	\$11.24	--	--	--
24 Rear Hood Hinge, Left 1975-76	914 512 059 10	\$84.23	--	\$35.00	--
Rear Hood Hinge, Right 1975-76	914 512 060 10	\$84.54	--	\$35.00	--
25 Top Latch Cup	914 559 227 10	\$19.80	--	\$9.00	--
26 Front Top Holder	914 559 219 10	\$16.92	--	\$8.00	--
27 Rear Top Holder, Left	914 559 015 10	\$22.94	--	\$11.00	--
Rear Top Holder, Right	914 559 016 10	\$22.94	--	\$11.00	--
28 Rear Lid Hinge Support Strap	914 512 215 10	\$24.50	--	\$15.00	--
29 Trunk Hinge Cup	914 501 030 10	\$54.65	--	--	\$24.20
30 Trunk Hinge Bolt	914 512 191 10	\$17.60	--	\$4.00	\$9.90

Tech Tip 428: If the front corner of the rear decklid suddenly seems high on one side, you have broken the trunk hinge bracket.

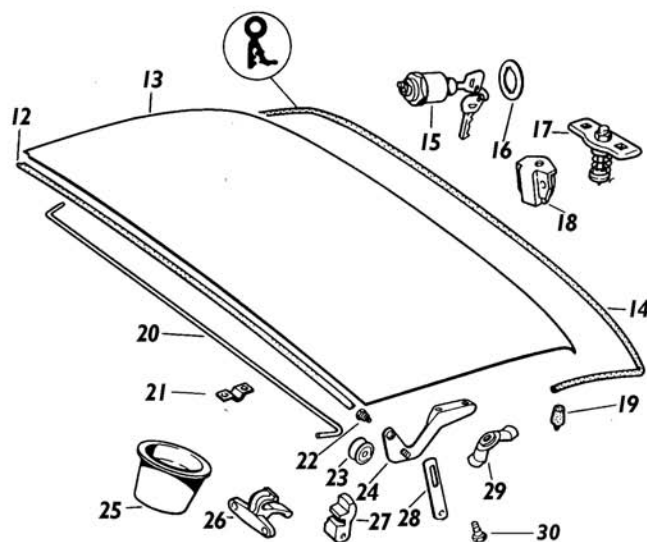

Tech Tip 430: If the rear trunk acts locked even when unlocked, you need a replacement trunk cam because yours is broken.

Tech Tip 412: When replacing the hood seal, it is advisable not to glue it, as a seal secured in this manner holds water and will rust out the gutter. Rather, periodically remove the seal and clean the gutter area, touching up any rust areas. Even the most rust-free cars seem to develop rust in the headlight box gutter!

Tech Tip 426: If you notice rust bubbles on the rear edge of the rear trunk lid, it is body rust caused by moisture-soaked sound deadening foam that was factory injected in the lid reinforcement cavities. Water leaking into the trunk, coupled with power plant heat, caused water vapor to be absorbed. The wet foam laying against the metal subsequently rusted the lid. Repair is very time consuming and tedious. Unfortunately, because of this expense, the best solution is to stop the trunk leaks as soon as they start!

914 HARD PARTS

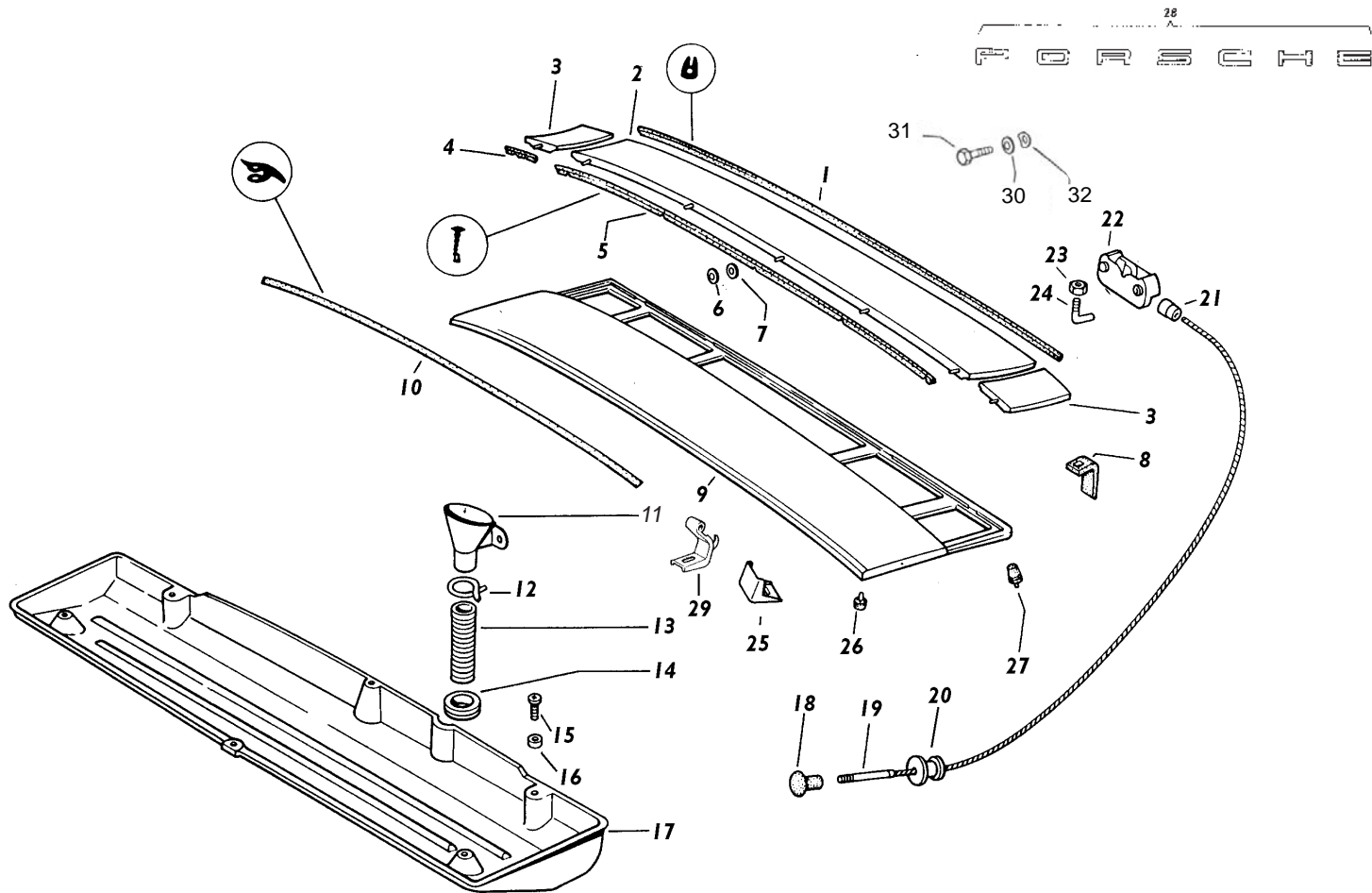

Description	Part Number	Gen.	Repl.	Used	Rep./Reb.
1 Rear Grille Edging	914 504 111 10	\$24.33	\$16.10	\$10.00	--
2 Grill, Engine Lid	914 504 013 10	\$267.08	--	\$135.00	--
3 Engine Lid Grille Extension, Left	914 504 011 10	\$67.73	--	\$35.00	--
Engine Lid Grille Extension, Right	914 504 012 10	\$67.73	--	\$35.00	--
4 Grill To Body Seal, Left	914 504 107 10	\$7.58	--	--	--
Grill To Body Seal, Right	914 504 108 10	\$5.59	--	--	--
5 Grille To Lid Welting	914 504 105 10	\$41.00	--	--	\$13.20
6 Engine Grill Clip	999 507 220 40	\$2.16	--	--	--
7 Washer	999 025 060 40	\$1.00	--	--	--
8 Rubber Stop	914 512 195 10	\$39.50	--	\$15.85	--
9 Engine Lid	914 512 022 10	\$427.83	--	\$195.00	--
10 Rear Lid To Glass Seal	914 512 319 10	\$71.99	--	\$59.00	\$39.00
11 Engine Lid Funnel	914 559 231 10	\$25.20	--	\$15.00	--
12 Hose Clamp	999 512 165 02	\$6.00	--	\$4.00	--
13 Water Drain Hose	914 559 129 10	\$30.86	--	\$15.00	--
14 Rubber Sleeve	999 702 091 50	\$17.88	--	\$10.00	--
15 Lens Head Screw Am6x20	900 146 002 02	--	\$1.00	--	--
16 Distance Bushing For Water Drip Cup	914 512 182 10	\$4.00	--	--	--
17 Engine Lid Drip Pan	914 512 189 10	\$295.24	--	\$95.00	\$125.00

Description	Part Number	Gen.	Repl.	Used	Rep./Reb.
18 Handle	901 552 813 20	\$14.71	--	\$6.00	--
19 Engine Release Cable	914 512 091 10	\$28.01	--	\$15.00	--
20 Retaining Bushing	914 512 177 10	\$14.33	--	\$10.00	--
21 Sealing Sleeve	914 504 319 00	\$4.69	--	--	--
22 Engine Lid Lock	914 512 029 10	\$59.04	--	\$35.00	--
23 Hexagon Nut Ms	900 076 025 02	\$2.00	\$1.15	--	--
24 Latch Catch	914 512 155 10	\$4.51	--	--	--
25 Engine Lid Hinge Bracket	914 502 011 10	--	--	--	\$35.00
26 Engine Lid Spring Buffers	914 559 253 10	\$29.50	--	--	--
27 Hood Stop	311 823 499 A	\$3.00	\$3.00	\$2.00	--
28 "Porsche" Letters Chrome 1973-76	PNA 559 901 00	--	--	\$65.00	\$65.00
"Porsche" Letters Gold 1970-72	901 559 301 22	\$79.50	--	\$60.00	--
29 Deck Lid Hinge Left	914 512 139 10	\$25.03	--	--	--
Deck Lid Hinge Right	914 512 140 10	\$25.04	--	--	--
30 Latch Washer	900 151 003 02	\$1.00	--	--	--
31 Latch Bolt	900 074 015 02	\$1.00	--	--	--
32 Latch Lock Washer	900 028 003 01	--	\$1.00	--	--

*Recad Plated

**chromed Steel

All Rebuilt Parts Require A Rebuildable Core

Tech Tip 420: Always make sure the four cylinder engine lid drip pan is installed and in good condition. This part funnels water away from the engine compartment, easing wet start-up and prolonging accessory life.

Tech Tip 417: If the rear engine lid fits poorly and rubs the front of the rear decklid, no matter how much it is adjusted, the firewall hinge bracket is fatigued. Although never available separately through the factory, an excellent reinforced reproduction is available.

Part No. 29: We have seen these bend before, after a hard rear end impact and then the lid will not adjust.

914 & 914-6 Body

914 & 914-6 Body

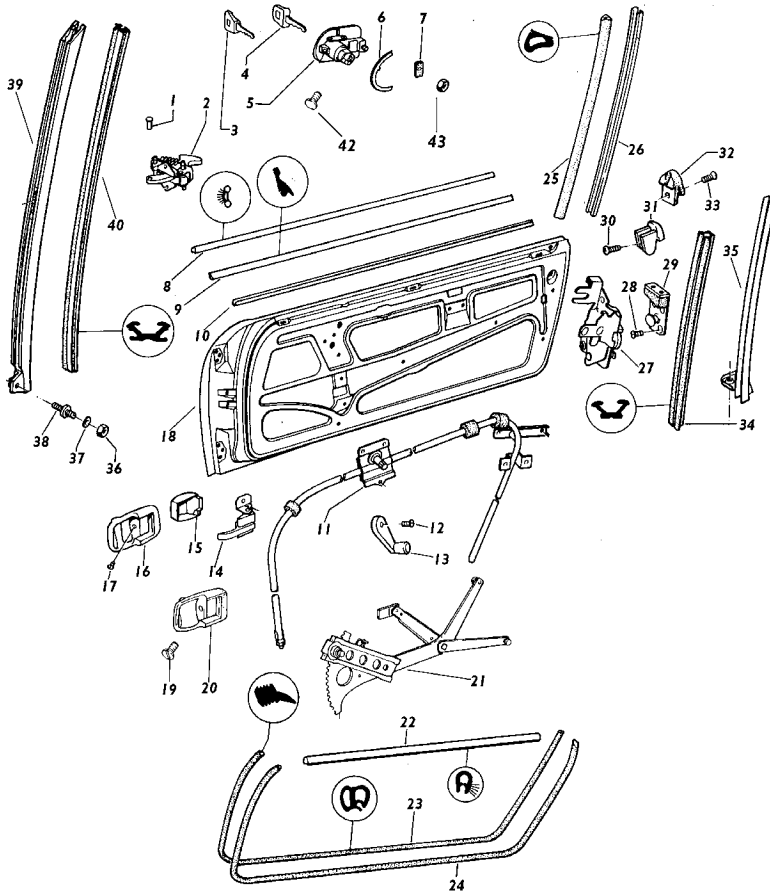

Tech Tip 440: Always reinstall the plastic vapor barrier under the door panel after completing any window or mechanism repair. This will help keep moisture from warping the door panel or seeping into the interior.

Tech Tip 442: A worn door strap will prevent the door from holding itself open. A broken one will allow the door to open too far, damaging itself and the front fender.

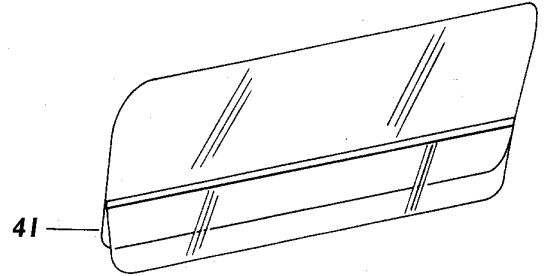

Note: early 1973 models with a 4732900... serial number use the 1970-72 style window regulator assembly.

Description	Part Number	Gen.	Repl.	Used	Rep./Reb.
1 Door Strap Pin	900 088 014 02	\$4.40	--	\$3.00	--
2 Door Strap	914 531 037 10	\$203.88	--	\$100.00	\$98.94*
3 Blank Key (Red)	914 531 903 11	\$13.80	\$13.80	--	--
4 Blank Key (Blk)	914 531 903 10	\$16.88	\$16.88	--	--
5 L. Outer Door Lock W/2 Keys (No Lock #)	914 531 905 00	\$237.92	\$185.95	\$95.00	\$99.00 Kit
R. Outer Door Lock W/2 Keys (No Lock #)	914 531 906 00	\$237.92	\$185.95	\$95.00	\$99.00 Kit
6 Large Door Handle Seal	PVP 531 601 10	\$27.83	--	--	\$3.00
7 Small Door Handle Seal	914 531 603 10	\$49.05	--	--	\$3.00
8 Outer Fuzzy Strip	914 531 957 10	\$69.97	--	--	--
9 Left Squeegee	914 531 873 10	\$15.83	\$9.82	--	\$6.50
Right Squeegee	914 531 874 10	\$15.73	\$9.82	--	\$6.50
10 Squeegee Gusset, Left/Right 1970-72	914 531 951 10	\$67.50	--	\$47.00	--
Squeegee Gusset, Left 1973-76	914 531 959 10	\$69.23	--	\$47.00	--
Squeegee Gusset, Right 1973-76	914 531 958 10	\$69.22	--	\$47.00	--
11 Window Regulator, Left 1970-72	914 542 041 10	\$356.50	--	\$195.00	--
Window Regulator, Right 1970-72	914 542 042 10	\$372.74	--	\$150.00	--
12 Countersunk Screw	N0 142 633	\$1.00	\$1.00	--	--
13 Window Crank 1970-72	113 837 581 D	\$47.84	\$32.00	\$20.00	--
Window Crank 1973-74	113 837 581 J	--	\$9.24	\$6.00	--
Window Crank 1975-76	321 837 581	--	\$9.24	\$6.00	--
14 Inner Door Latch, Left	411 837 071	\$198.88	--	\$95.00	--
Inner Door Latch, Right	411 837 072	\$196.05	--	\$95.00	--
15 Handle Cup	411 837 095	\$25.00	--	\$15.00	--
16 Door Latch Surround 1970-72	411 837 097	\$20.61	--	\$15.00	--
17 Countersunk Screw 1970-72	900 147 004 02	\$1.00	\$1.00	--	--
18 1970-72 Door Shell, Left	914 531 005 12	\$2,696.32	--	\$550.00	--
1970-72 Door Shell, Right	914 531 006 12	\$2,696.32	--	\$550.00	--
1973-76 Door Shell, Left	914 531 167 10	\$2,696.32	--	\$550.00	--
1973-76 Door Shell, Right	914 531 168 10	\$2,696.32	--	\$550.00	--
19 Lens Head Screw 1973-76	N0 141 274	\$1.00	\$1.00	--	--
20 Door Latch Cup 1973-76	211 837 097	\$17.83	--	\$10.00	--
21 Window Regulator, L 1973-76	914 542 043 10	\$262.29	--	\$95.00	--
Window Regulator, R, 1973-76	914 542 044 10	\$271.89	--	\$75.00	--
22 Inner Fuzzy Strip	914 531 939 10	\$24.52	\$17.32	--	--

Description	Part Number	Gen.	Repl.	Used	Rep./Reb.
23 Door Frame Seal, Left	914 531 821 10	\$87.05	\$68.14	\$40.00	\$30.20
Door Frame Seal, Right	914 531 822 10	\$87.05	\$68.14	\$40.00	\$30.20
24 Door Seal, Left (On Door)	914 531 813 10	\$133.73	\$98.17	\$25.00	\$38.50
Door Seal, Right (On Door)	914 531 814 10	\$133.73	\$98.17	\$25.00	\$38.50
25 Roll Bar Sealing, Left 1970-76	914 531 143 10	\$105.59	\$82.77	--	\$38.50
Roll Bar Sealing, Right 1970-76	914 531 144 10	\$105.93	\$82.50	--	\$38.50
26 Vertical Roll Bar Gusset, Left	914 531 827 10	\$34.19	--	\$20.00	--
Vertical Roll Bar Gusset, Right	914 531 828 10	\$34.19	--	\$20.00	--
27 Door Lock, Left 1970-76	914 531 053 11	\$151.02	--	\$75.00	--
Door Lock, Left, 1970-71	914 531 053 10	\$151.02	--	\$75.00	--
Door Lock, Right 1970-71	914 531 054 10	\$151.02	--	\$75.00	--
Door Lock, Right 1972-76	914 531 054 11	\$151.02	--	\$75.00	--
28 Countersunk Screw	914 531 523 10	\$2.23	\$1.75	--	--
29 Door Striker, Left 1970-76	151 837 035 C	\$32.55	--	\$10.00	--
Door Striker, Right 1970-76	151 837 036 C	\$31.12	--	\$10.00	--
30 Screw 4.2x13	900 144 014 02	\$2.00	\$1.15	--	--
31 Rear Window Cap, Left 1970-72	914 542 111 10	\$42.00	--	\$27.00	\$29.50
Rear Window Cap, Right 1970-72	914 542 112 10	\$42.00	--	\$27.00	\$29.50
32 Rear Window Cap, Left 1973-76	914 542 173 10	\$29.50	--	\$19.50	\$23.50
Rear Window Cap, Right, 1973-76	914 542 174 10	\$29.23	--	\$15.00	\$23.50
33 Tapping Screw	900 140 032 02	\$2.00	\$1.15	--	--
34 Front Window Channel, Rear	914 542 171 14	\$37.39	\$29.64	\$10.00	--
35 Guide Rail	914 542 030 12	\$23.52	--	\$10.00	--
36 Hexagon Nut	900 075 087 02	\$1.00	\$1.00	--	--
37 Washer	900 025 007 02	\$1.00	\$1.00	--	--
38 Assembling Screw	914 542 109 10	\$21.40	--	\$9.50	--
39 1970-72 Channel, Glass Guide Front, L.	914 542 013 10	\$188.58	--	\$75.00	--
1970-72 Channel, Glass Guide Front, R.	914 542 014 10	\$170.00	--	\$75.00	--
1973-76 Channel, Glass Guide Front, L.	914 542 013 11	\$181.19	--	\$93.50	--
1973-76 Channel, Glass Guide Front, R.	914 542 014 11	\$192.19	--	\$100.00	--
40 Front Window Channel, Guide Bar	914 542 161 12	\$46.03	\$28.60	\$12.00	--
41 Vapor Barrier, Left	914 531 033 10	\$10.99	--	--	--
Vapor Barrier, Right	914 531 034 10	\$10.53	--	--	--
42 Door Latch Bolt	914 531 905 D	--	\$2.00	--	\$7.10
43 Nut	900 084 024 02	\$1.00	--	--	--

914 HARD PARTS

Description	Part Number	Gen.	Repl.	Used	Rep./Reb.
1 Qtr Glass, Left, Clear Or Tinted	914 542 023 10	\$102.53	--	\$58.00	--
Qtr Glass, Right, Clear Or Tinted	914 542 024 10	\$108.49	--	\$58.00	--
2 Vent Window Cap	PCG 542 017 10	\$85.11	--	\$50.00	--
3 Countersunk Screw Am 4x8	NO 331 651	\$1.00	--	--	--
5 Door Glass, Left, Clear	914 542 905 10	\$496.94	--	\$195.00	--
Door Glass, Right, Clear	914 542 906 10	\$409.26	--	\$150.00	--
Door Glass, Left, Tinted	914 542 911 10	\$466.99	--	\$225.00	--
Door Glass, Right, Tinted	914 542 912 10	\$477.77	--	\$175.00	--
6 Door Glass Roller	914 542 307 10	\$5.81	--	--	--
7 Spring Washer	914 542 217 10	\$8.60	--	--	--
8 Windshield, Clear	914 541 101 10	\$366.91	\$295.00	--	--
Windshield, Tinted	914 541 102 10	\$415.70	\$286.00	--	--
9 Windshield Chrome, Left	914 541 213 10	\$83.84	--	\$40.00	--
Windshield Chrome, Right	914 541 214 10	\$85.86	--	\$40.00	--
10 Windshield Chrome, Lower	914 541 215 10	\$77.96	--	\$40.00	--
11 Corner Clip	914 541 217 10	\$11.62	--	\$6.00	--
12 Center Clip	914 541 219 10	\$11.92	--	--	--
13 Distance Spacer For W/S	914 541 907 10	\$2.00	--	--	--
14 Rear Window Glass, Clear	914 545 103 10	\$436.17	--	\$50.00	--
Rear Window Glass, Clear, Heated	914 545 101 10	\$436.17	--	\$250.00	--
15 Distance Spacer For W/S	914 541 907 10	\$2.00	--	--	--
16 Windshield Strip Clip	914 541 921 11	\$1.54	--	--	--
17 Glass Seal, Left	914 542 325 10	\$119.39	--	\$47.00	--
Glass Seal, Right	914 542 326 10	\$110.39	--	\$47.00	--
18 Door Glass, Clear, Right, 1973-76	914 542 040 12	\$424.01	--	--	--
Door Glass, Clear, Left, 1973-76	914 542 039 12	\$424.01	--	--	--
Door Glass, Tinted, Left, 1973-76	914 542 035 12	\$710.83	--	--	--
Door Glass, Tinted, Right, 1973-76	914 542 036 12	\$704.15	--	--	--
19 Adhesive Plate for Mirror Base	901 731 133 20	\$4.10	\$4.60	--	--

Tech Tip 460: If the rear window seems loose or rattles, it needs to be resealed with 1/4 inch butyl tape kit. 3M makes an excellent product of this type. Resealing entails removal of the seats, backpad, and seat belt bolsters. A loose rear window can cause water leaks and floor pan rust-out.

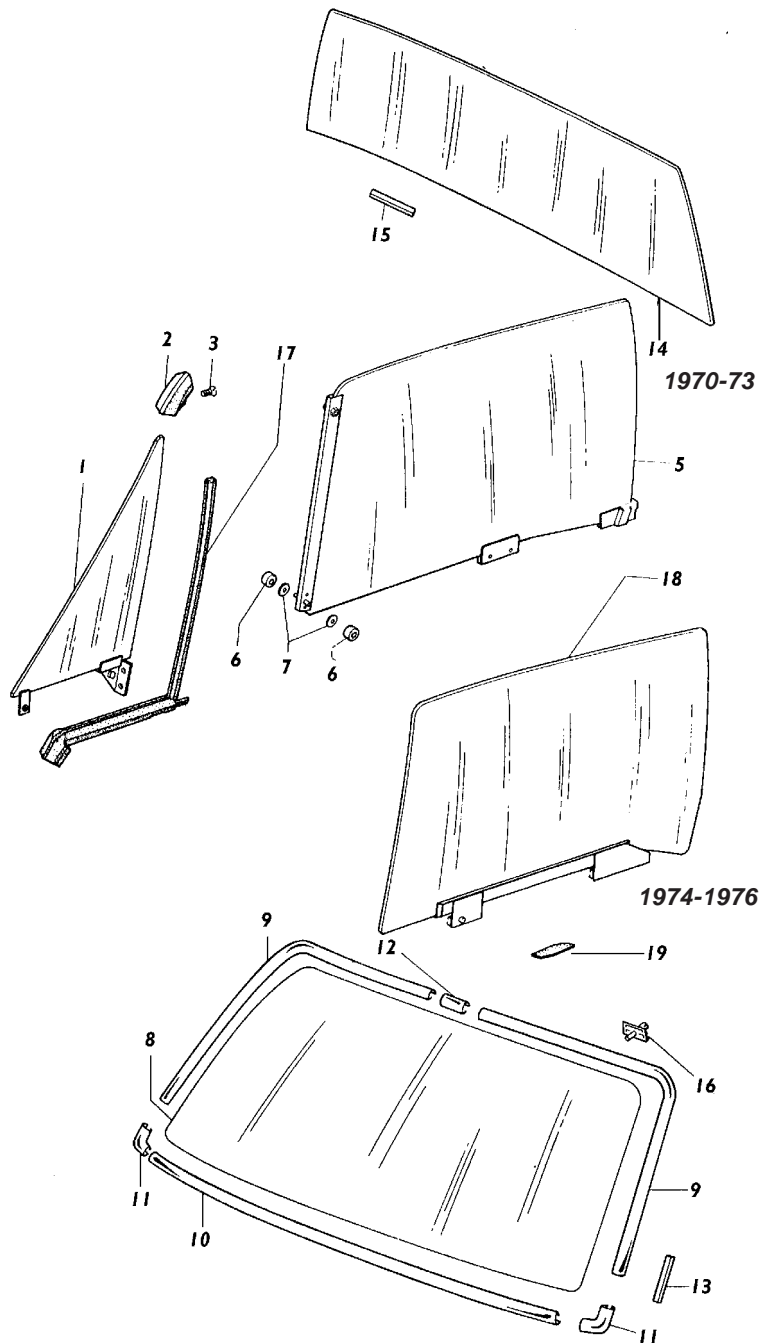

Tech Tip 462: If replacing the front windshield, always replace the 19 plastic windshield clips. If not replaced, the chrome will not attach tightly and may blow off!

Parts that are replacement, used or reproduction are not approved, guaranteed, or warranted by Porsche; use of unapproved parts may negate the factory warranty, or alter safety, emission, aerodynamics, or fuel consumption characteristics.

914 & 914-6 Body

Description	Part Number	Gen.	Repl.	Used	Rep./Reb.
1 Door Panel, Left, 1970 (State Color)	914 555 017 09	\$360.58	--	--	--
Door Panel, Right, 1970 (State Color)	914 555 018 09	\$323.07	--	--	\$192.00
Door Panel, Left, 1971 (State Color)	914 555 017 10	\$360.58	--	\$182.00	\$192.00
Door Panel, Right, 1971 (State Color)	914 555 018 10	\$358.76	--	\$182.00	\$192.00
Door Panel, Left, Early 1972 (State Color)	914 555 017 11	\$358.76	--	\$182.00	\$192.00
Door Panel, Right, Early 1972 (State Color)	914 555 018 11	\$360.58	--	\$182.00	\$192.00
Door Panel, Left, 1972-74 (State Color)	914 555 283 10	\$360.58	--	--	\$192.00
Door Panel, Right, 1972-74 (State Color)	914 555 284 10	\$360.58	--	--	\$192.00
Door Panel, Left, 1975-76 (State Color)	914 555 283 11	\$350.90	--	\$182.00	\$192.00
Door Panel, Right, 1975-76 (State Color)	914 555 284 11	\$360.58	--	\$182.00	\$192.00
2 Plug, Large Interior	914 555 129 10	\$6.00	--	--	--
3 Cheesehead Screw M 5x18	900 067 111 02	\$2.00	\$1.15	--	--
4 Washer	900 025 003 02	\$1.00	\$1.00	--	--
5 Clip (Nut), Barrel Nut	999 507 317 02	\$11.00	\$9.81	\$4.00	--
6 Door Panel Clips To End 1973, White	999 591 310 40	\$1.50	\$1.15	--	--
Door Panel Clips 1974-76, Black	823 867 299	\$2.00	\$1.15	--	\$1.00
7 Fastening Clip Bushing Thru 1973	999 591 311 40	\$4.36	\$1.15	--	--
8 Door Arm Rest	914 555 087 10	\$212.92	--	\$85.00	\$130.00
9 Door Arm Rest Covering, 1970	914 555 044 09	\$111.32	--	\$50.00	--
Door Arm Rest Covering, 1971	914 555 044 10	\$111.32	--	\$50.00	--
Door Arm Rest Covering, 1972-76 (Plastic)	914 555 138 10	\$65.63	--	--	--
10 Rear Roll Bar Pad, 914	914 552 097 12	\$806.99	--	\$295.00	\$450.00
11 Roll Bar Bolster, Left 914	914 552 033 12	\$135.52	--	\$35.00	--
Roll Bar Bolster, Right 914	914 552 034 12	\$138.00	--	\$35.00	--
12 Interior Small Plug	914 552 233 10	\$3.60	--	\$2.00	--
13 Back Pad, Leatherette, 1970-71	914 555 061 09	\$1,996.50	--	\$800.00	\$137.00
14 Back Pad, Leatherette, From 1972-76	914 555 061 12	\$1,981.98	--	\$800.00	\$137.00
15 Rear Trunk Carpet 1970-71	914 551 040 10	\$150.29	--	\$125.00	\$95.00
Rear Trunk Carpet 1972-74	914 551 040 11	\$150.29	--	\$125.00	\$95.00
16 Map Pocket	914 555 021 10	\$571.12	--	\$182.00	\$150.00
17 Map Pocket Frame	914 555 025 10	\$88.19	--	\$25.50	--
18 Map Pocket Cover	914 555 027 10	\$166.77	--	\$85.00	--
19 Back Rest, 1970-71	914 555 081 09	\$339.40	--	--	\$82.50
20 Seat Cushion, 1970, Right	914 521 075 09	\$296.00	--	\$75.00	\$82.00
Seat Cushion, 1971, Right	914 521 075 10	\$296.00	--	\$75.00	\$82.00
21 Center Cushion	914 521 053 09	\$226.87	--	\$75.00	\$43.40
22 Center Tray	914 521 251 10	\$63.55	--	\$25.00	--
23 Washer	999 591 011 12	\$1.00	--	--	--
24 Tapping Screw Rsd.hd B3.9x13	900 145 023 02	\$1.00	\$1.00	--	--
25 Deposit & Back Seat	914 521 556 12	\$499.27	--	\$200.00	\$38.00
26 Center Console	914 559 402 10	\$482.62	--	--	\$235.00
27 Tapping Screw B3.9x19 For Armrest	900 145 022 02	\$2.00	\$1.15	--	--
28 Washer	999 591 011 12	\$1.00	--	--	--
29 Lens Head Sheet Metal Screw B3.9x19	900 143 029 02	\$1.00	\$1.00	--	--
30 Washer 4.3	900 151 028 02	\$1.00	\$1.04	--	--
31 Nut	999 507 401 40	\$2.00	\$1.15	--	--
32 Deposit, Carpet	914 559 037 10	\$417.45	--	\$175.00	--
33 Bracket For Deposit	914 559 035 10	\$37.78	--	\$10.00	--
34 Washer 6.4	900 151 006 02	\$1.19	\$1.15	--	--
35 Lense Head Screw Am 6x15	900 146 001 02	--	\$1.00	--	--
36 Cushion, Left, 1970-76	914 521 035 09	\$417.45	--	\$150.00	\$82.00
37 Interior Light Housing	111 947 111E	\$39.50	\$10.90	--	--
38 Interior Light Bulb	900 631 106 90	\$3.89	\$1.20	--	\$1.00
39 Backpad Screw 5x25	914 555 061 00	--	\$1.50	--	--
40 Backpad Spacer	914 555 061 01	--	--	\$2.00	--
37 Seat, L, 1970, Specify	914 521 010 09	\$1,552.48	--	\$450.00	--
Seat, L, 1971, Specify	914 521 010 10	\$1,622.61	--	\$450.00	--
Seat, L, 1972-74	914 521 010 12	\$1,516.13	--	\$450.00	--
Seat, L, 1975-76	914 521 010 15	\$1,622.61	--	\$450.00	--
Seat, R, 1972-74, Specify	914 521 061 12	\$1,622.61	--	\$450.00	--
Seat, R, 1975-76, Specify	914 521 061 14	\$1,622.61	--	\$450.00	--
38 Seat Rail, Left	914 521 030 10	\$54.96	--	\$40.00	\$16.50
Seat Rail, Right	914 521 029 10	\$95.00	--	\$40.00	\$16.50
39 Seat Frame W/o Catch	914 521 041 10	\$111.60	--	\$50.00	--
Seat Frame, Left, W/height Adj. 1972-74	914 521 031 11	\$294.02	--	\$50.00	--
Seat Frame, Right, W/height Adj. 1972-73	914 521 074 10	\$199.44	--	\$50.00	--
Seat Frame, Left, W/height Adj. 1974-76	914 521 074 11	\$329.27	--	\$50.00	--
40 Seat Adjust Handle, Tilt	914 521 249 10	\$17.16	--	\$10.00	--

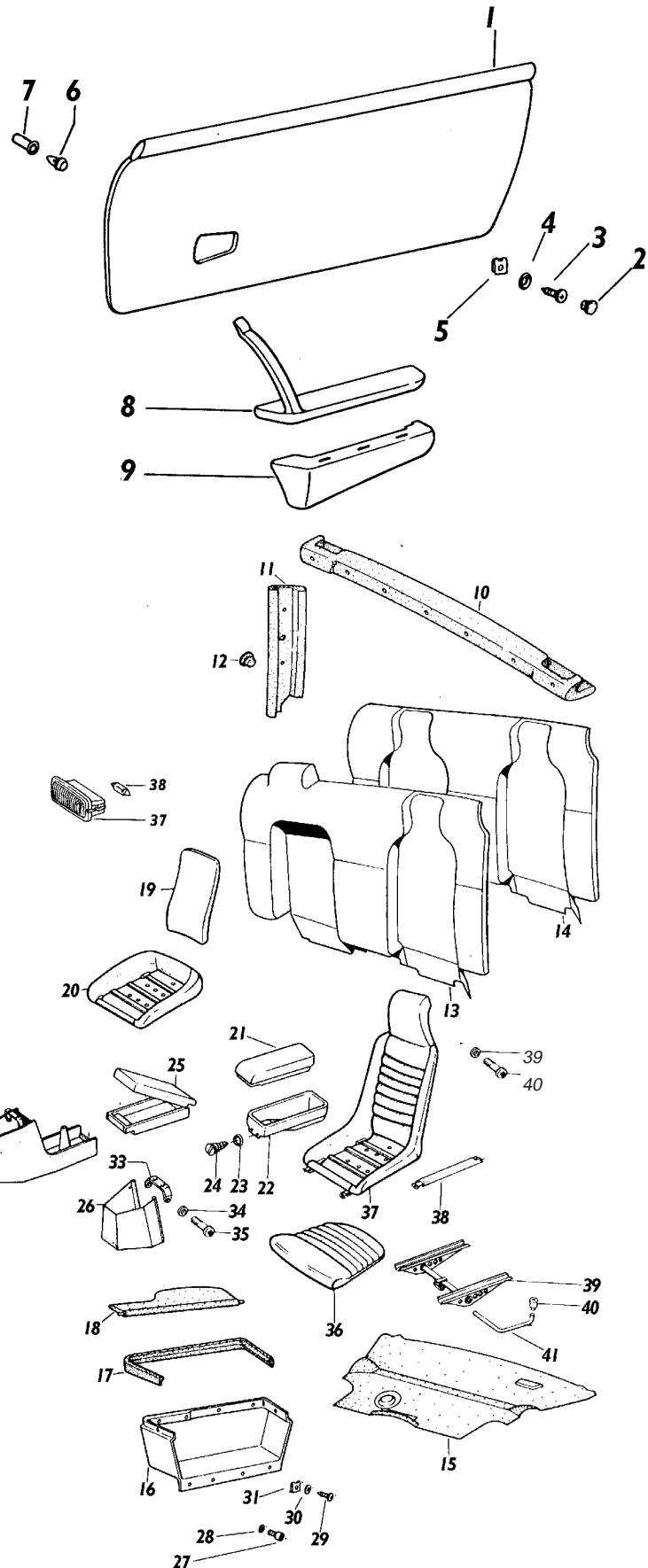

914 HARD PARTS

Description	Part Number	Gen.	Repl.	Used	Rep./Reb.
1 Front Lt Carpet, Felt	914 551 023 10	\$250.00	--	--	--
Front Lt Carpet, Loop	914 551 077 10	\$275.00	--	--	--
2 Front Rt Carpet, Felt, to 72	914 551 024 10	\$250.00	--	--	--
Front Rt Carpet, Felt, 72-Up	914 551 094 10	\$250.00	--	--	--
Front Rt Carpet, Loop, 914-6 (914.4 1970-71)	914 551 078 10	\$250.00	--	--	--
3 Rear Left Carpet, Felt, (State Color)	914 551 021 10	\$166.98	--	--	--
Rear Left Carpet, Loop, (State Color)	914 551 079 10	\$180.90	--	--	--
4 Rear Right Carpet, Felt, (State Color)	914 551 022 10	\$167.58	--	--	--
Rear Right Carpet, Loop, (State Color)	914 551 080 10	\$180.90	--	--	--
5 Lining For Crosswall, Felt, Ft. Left, Felt	914 551 425 10	\$147.62	--	--	--
Lining For Crosswall, Loop,	914 551 081 10	\$167.58	--	--	--
6 Lining For Crosswall, Felt, Front Right	914 551 426 10	\$205.88	--	--	--
Lining For Crosswall, Loop,	914 551 082 10	\$200.43	--	--	--
7 Lining For Crosswall, Felt, Front Left	914 551 149 10	\$57.48	--	--	--
Lining For Crosswall, Loop,	914 551 085 10	\$105.97	--	--	--
8 Lining Crossmember, Left Leatherette 1972-71	914 551 171 11	\$44.14	--	--	--
Lining Crossmember, Left Leatherette 1972-74	914 551 171 11	\$44.14	--	--	--
9 Lining Crossmember, Rt Leatherette 1970-71	914 551 172 10	\$48.76	--	--	--
Lining Crossmember, Left Leatherette 1972-74	914 551 172 11	\$44.14	--	--	--
10 Lining Longitudinal Member, Left, Felt, 914-6/914.4 1970-71	914 551 177 10	\$292.39	--	--	--
Lining Longitudinal Member, Left, Loop	914 551 083 10	\$282.10	--	--	--
Lining Longitudinal Member, Right	914 551 178 10	\$292.39	--	--	--
Lining Longitudinal Member, Right, Loop, 914-6/914.4 1970-71	914 551 084 11	\$271.82	--	--	--
11 Lining For Tunnel, Felt, (State Color)	914 551 179 10	\$282.71	--	--	--
Lining For Tunnel Loop	914 551 076 10	\$220.22	--	--	--
12 Support For Loudspeaker, Left	914 551 505 10	\$209.48	--	--	\$120.00
Support For Loudspeaker, Right	914 551 506 10	\$196.55	--	--	\$120.00
13 Tapping Screw, Csk, Raised Head B4.8x22	900 145 053 07	\$2.00	\$1.00	--	--
14 Tapping Screw, Csk, Raised Head B4.8x16	N0 140 986	\$2.00	\$1.16	--	--
15 Tapping Screw 3.5x16, Chrome, 1970-73	900 145 041 00	\$1.00	\$1.00	--	--
Tapping Screw 3.5x16, Black, 1974-76	900 145 063 02	\$1.00	\$1.00	--	--
16 Pedal Board	914 551 061 10	\$96.00	--	\$65.00	\$47.30
17 Foot Step	914 551 137 11	\$45.62	--	\$19.50	--
Foot Step, Brushed Aluminum	914 551 137 10	--	--	--	\$45.62
18 Alum. Covering For Foot Step Inner	914 551 419 10	\$68.97	--	\$30.00	--
Plastic Covering Foot Step Inner	914 551 419 11	\$68.97	--	\$30.00	--
19 Triangular Pedal Board Clamp	901 501 390 00	\$7.97	--	\$4.00	--
20 Round Pedal Board Clamp	914 551 651 10	\$9.00	--	\$4.00	--
21 Cheesehead Screw M6x15	900 067 009 02	\$3.26	\$1.00	--	--
22 Rivet For Foot Step	999 591 550 40	\$1.50	--	--	--
23 Lining For Crosswall, Felt	914 551 187 11	\$47.67	--	--	\$25.00
Lining For Crosswall, Felt, 1975-76	914 551 107 10	\$83.92	--	--	--
24 Front Tire Board	914 551 029 12	\$212.17	--	\$67.00	\$90.00
25 Foot Rest, Felt, 1970-71	914 551 015 10	\$188.76	--	\$79.00	--
26 Lens Head Tapping Screw B3.5x95	N0 139 575	\$2.00	--	--	--
27 Interior Plug (Spec. Color)	914 552 233 10	\$3.60	--	\$2.00	--
28 Padding For Windshield, Lateral, L, 914	914 555 013 12	\$86.21	--	\$25.00	--
Padding For Windshield, Lateral, R, 914	914 555 014 12	\$86.21	--	\$25.00	--
29 Padding For Windshield, Upper, 914	914 555 047 12	\$589.80	--	\$350.00	--

Tech Tip 488: White plastic rivets attached the 70-early 73 aluminum threshold plate to the rocker sill while black plastic rivets attached the late 73-76 black plastic threshold plates.

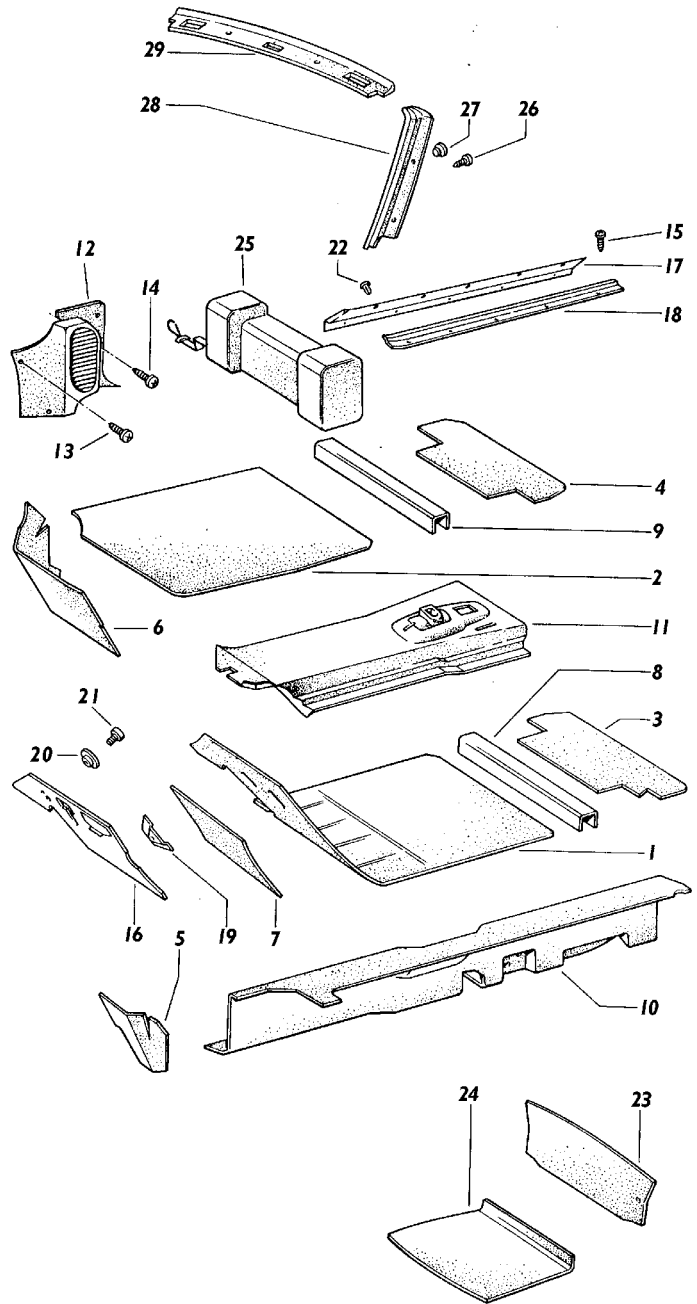

Tech Tip 489: Vinyl trim on the floor pan framing was eliminated in 76-76 and the members were simply painted black.

914 & 914-6 Body

Look at our great factory-match carpet kits on page 103

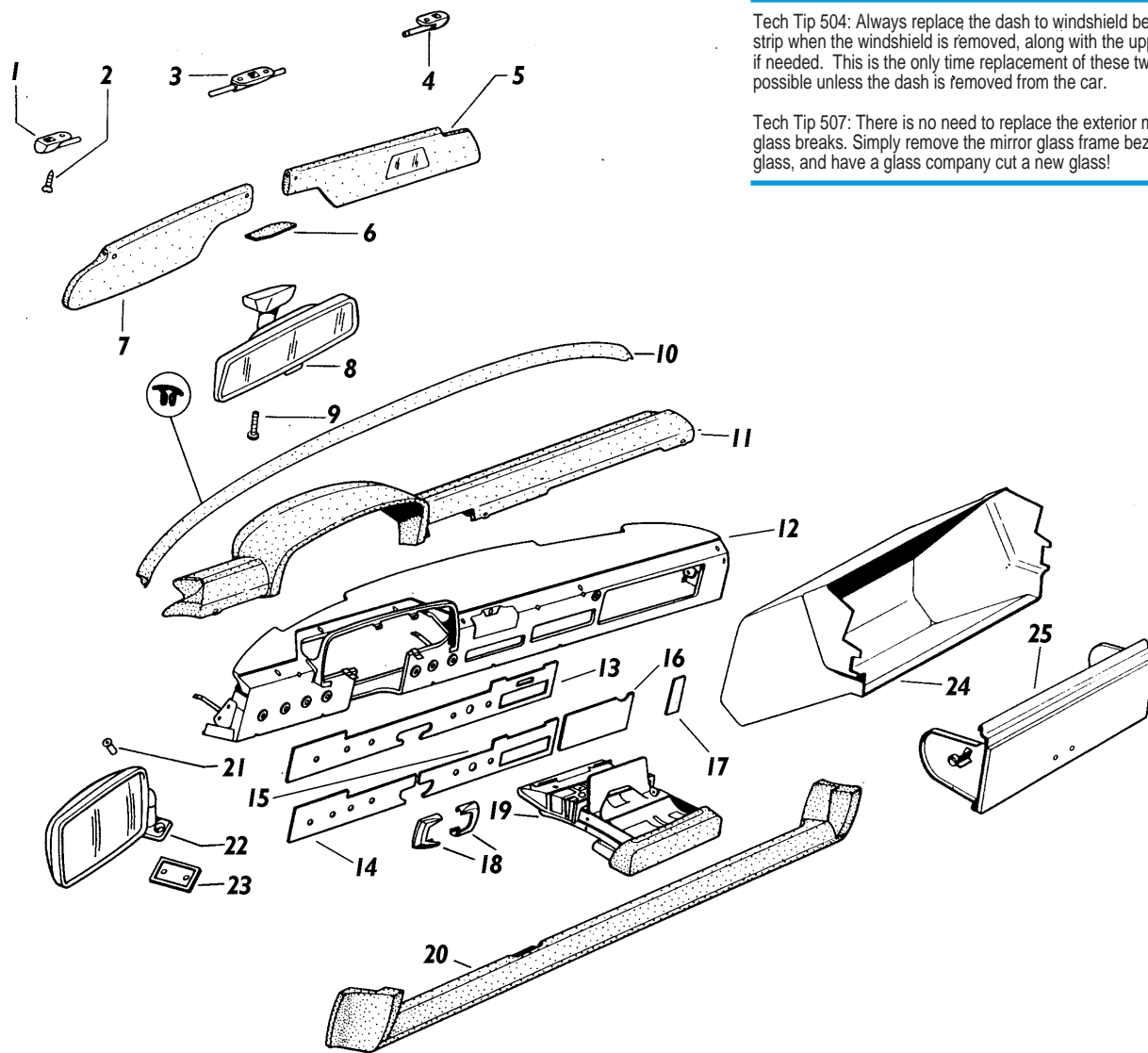

Tech Tip 504: Always replace the dash to windshield bead rubber strip when the windshield is removed, along with the upper dash vinyl if needed. This is the only time replacement of these two items is possible unless the dash is removed from the car.

Tech Tip 507: There is no need to replace the exterior mirror if the glass breaks. Simply remove the mirror glass frame bezel, remove the glass, and have a glass company cut a new glass!

Description	Part Number	Gen.	Repl.	Used	Rep./Reb.
1 Left Outer Visor Pivot	964 731 319 40	\$69.34	--	\$25.00	\$19.50
2 Lens Head Tapping Screw B4, 2x13 1970	N0 140 933	\$2.84	\$1.16	--	--
3 Center Visor Mount	914 731 327 10	\$34.91	--	\$15.00	\$19.50
4 Right Outer Visor Pivot	964 731 320 40	\$67.45	--	\$25.00	\$19.50
5 Sun Visor, Right 914	914 731 044 12	\$343.21	--	\$150.00	--
6 Adhesive Plate For Mirror Base	901 731 133 20	\$6.00	\$4.82	--	--
7 Sun Visor, Left 914	914 731 043 12	\$387.21	--	\$190.00	--
8 Rear View Mirror Inner 1970-71	914 731 014 10	--	--	\$95.00	--
Rear View Mirror Inner 1972-76	914 731 014 11	\$187.72	--	\$95.00	\$75.00
9 Cheese Head Screw Am2, 6x15	900 014 098 10	\$9.46	--	\$5.50	--
10 Dash To W/S Bead	914 552 263 10	\$115.00	--	--	\$39.50
11 Padded Instrument Panel Up To 1971	914 552 031 12	\$947.22	--	\$450.00	\$499.00
Padded Instrument Panel 1972-76	914 552 031 12	\$947.22	--	\$450.00	\$499.00
12 Supporting Plate Instr. Panel 914-6 1970-71	914 552 021 10	\$947.22	--	\$475.00	--
Supporting Plate Instr. Panel 1971	914 552 022 10	\$547.22	--	\$275.00	--
Supporting Plate Instr. Panel 1972-76	914 552 022 11	\$490.15	--	\$275.00	--
13 Covering To Chassis 1975-76	914 552 111 11	\$152.32	--	--	--
14 Covering Up To 1970-71 914-6	914 552 063 10	\$134.10	--	\$25.00	--
Covering 1972-74	914 552 035 10	\$159.90	--	\$15.00	--
15 Covering Center Up To 1971	914 552 043 10	\$183.59	--	\$25.00	--
Covering Center 1972-74	914 552 045 10	\$160.85	--	\$15.00	--

Description	Part Number	Gen.	Repl.	Used	Rep./Reb.
16 Covering Center Radio Up To 1971	914 552 039 10	\$60.70	--	\$22.00	--
Covering Center Radio To Chassis 4752900010	914 552 040 10	\$68.53	\$27.50	--	--
Covering Center Radio 1972-76	914 552 040 10	\$68.53	\$27.50	--	--
Covering Center Radio	914 552 049 10	\$60.77	--	\$22.00	--
17 Covering 1970-71 914-6	914 552 093 10	\$34.28	--	\$15.00	--
18 Covering 1970-71 914-6	914 552 241 10	--	--	\$100.00	\$19.50
19 Ashtray, Comp.	914 552 075 10	--	--	\$35.00	--
20 Knee Guard Covering Up To 1971	914 552 041 10	\$896.93	--	\$385.00	--
Knee Guard Covering From 1972	914 552 041 11	\$845.95	--	\$282.00	--
Knee Guard Covering 1975-76	914 552 041 12	\$845.95	--	\$282.00	--
21 Lens Head Screw Self Locking Am 6x12-4.8	914 531 523 10	\$2.23	--	\$1.75	--
22 Rear View Mirror Outer Up To 1971	914 731 039 10	\$197.35	--	\$95.00	--
Rear View Mirror Outer From 1972	914 731 039 10	\$197.35	--	\$95.00	--
Rear View Mirror (Convex) Outer	914 731 040 10	\$199.50	--	\$95.00	--
23 Base For Outer Mirror	914 731 116 10	\$11.00	\$4.95	--	--
24 Glove Box 1970-71	914 552 501 10	\$250.16	--	--	--
Glove Box 1972-76	914 552 501 11	\$261.73	--	\$76.00	--
25 Glove Box Lid 1970-71	914 552 051 10	\$120.00	--	--	--
Glove Box Lid 1972-76	914 552 051 11	\$84.00	--	\$55.00	--

* All Rebuilt Parts Require A Rebuildable Core

914 HARD PARTS

Description	Part Number	Gen.	Repl.	Used	Rep./Reb.
1 Roll Bar Seal, Left	914 531 143 10	\$105.59	\$82.78	--	\$38.50
Roll Bar Seal, Right	914 531 144 10	\$105.93	\$82.50	--	\$38.50
2 Oval Tapping Screw	900 144 009 00	\$1.00	\$1.00	--	--
3 Vertical Roll Bar Gusset, Left	914 531 827 10	\$34.19	--	\$20.00	--
Vertical Roll Bar Gusset, Right	914 531 828 10	\$34.19	--	\$20.00	--
4 Roll Bar Chrome Clips (3 req'd)	914 559 223 10	\$9.38	--	\$3.00	--
5 Roll Bar Cover	914 559 263 10	\$84.71	--	--	\$30.00
6 Roll Bar Trim Moulding, Left	914 559 017 10	\$22.56	--	\$10.00	--
Roll Bar Trim Moulding, Right	914 559 018 10	\$22.56	--	\$10.00	--
7 Lens Head Tapping Screw	900 143 057 00	\$1.00	\$1.00	--	--
8 Roll Bar Trim Panel, Left	914 559 265 10	\$86.23	--	--	\$38.50
Roll Bar Trim Panel, Right	914 559 266 10	\$86.23	--	--	\$38.50
9 Roll Bar Clip	999 591 326 02	\$2.75	--	--	--
10 Panel Cover Moulding	PCG 559 103 10	\$166.47	--	\$95.00	--
11 Lens Head Tapping Screw	900 145 050 02	\$3.11	\$1.16	--	--
12 Lens Head Tapping Screw	900 145 050 00	\$3.11	\$1.00	--	--
13 Roll Bar Trim Moulding, Rear Left	914 559 101 10	\$177.07	--	\$75.00	--
Roll Bar Trim Moulding, Rear Right	914 559 102 10	\$177.07	--	\$75.00	--
Roll Bar Trim Moulding, Primed Left	914 559 107 10	\$127.91	--	--	--
Roll Bar Trim Moulding, Primed Right	914 559 108 10	\$127.91	--	--	--
14 Distance Piece	914 559 225 10	\$6.00	--	\$4.00	\$2.00
15 Roll Bar Chrome Clip	914 559 011 10	\$14.96	--	\$10.00	\$7.50
16 Roll Bar Trim Moulding, Left Lower	914 559 109 10	\$22.39	--	\$15.00	--
Roll Bar Trim Moulding, Right Lower	914 559 110 10	\$22.39	--	\$15.00	--
17 Horn Grille, Chrome, Left	914 559 257 10	\$102.40	--	\$48.00	--
Horn Grille, Chrome, Right	914 559 258 10	\$102.40	--	\$48.00	--
Horn Grille, Primed, Left	914 559 259 10	\$47.82	--	--	--
Horn Grille, Primed, Right	914 559 260 10	\$47.82	--	--	--
18 Sheet Metal Nut	N 900 488 01	\$1.00	\$1.10	--	--
19 Lens Head Tapping Screw	900 143 033 02	\$1.00	\$1.00	--	--
20 Driving Light Grill, Chrome, Left	914 559 235 10	\$138.61	--	\$68.00	--
Driving Light Grill, Chrome, Right	914 559 236 10	\$138.61	--	\$68.00	--
Driving Light Grill, Primed, Left	914 559 237 10	\$55.09	--	\$25.00	--
Driving Light Grill, Primed, Right	914 559 238 10	\$57.69	--	\$25.00	--
21 Insignia, 914-6	914 559 114 10	\$68.83	--	\$40.00	--
22 Insignia, 1.7, 1973 Only	914 559 115 10	\$93.45	--	\$50.00	--
23 Speed Nut	999 591 423 03	\$2.29	\$1.10	--	--
24 Insignia, 1.8	914 559 459 10	\$28.70	--	\$17.50	--
25 Insignia, 914, Black Plastic 1973-76	914 559 287 11	\$30.30	--	\$20.00	--
Insignia, 914, Gold 1970-72	914 559 113 10	\$75.00	--	\$35.00	--
26 Insignia, 2.0	914 559 120 11	\$26.50	--	\$9.00	--
27 Insignia, Porsche, Gold	901 559 301 22	\$78.30	--	\$40.00	--
Insignia, Porsche, Chrome	PNA 559 901 00	--	\$65.00	\$65.00	--
28 Speed Nut	999 591 423 03	\$2.29	\$1.10	--	--
29 Insignia, 914-6 VW Porsche Gold	914 559 112 10	\$145.00	--	--	--
30 Insignia, 914 VW Porsche, Gold	914 559 111 10	\$77.57	--	--	--
Insignia, 914 VW Porsche, Black	914 559 289 10	\$61.02	--	--	--

*Steel

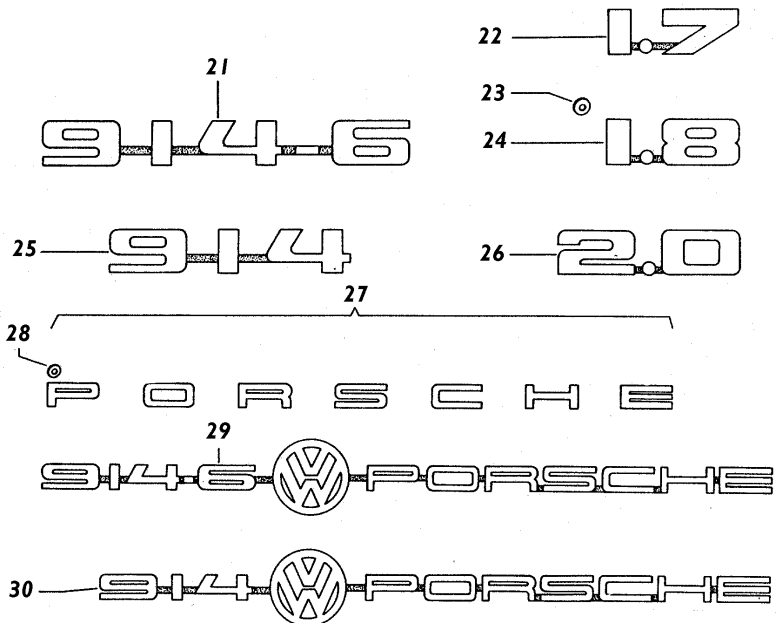
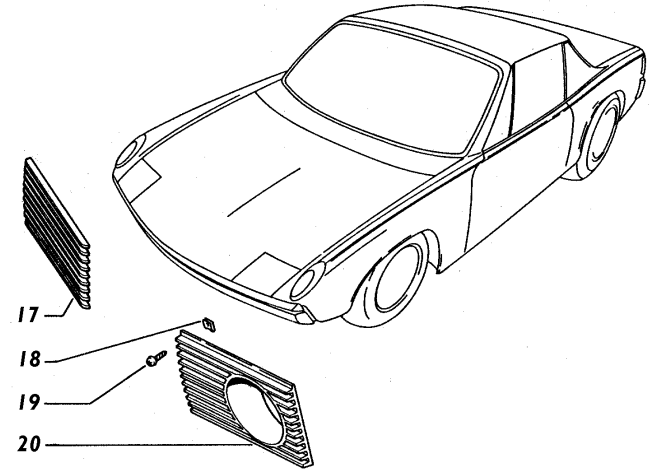
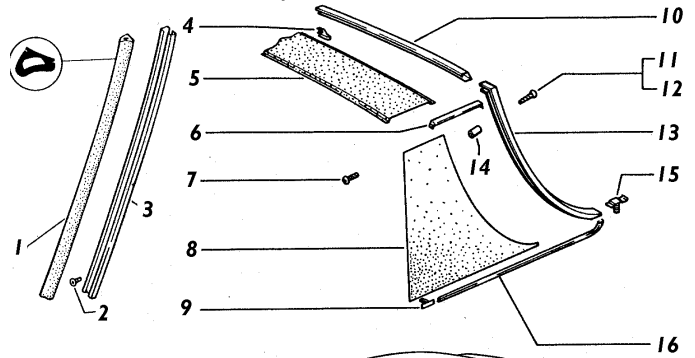

Tech Tip 516: Roll bar side vinyl should always be reinstalled with spray trim adhesive to avoid lumpiness. Also, never install the vinyl until the new paint finish has cured several weeks as the glue can easily lift the paint.

Tech Tip 520: Four clips secured the lower roll bar chrome to the quarter panel, while three clips secured the rear lateral chrome strip to the roll bar.

914 & 914-6 Body

914 & 914-6 Body

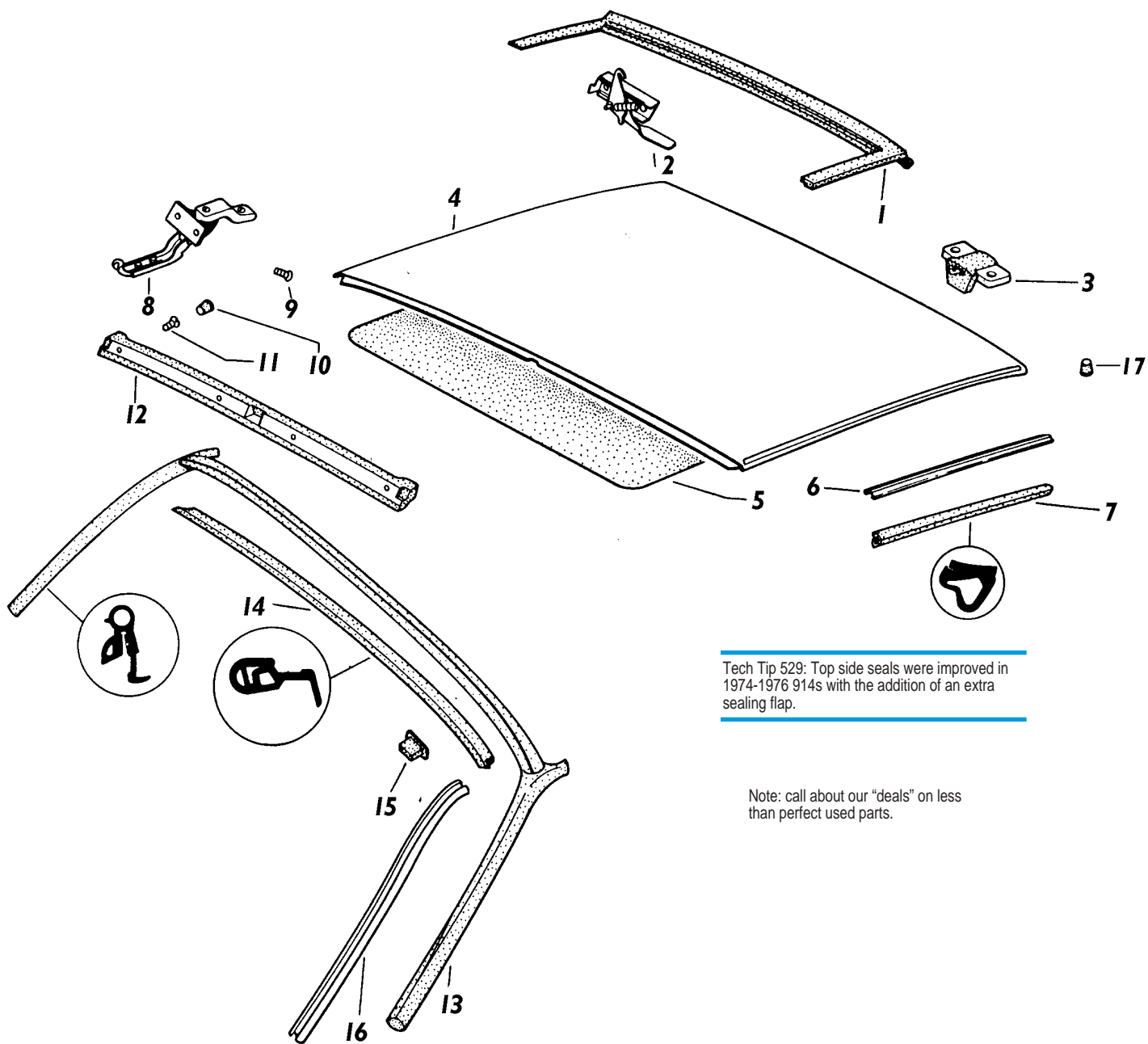

Tech Tip 529: Top side seals were improved in 1974-1976 914s with the addition of an extra sealing flap.

Note: call about our "deals" on less than perfect used parts.

Description	Part Number	Gen.	Repl.	Used	Rep./Reb.
1 Roll Bar Seal Up To 1973 Chassis 473 283 6221	914.563.077.10	\$481.58	\$297.00	\$95.00	\$75.00
Roll Bar Seal From 1973 Chassis 473 282 6222	914.563.077.11	\$481.58	\$297.00	\$95.00	\$75.00
2 Lock, Left Rear	914.563.081.11	\$150.73	--	\$75.00	--
Lock, Right Rear	914.563.082.11	\$150.73	--	\$75.00	--
3 Rear Top Catch	914.563.033.19	--	--	\$60.00	--
4 Top	914.563.901.11	\$1,512.71	--	\$600.00	--
5 Interior Roof Lining	914.563.921.11	\$46.66	--	--	\$27.50
6 Clamping Strip For Top/door Glass Sealing Left	914.531.865.10	\$29.37	--	\$12.00	--
Clamping Strip For Top/door Glass Sealing Right	914.531.866.10	\$29.37	--	\$12.00	--
7 Sealing B/T Top/door Glass, Left 1974-76	914.531.185.10	\$84.61	\$63.52	\$17.00	\$38.50
Sealing B/T Top/door Glass, Right 1974-76	914.531.186.10	\$84.61	\$63.80	\$17.00	\$38.50
8 Lock, Front	914.563.071.10	\$102.06	--	\$95.00	--

Description	Part Number	Gen.	Repl.	Used	Rep./Reb.
9 Lens Head Csk Screw Am 5x15	900.148.012.02	\$1.00	\$1.00	--	--
Lens Head Csk Screw Am 5x12	999.148.005.04	\$4.29	\$1.00	--	--
10 Interior Plug	914.552.233.10	\$3.60	--	\$2.00	--
11 Lens Head Sheet Metal Screw	N0.139.575	\$2.00	\$1.10	--	--
12 Front Top Bolster 1970-72	914.563.021.12	\$368.90	--	\$130.00	--
Front Top Bolster 1973-76	914.563.021.13	\$368.90	--	\$130.00	--
13 Top Sealing 1974-76	914.563.039.10	\$375.00	--	--	\$199.50
14 Lower W/S Seal	914.563.319.10	\$146.15	\$93.50	\$44.00	--
15 Filling Piece For Ski Holders, Left 1970-73	914.559.239.10	\$29.29	--	\$16.00	--
16 Clamping Strip W/s Post Sealing, Left 1970-73	914.531.823.11	\$38.98	--	\$26.00	--
Clamping Strip W/s Post Sealing, Left 1974-76	914.531.823.11	\$38.98	--	\$26.00	--
17 Rear Ski Rack Plug	999.703.087.40	\$6.00	--	\$4.00	--

914 HARD PARTS

914 & 914-6 Body

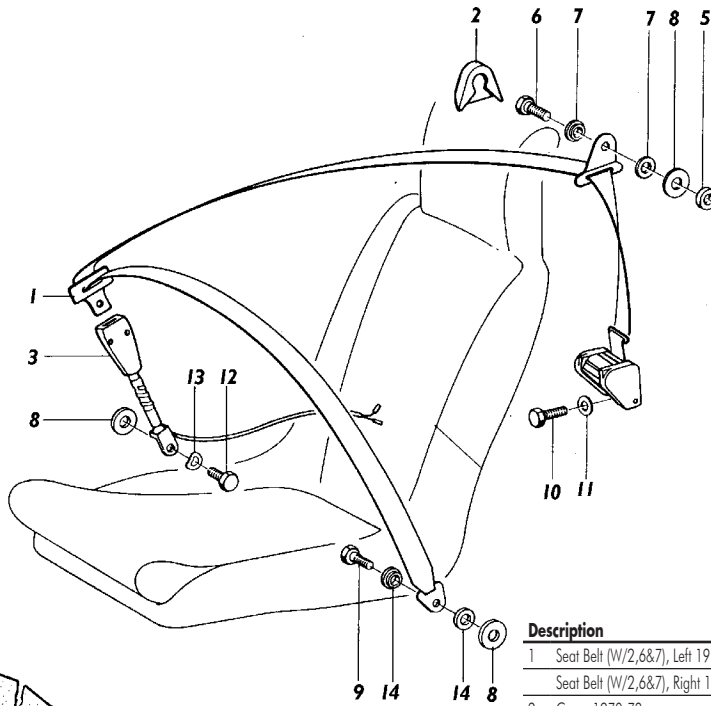

Tech Tip 533: If the retractable seat belts do not roll back easily, do not take them apart! The spring assembly is tightly wound and could cause injury if opened. Extend the belt fully, wash with soap and water, and allow to dry. Next, lubricate the belt with Scotchgard, which will allow it to more readily roll upon itself. Finally, if all fails, replace the belt.

Tech Tip 537: The factory made an extra seat belt set for a child sitting on the center seat cushion. The kit mounts into the two inner seat belt holster mounting holes. The part number for this kit is 914 803 021 10.

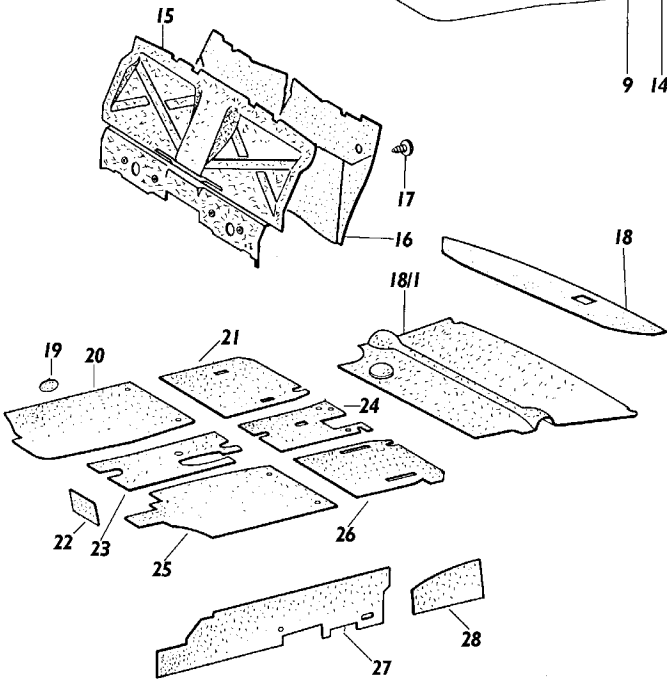

Description	Part Number	Gen.	Repl.	Used	Rep./Reb.
1 Seat Belt (W/2,6&7), Left 1970-73	914 803 181 10	\$299.00	--	\$125.00	--
Seat Belt (W/2,6&7), Right 1970-73	914 803 182 10	\$299.00	--	\$125.00	--
2 Cover 1970-73	901 803 134 20	\$7.65	--	\$4.50	--
Cover 1974-76	911 803 233 01	\$7.83	--	\$4.50	--
3 Lock 1970-76	914 803 183 11	\$152.01	--	\$53.00	--
5 Spacer	914 803 137 10	\$3.49			
6 Screw 1970-73	901 803 146 00	\$9.74	--	\$6.00	--
Screw 1974-76	111 857 793 E	\$6.89	--	--	--
7 Washer 1970-73	901 803 147 00	\$1.00	--	--	--
Washer 1974-76	211 857 771	\$1.00	--	--	--
8 Washer	111 857 707 A	\$4.61	--	--	--
9 Screw 1970-73	901 803 119 22	\$4.73	--	--	--
Screw 1974-76	111 857 793 E	\$6.89	--	--	--
10 Screw	111 857 799	\$3.60	--	--	--
11 Safety Washer	999 523 109 02	\$1.00	--	--	--
12 Screw 1970-73	901 803 119 20	\$4.58	--	--	--
Screw 1974-76	914 803 468 10	\$5.30	--	--	--
13 Spring Washer	900 028 026 01	\$1.00	--	--	--
14 Washer 1970-73	111 857 771 A	\$1.00	--	--	--
Washer 1974-76	211 857 771	\$1.00	--	--	--
15 Lining 1970-71	914 556 129 10	\$230.87	--	\$75.00	--
Lining 1972-76	914 556 129 11	\$230.87	--	\$75.00	--
16 Engine Insulator Pad	914 556 135 10	\$361.36	--	\$150.00	\$199.50
17 Plastic Plug	914 559 377 10	\$3.50	--	--	--
18 Cover For Luggage Compartment	914 556 265 10	--	--	--	\$38.50
Heat Insulation Lining, Rear	914 556 003 10	\$137.75	--	\$85.00	\$46.75
19 Lining	914 556 109 10	--	--	--	\$45.00
20 Lining, Front Right	914 556 114 10	\$227.42	--	--	\$45.00
21 Lining, Rear Right 1970-71	914 556 116 10	--	--	--	\$45.00
Lining, Rear Right 1972-76	914 556 116 11	--	--	--	\$45.00
22 Lining, Pedal Wall	914 556 125 10	--	--	--	\$45.00
23 Lining, Front	914 556 119 10	\$210.00	--	--	\$45.00
24 Lining, Tunnel 1970-71	914 556 128 10	--	--	--	\$45.00
Lining, Tunnel 1972-76	914 556 128 11	--	--	--	\$45.00
25 Lining, Front Left	914 556 113 10	\$26.44	--	--	\$45.00
26 Lining, Rear Left	914 556 115 10	--	--	--	\$45.00
27 Lining, Left	914 556 117 10	\$242.25	--	--	--
Lining, Right	914 556 118 10	\$242.25	--	--	--
28 Lining, Wheel Case Left	914 556 121 10	\$150.00	--	--	--
Lining, Wheel Case Right	914 556 122 10	\$150.00	--	--	--

Our fabulous new 6-piece floor pan tar kit includes 20, 21, 23, 24, 25 and 26, perfectly die-cut for easy installation!

B914 556 110 KT ... [\\$175.00](#)

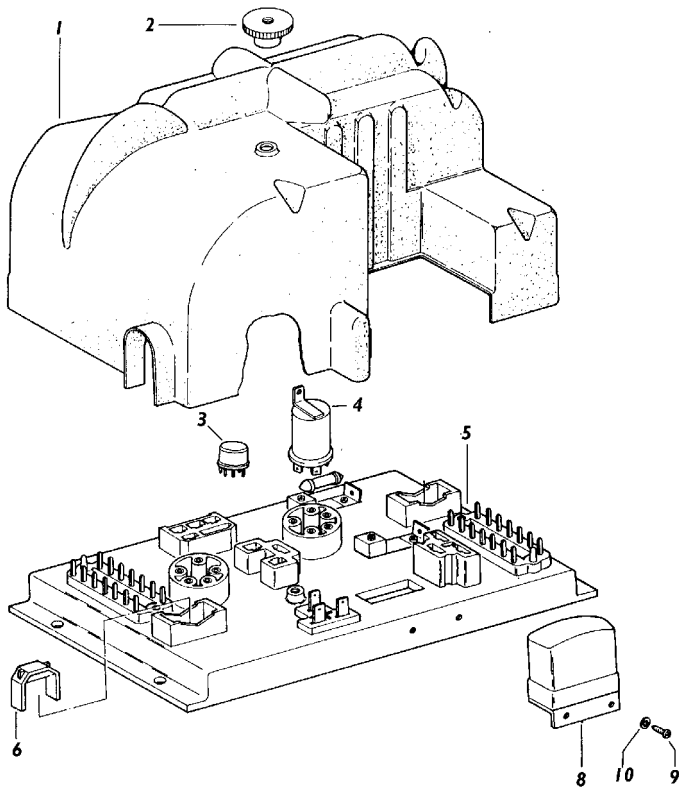

Tech Tip 54: All voltage regulators (even new ones) do not output the same voltage. Ideal charging voltage is 13.6 volts.

Tech Tip 545: If the alternator light glows dimly and all grounds are firmly connected, an alternator diode is failing. Rebuilding the alternator is the solution.

Description	Part Number	Gen.	Repl.	Used	Rep./Reb.
1 Relay Board Cover 1970-72	914 610 111 11	\$78.12	--	\$40.00	--
Relay Board Cover 1973-76	914 610 111 13	\$56.28	--	\$36.00	--
2 Nut M5 To Chassis 475 290 0924	900 241 011 02	--	--	\$15.00	--
3 Universal Round Relay	911 615 109 01	\$27.31	\$22.49	\$15.00	--
4 Additional Unit Bkz 914-6	901 602 601 00	--	--	\$175.00	--
5 Relay Board, 914-6	914 610 103 00	\$1,525.88	--	\$650.00	\$450.00
Relay Board, 914-4	914 610 104 00	\$1,464.05	--	\$425.00	\$350.00
6 Clamp	914 610 107 00	--	--	\$16.50	--
7 Ground Strap, Engine Housing To Alt.	901 612 110 00	\$20.38	--	--	--
8 Voltage Regulator Screened, 914-6	043 903 803 B	\$106.27	\$43.45	\$15.00	--
9 Lens Head Sheet Metal Screw	900 143 108 02	\$1.00	\$1.00	--	--
10 Washer B3.7	900 151 034 02	--	\$1.00	--	--
11 Cheese Head Screw M10x110, 914-6	900 067 074 02	\$4.90	\$2.89	--	--
Bolt, Hex Hd M10x115, 914-4	N0 105 003	\$4.65	\$2.31	--	--
12 Cheese Head Screw M10x150	900 067 078 02	\$8.00	\$2.31	--	--
13 Support	022 903 646	\$15.59	--	\$9.00	--
14 Spring Washer	N0 122 283	\$1.00	\$1.10	--	--
15 Square Nut M8	021 903 243 A	\$4.36	\$2.31	--	--
16 Starter, 914-6	923 604 101 00	\$604.57	--	\$110.00	\$192.50
Starter, 914-4	039 911 023	\$833.08	--	\$95.00	\$123.00
17 Starter Boot	999 659 006 50	\$6.50	--	--	--
18 Hexagon Nut M14x1.5	N0 111 633	\$4.76	--	--	--
19 Washer 15	N0 115 653	\$1.00	--	--	--
20 Pulley For Threephase Alternator	021 903 109 A	\$77.39	--	\$35.00	--
21 Threephase Alternator, 914-6	911 603 118 00	\$769.42	--	--	\$324.50
Threephase Alternator, 914-4	022 903 023	\$178.52	--	\$75.00	\$115.00
22 V Belt	068 903 137 D	\$17.66	\$7.51	--	--
23 Bolt M8x71	021 903 231	\$3.49	--	\$6.50	--
24 Bracket	022 903 645	\$6.45	--	\$4.00	--
25 Gasket For Alternator	022 903 203	\$2.39	--	--	\$4.50
26 Gasket For Intake Cover	021 903 637	--	--	--	--
27 Intake Cover For Alternator	021 903 621	\$73.38	--	\$25.00	--
28 Cables From Regulator To Alt.	021 971 349 D	\$245.10	--	\$75.00	--
29 Hose Conn. Strip For Elbow 1970-71	021 903 659	\$4.00	\$1.73	--	--
Hose Conn. Strip For Elbow 1972-76	021 903 659 A	\$4.00	\$1.73	--	--
30 Conn. Elbow For Intake Cover 1970-71	021 903 655	\$26.30	--	--	--
Conn. Elbow For Intake Cover 1972-	021 903 655 B	\$26.30	--	--	--

* All Rebuilt Parts Require A Rebuildable Core.

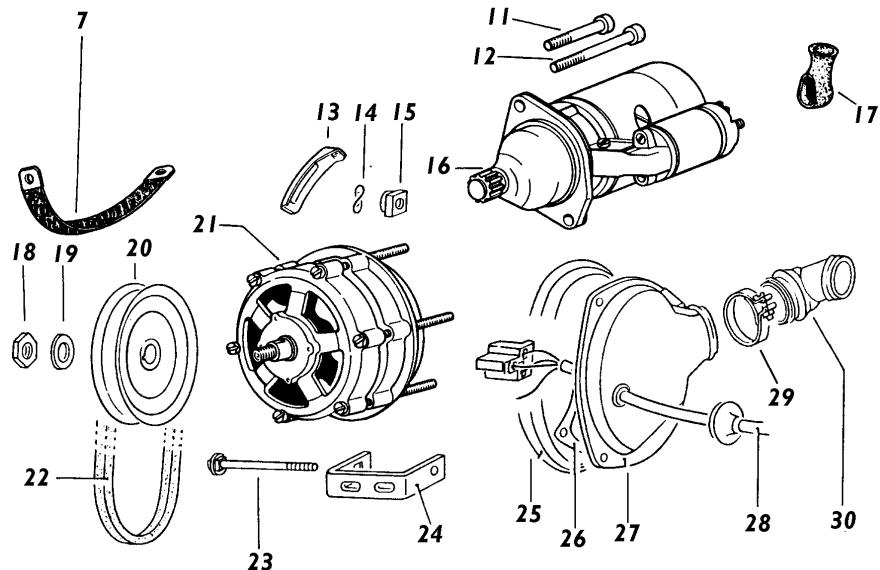

914 HARD PARTS

914 & 914-6 Electrical

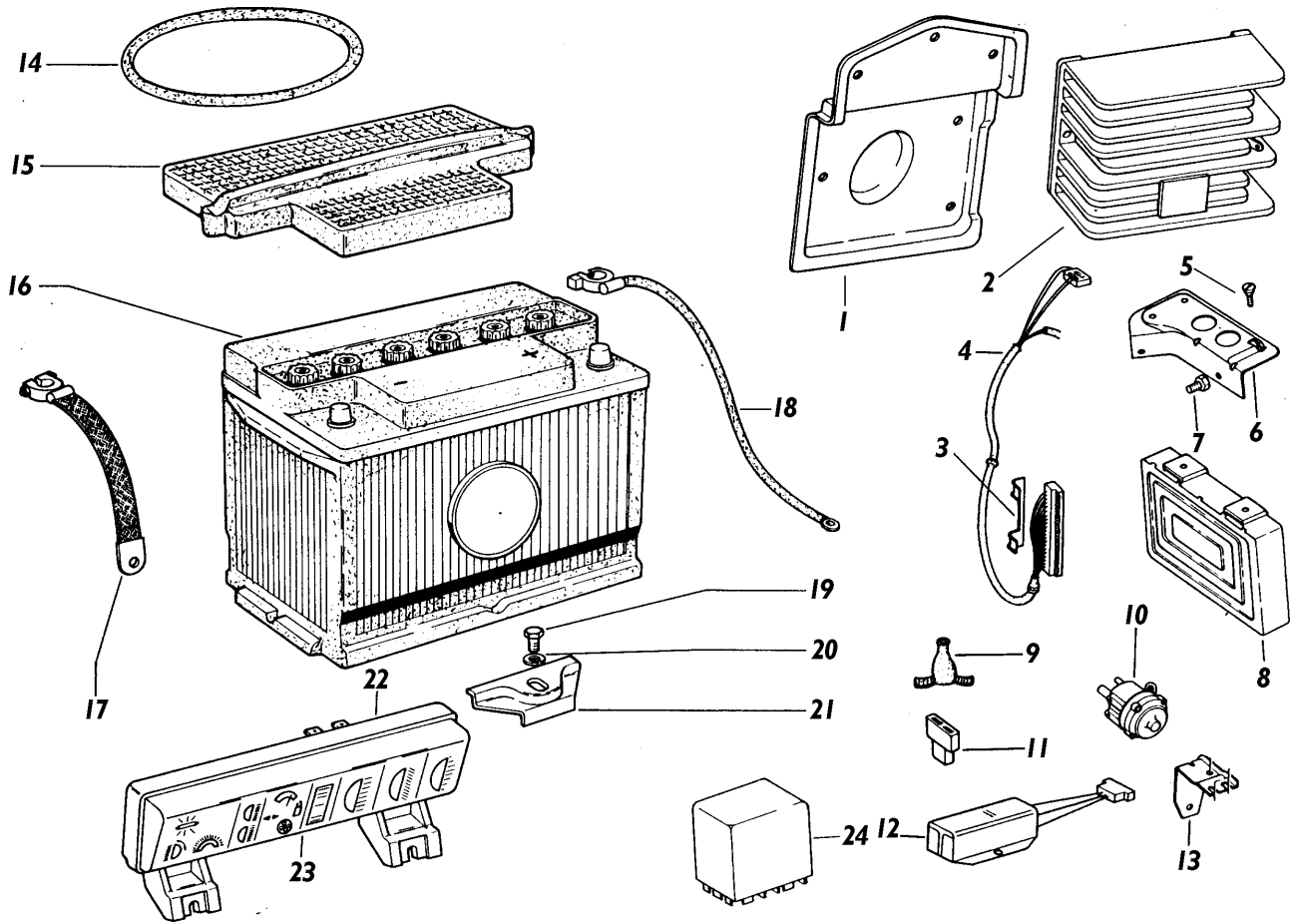

Tech Tip 575: The 1.8 engine uses a completely different ignition harness than the 1.7 and 2.0 models and will not interchange. In addition, 74 and 75 1.8 models use different injection harnesses (designated by 6 pin and 7 pin airflow meter plugs) and these will not interchange.

Description	Part Number	Gen.	Repl.	Used	Rep./Reb.	Description	Part Number	Gen.	Repl.	Used	Rep./Reb.
1 Bracket For 914-6 Ignition Unit	914.602.011.00	\$90.26	--	--	\$45.00	11 Connecting Plug 2 Pole	022.906.231.A	\$6.49	--	--	--
2 914-6 Ignition Control Unit	901.602.702.00	\$1,933.93	\$381.75	--	\$380.50	Connecting Plug 2 Pole	311.906.231.A	\$4.00	--	--	--
3 Handle Connector In Control Unit	022.906.209	\$29.64	--	--	--	Connecting Plug 3 Pole	311.906.231.B	\$4.40	--	--	--
4 Cables From Control Unit 1.7	022.971.761.G	\$541.32	--	\$250.00	--	Connecting Plug 4 Pole	311.906.231.C	\$4.74	--	--	--
Cables From Control Unit 1.8	022.971.761.Q	\$528.62	--	\$250.00	--	Connecting Plug 5 Pole	311.906.231.D	\$4.94	--	--	--
Cables From Control Unit 2.0	039.971.761.B	\$665.59	--	\$375.00	--	Connecting Plug 6 Pole To Eng Ec0037551	022.906.233.A	\$4.40	--	--	--
5 Lens Head Screw	914.618.114.10	\$6.00	--	--	--	Connecting Plug 3 Pole	022.906.233.B	\$18.91	--	--	--
6 Control Unit Bracket	914.618.01310	\$80.53	--	--	--	Connecting Plug 7 Pole From Eng Ec0037552	071.906.233	\$18.07	--	--	--
7 Bolt, Hex Hd M6x10	N0.102.1013	\$2.00	\$1.16	--	--	12 Resistor On Battery Carrier	022.906.079	\$127.58	--	\$75.00	--
8 Control Unit 1.7	022.906.021.B	\$1,342.79	--	\$250.00	\$495.00	13 Supporting Angle	914.618.119.10	\$59.86	--	\$35.00	--
Control Unit 2.0	022.906.021.E	\$1,342.79	--	\$250.00	\$495.00	14 Retaining Ring	010.409.549.B	\$8.38	--	--	--
Control Unit 1.8	022.906.021.G	\$1,187.70	--	\$250.00	\$495.00	15 Battery Cover	914.611.116.00	\$31.85	--	--	--
9 Protect Cap Connecting Plug 2 Pole 1.8	022.906.102	\$13.00	--	--	\$12.00	16 Battery 12v 45ah	000.056.007	\$150.26	\$85.08	--	--
Protect Cap Connecting Plug 6 Pole 1.8	022.906.102.B	\$4.97	--	--	\$12.00	17 Ground Strap For Battery & Body	914.611.903.10	\$39.19	--	--	\$24.20
Protect Cap Connecting Plug 3 Pole 1.8	022.906.102.C	\$4.76	--	--	--	18 Battery Starter Cable	914.611.031.00	\$90.52	--	--	\$28.60
Protect Cap Connecting Plug 7 Pole 1.8	022.906.102.D	\$4.15	--	--	--	19 Bolt, Hex Hd M8x35	N0.102.477	\$1.00	\$1.00	--	--
Protect Cap Connecting Plug 2 Pole 1.7 2.0	311.906.102.A	\$29.50	--	--	\$12.00	20 Spring Ring	900.027.015.02	\$1.00	\$1.00	--	--
Protect Cap Connecting Plug 3 Pole 1.7 2.0	311.906.102.B	\$29.50	--	--	\$12.00	21 Battery Clamp	914.611.233.10	\$14.09	\$9.66	--	--
Protect Cap Connecting Plug 4 Pole 1.7 2.0	311.906.102.C	\$29.50	--	--	\$12.00	22 Fuse Box 12-pole	914.612.315.10	\$111.46	\$55.00	--	--
Protect Cap Connecting Plug 5 Pole 1.7 2.0	311.906.102.E	\$29.50	--	--	\$12.00	23 Cover For Fuse Box	914.612.316.10	\$44.49	--	--	\$29.50
10 Pressure Sensor 2.0	039.906.051	\$1,370.97	\$715.00	\$245.00	\$275.00	24 Dual Relay 1.8	071.906.059.A	\$123.22	\$83.16	\$44.00	--
Pressure Sensor 1.7	944.606.103.00	\$1,411.18	\$770.00	\$95.00	\$275.00						

* All Rebuilt Parts Require A Rebuildable Core

914 & 914-6 Electrical

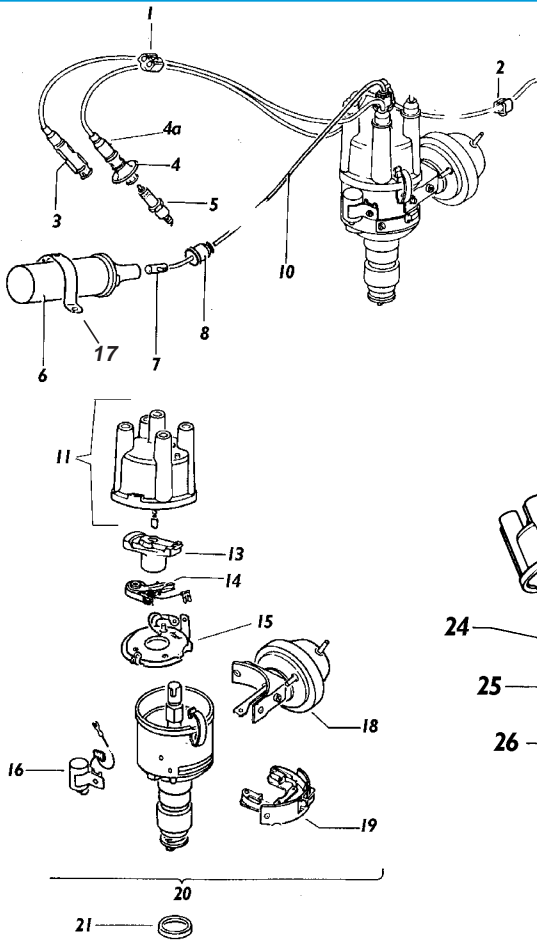

Tech Tip 585: The 914-6 models were equipped with both Bosch (German made) and Marelli (Italian made) distributors. The Bosch unit is far superior to the Marelli, and tune-up parts are much cheaper and more readily available. When replacing a worn distributor, always replace it with a Bosch unit.

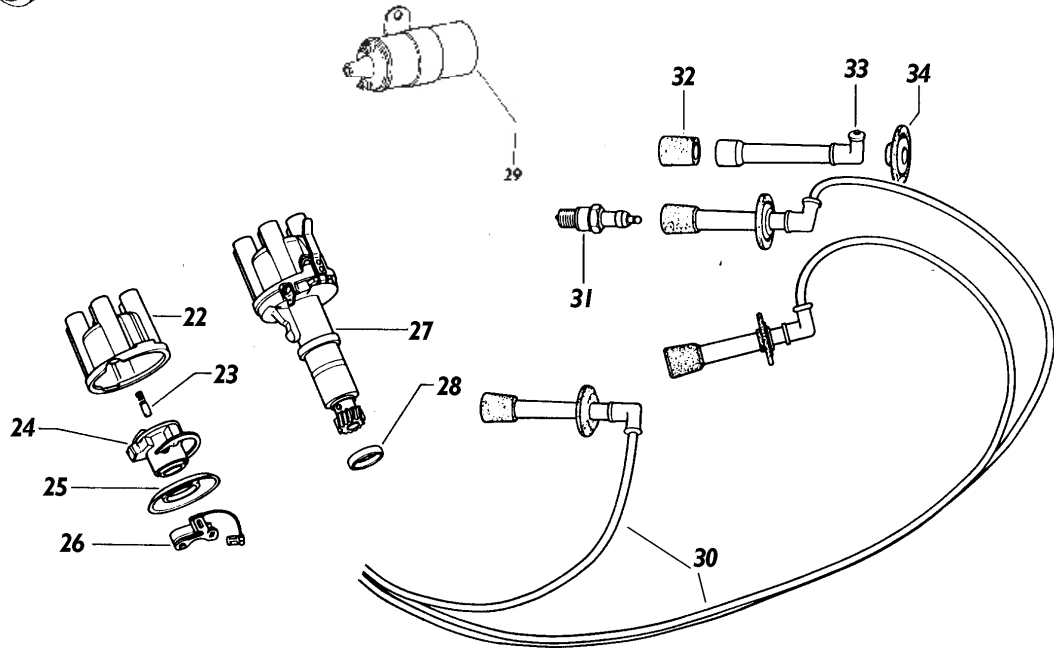

Description	Part Number	Gen.	Repl.	Used	Rep./ Reb.
1 Ignition Wire Clip 2 Wire	113.905.451.A	\$3.21	\$2.31	--	--
2 Ignition Wire Clip 1 Wire	111.201.261	\$6.00	--	--	--
3 Ignition Wire Connector Cyl 1&3	113.035.255.A	\$10.84	--	--	--
Ignition Wire Connector Cyl 4	021.035.255	\$10.09	--	--	\$4.95
Ignition Wire Connector Cyl 2	021.035.255.B	\$9.06	--	--	\$4.95
4 Ignition Wire Boot	311.905.429.A	\$4.00	\$3.46	--	--
4A Ignition Wire Boot	111.905.449.A	\$5.02	\$3.46	--	\$2.20
5 Spark Plug 175 Bosch W7CC, 1.7	N.178.111.9	\$4.84	\$2.60	--	--
Spark Plug 225 Bosch W7DP	N.178.113	\$4.84	\$2.60	--	--
Spark Plug 145 Bosch W7DC, 1.8, 2.0	N.178.118	\$5.49	\$2.60	--	--
6 Ignition Coil 12V To Eng W0057460	022.905.115	\$61.96	\$29.60	\$15.00	--
7 Clamping Strip For Ign. Coil From Eng GA0006766 To Eng GB 0007402 To Eng GC0000001 To Eng AN0000001 To Eng EC0000001 To Eng GA0016000	021.905.119	\$15.95	--	\$6.00	--
8 Cap For Ignition Cable	311.905.429.A	\$4.00	\$3.46	--	--
10 Ignition Wireset 1.7, 1.8	021.998.031.A	\$104.44	\$35.14	--	--
Ignition Wireset 2.0	039.998.031	--	\$40.15	--	--
11 Distributor Cap	113.905.207.C	\$20.24	\$7.64	--	--
13 Rev. Limiting Rotor	022.905.225.A	\$63.46	\$25.97	--	--
Regular Rotor	043.905.225	\$63.46	\$4.95	--	--
14 Breaker Points For Dist.	311.998.063	\$12.71	\$6.50	--	--
16 Condenser For Distributor, 1.7, 2.0	311.905.295.C	\$19.79	\$7.50	--	--
Condenser For Distributor, 1.8	311.905.295.B	\$19.79	\$7.50	--	--
18 Vacuum Advance For Dist. #1	022.905.271.A	\$227.60	\$153.45	\$150.00	--
Vacuum Advance For Dist. #2	022.905.271.B	\$227.60	--	\$150.00	--
Vacuum Advance For Dist. #2,3,&4	022.905.271.C	\$225.83	--	\$150.00	--
Vacuum Advance For Dist. #1A	022.905.271.D	\$164.20	--	\$150.00	--
Vacuum Advance For Dist. #5	039.905.271	\$193.20	--	\$150.00	--
19 Contact Breaker Plate W/trigger contacts	311.905.301	\$181.04	\$124.00	--	--

Description	Part Number	Gen.	Repl.	Used	Rep./ Reb.
20 Distributor #1 For All 914s Engine #W0000001-W0057459 To W0000001-W0129581 To EA0000001-EA0057000	022.905.205.F	\$863.34	--	\$350.00	--
Distributor #1A For 914 1.8 Engine #EC0037552	022.905.205.AB	\$590.42	--	\$250.00	--
Distributor #2 For All 914 & 1.7 Engine #W0057460-W0250000	022.905.205.H	\$863.34	--	\$350.00	--
Distributor #3 For 914 1.7 & 2.0 Engine #EA0057001-EA0098793 To EB0000001-EB0010020	022.905.205.P	\$863.34	--	\$350.00	--
Distributor #4 For 914 2.0 Engine #GB0000001-GB0007401 To GA0000001-GA0006765	039.905.205	\$1,211.56	--	\$350.00	--
Distributor #5 For 914 2.0 Engine #GB0007402-GA000676 to GA0016000	039.905.205.A	\$1,203.41	--	\$350.00	--
21 Sealing Ring For Distributor	111.905.261	\$4.02	\$2.74	--	--
22 Distributor Cap, Bosch, 914-6	911.602.933.00	\$26.73	\$15.95	--	--
Distributor Cap, Marelli, 914-6	901.602.953.00	--	--	--	\$95.00
24 Distributor Rotor, Bosch, 914-6	911.602.928.00	\$32.58	\$25.41	--	--
Distributor Rotor, Marelli, 914-6	901.602.928.01	--	--	--	\$95.00
25 Dust Cap, 914-6	901.602.927.00	\$9.18	\$6.35	--	--
26 Set Of Breaker Points, Bosch, 914-6	616.602.226.02	\$28.05	\$11.75	--	--
Set Of Breaker Points, Marelli, 914-6	901.602.932.00	\$28.66	\$10.97	--	--
27 Distributor, 914-6	911.602.022.00	\$964.50	--	--	--
28 Seal Ring, 914-6	999.701.101.50	\$2.48	\$2.31	--	--
29 Ignition Transformer For BHKZ, 914-6 Coil	901.602.502.00	\$304.64	\$92.50	--	--
30 Ignition Cables, 914-6, Set	911.609.061.00	\$123.64	\$113.19	--	--
31 Spark Plug, Bosch, USA 914-6 W4DPO	999.170.008.90	\$28.56	\$13.86	--	--
33 Spark Plug Connector For 914-6	901.609.309.00	\$50.58	--	--	--
34 Spark Plug Air Seal	111.905.449.A	\$5.02	\$3.46	--	--

914 HARD PARTS

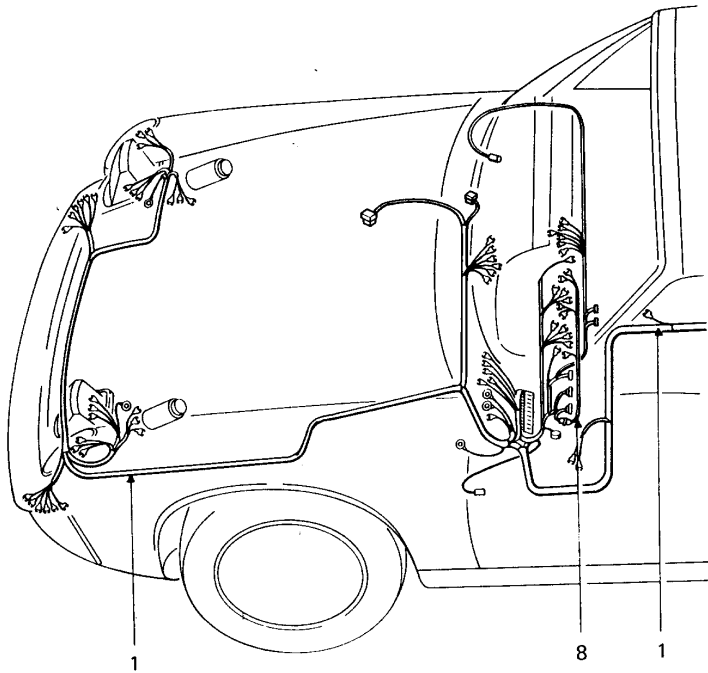

Tech 611: Always make sure the rear transmission ground strap is firmly connected. If not, the starter will turn slowly and possibly the accelerator cable will melt its sheath as the starter seeks this cable as its ground.

Tech Tip 612: It is possible to touch the brake light switch wiring to the accelerator cable causing a strange short and a warm, sticking, cable.

Tech Tip 616: Never leave the key in the "on" position. If the ignition points happen to be closed, they will cause the coil lead to short and melt the ignition harness.

Tech Tip 618: A separate harness, relay, and modified wiper switch, can be easily added to all 72-76 914 models to achieve intermittent wiper action.

If you get in a jam and need a partial wiring harness to repair your 914, call us!

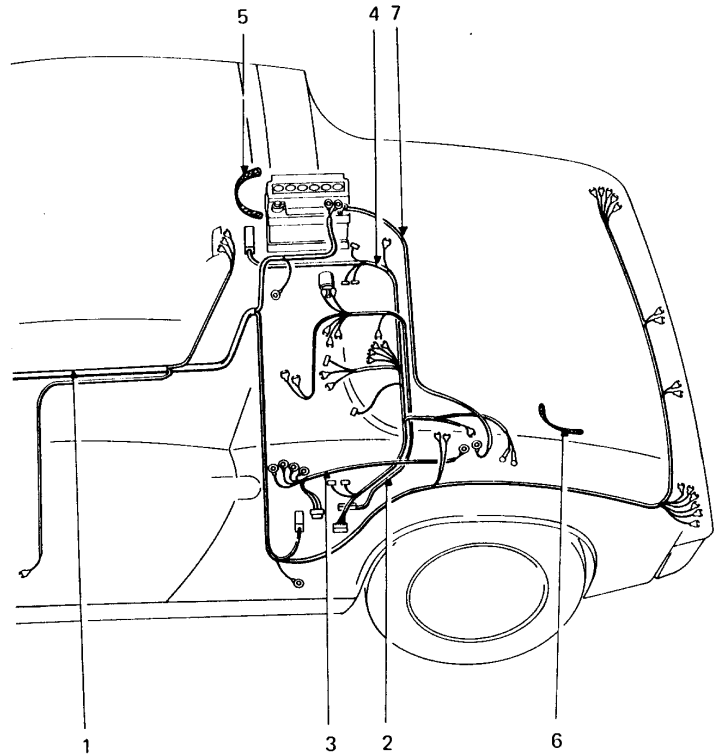

note: used wiring harnesses are not perfect!

Description	Part Number	Gen.	Repl.	Used	Rep./Reb.
1 Main Wiring Harness 1970 914.4	914 612 021 10	\$2,193.40	--	\$450.00	--
Main Wiring Harness 1971 914.4	914 612 021 12	\$2,193.40	--	\$450.00	--
Main Wiring Harness 1972 914.4	914 612 021 14	\$2,005.97	--	\$450.00	--
Main Wiring Harness 1973 914.4	914 612 021 15	\$2,005.97	--	\$450.00	--
Main Wiring Harness 1974 914.4	914 612 021 16	\$2,863.62	--	\$450.00	--
Main Wiring Harness 1975-76 914.4	914 612 021 17	\$2,863.62	--	\$450.00	--
Main Wiring Harness 1970-71 914-6	914 612 047 10	\$3,852.00	--	\$1,000.00	\$1,950.00
Main Wiring Harness 1972 914-6	914 612 018 13	\$2,895.36	--	\$1,250.00	--
2 Engine Wiring Harness 1970-72, 914, 1.7	914 612 007 10	\$499.05	--	\$350.00	--
Engine Wiring Harness 1973-76, 914, 1.7, 2.0	914 612 007 15	\$499.05	--	\$350.00	--
Engine Wiring Harness 1974-75, 914, 1.8	914 612 016 16	\$325.78	--	\$350.00	--
Engine Wiring Harness 1970-72, 914-6	914 612 046 10	\$679.65	--	--	--
3 Cables From Regulator To Alt.	021 971 349 D	\$145.10	--	\$75.00	--
4 Cables For Control Unit 1970-71	022 971 819	\$521.31	--	\$250.00	--
Cables For Control Unit From 1972	022 971 761 F	\$540.66	--	\$250.00	--
Cables For Control Unit To Eng EC0037551	022 971 761 G	\$541.32	--	\$250.00	--
Cables For Control Unit Eng. EC0037552	022 971 761 Q	\$528.62	--	\$250.00	--
Cables For Control Unit G80000001-GA0016000	039 971 761 B	\$665.59	--	\$375.00	--
Cables For Control Unit (California)	039 971 761 A	\$505.33	--	--	--
5 Ground Strap 1970-73	914 611 903 10	\$29.19	\$25.51	--	\$24.20
Ground Strap 1974-76	914 611 904 11	\$24.32	--	--	\$24.20
6 Ground Strap (Gear Box To Chassis)	999 611 919 20	\$19.95	--	--	\$7.15
7 Cable From Battery To Starter	914 611 031 00	\$90.52	\$63.52	--	\$28.60
8 Cables For Instrument Illumination	914 612 041 20	\$220.92	--	--	--

914 & 914-6 Electrical

Description	Part Number	Gen.	Repl.	Used	Rep./Reb.
1 Covering 914-6	914 613 163 00	\$9.16	--	\$50.00	--
2 Steering Lock W/o Starter & Ignition Switch W/o Buzzer Contact W/keys (No Lock #)	964 347 917 01	\$560.50	\$479.75	\$275.00	--
3 Combined Starter & Ignition Switch	911 613 017 01	\$104.17	\$49.95	\$25.00	--
4 Cap W/symbol, Transparent, Red	113 941 543 E	\$34.70	--	\$15.00	--
5 Handle, 1970-71	411 953 245 A	\$17.98	--	\$9.00	--
Handle, 1972-76	411 953 245 A	\$17.98	--	\$9.00	--
6 Plate M 14x1	111 941 515 D	\$10.61	--	\$3.00	--
7 Switch For Warning Light	411 953 235 B	\$156.96	--	\$45.00	--
8 Headlight Cap W/symbol (USA)	113 941 543 B	\$12.50	--	--	--
9 Knob, 1970-71	111 941 541 F	\$13.72	--	\$9.00	--
Knob, 1972-76	111 841 541 F	\$17.26	--	\$9.00	--
10 Light Switch 1970-71	914 613 414 10	\$531.60	--	\$295.00	--
Light Switch 1972-76	914 613 414 15	\$551.37	--	\$290.00	--
11 Fuel Tank Sensor	901 741 801 00	\$214.52	\$95.00	\$50.00	--
12 Cap W/symbol Transparent, Green For Heated Rear Window	411 941 543 C	\$32.39	--	--	--
13 Cap W/symbol Transparent, Yellow For Fog Tail Lamp & Fog Light	111 941 543 H	\$32.39	--	--	--

Description	Part Number	Gen.	Repl.	Used	Rep./Reb.
14 Handle, 1970-71	914 613 435 10	\$24.31	--	\$7.00	--
Handle, 1972-76	111 953 245 E	\$14.06	--	\$6.00	--
15 Switch For Single Stage Fog Light, Rear Window Heating, And Fog Tail Lamp	914 613 419 11	\$47.47	--	\$35.00	--
16 Cap W/symbol For Cigarette Lighter	911 613 235 01	\$7.39	--	--	--
17 Glow Filament For Cig Lighter	914 652 901 10	\$29.50	--	--	--
18 Cigarette Lighter	Pcg 652 104 11	\$79.64	--	\$35.00	--
19 Washer	914 652 115 10	\$2.50	--	--	--
20 Release Button 70-71 Washer Switch	914 613 428 10	\$14.50	--	\$4.95	--
21 W/S Wiper Switch	141 955 517 A	\$48.72	--	\$18.00	--
22 Ornamental Switch Chrome	901 613 114 00	\$28.68	--	\$10.00	--
23 Switch For Ventilation System	914 613 134 13	\$341.13	--	\$75.00	--
24 Joint Ring	477 919 113 A	\$6.05	--	--	--
25 Signal Horn, Hella 335hz	191 951 113 A	\$199.65	--	\$75.00	--
Signal Horn, Hella 400hz	914 951 113 A	\$208.72	--	\$75.00	--
Signal Horn, Hella 400hz 75-76	944 637 103 01	\$40.86	\$29.50	\$23.00	--
26 Water Prot. Cap For Oil Switch	999 659 009 40	\$8.65	--	--	--
27 Oil Press. Switch 914-6	911 606 203 00	\$10.89	\$9.50	--	--
Oil Press. Switch 914-4	021 919 081 B	\$14.56	\$9.50	--	--
28 Temperature Switch 914-6	905 613 102 04	\$39.23	--	--	--
29 Seal Ring	900 123 007 30	\$1.00	--	--	--
30 Stop Light Switch	901 613 411 00	\$78.31	--	--	--
31 Contact Switch (Hand Brake)	968 613 601 00	\$9.03	\$8.70	\$6.00	--
Contact Switch (Door) 1970-73	113 947 561 E	\$9.20	--	\$6.60	--
Contact Switch Door 1974-76	968 613 601 00	\$10.89	--	\$6.00	--
32 Gasket	944 613 114 00	\$4.33	\$1.21	--	--
33 Relay For Wiper Control 1970-76	477 955 531 A	\$80.07	\$70.40	\$45.00	--
34 Back Up Light Switch	914 613 541 02	\$88.40	\$69.75	\$30.00	--
35 Reverse Light Switch Boot	914 613 491 00	\$11.02	--	--	--
36 Oil Temp Send Unit, 914-6	901 641 632 00	\$31.39	--	--	--
37 Relay For Lower Beam	111 941 583	\$34.54	\$24.14	\$15.00	--
38 Universal Round Relay	911 615 109 01	\$27.31	\$22.49	\$15.00	--
39 Blinker Relay	914 618 303 10	\$106.48	\$39.50	--	--

* Different From Original Factory

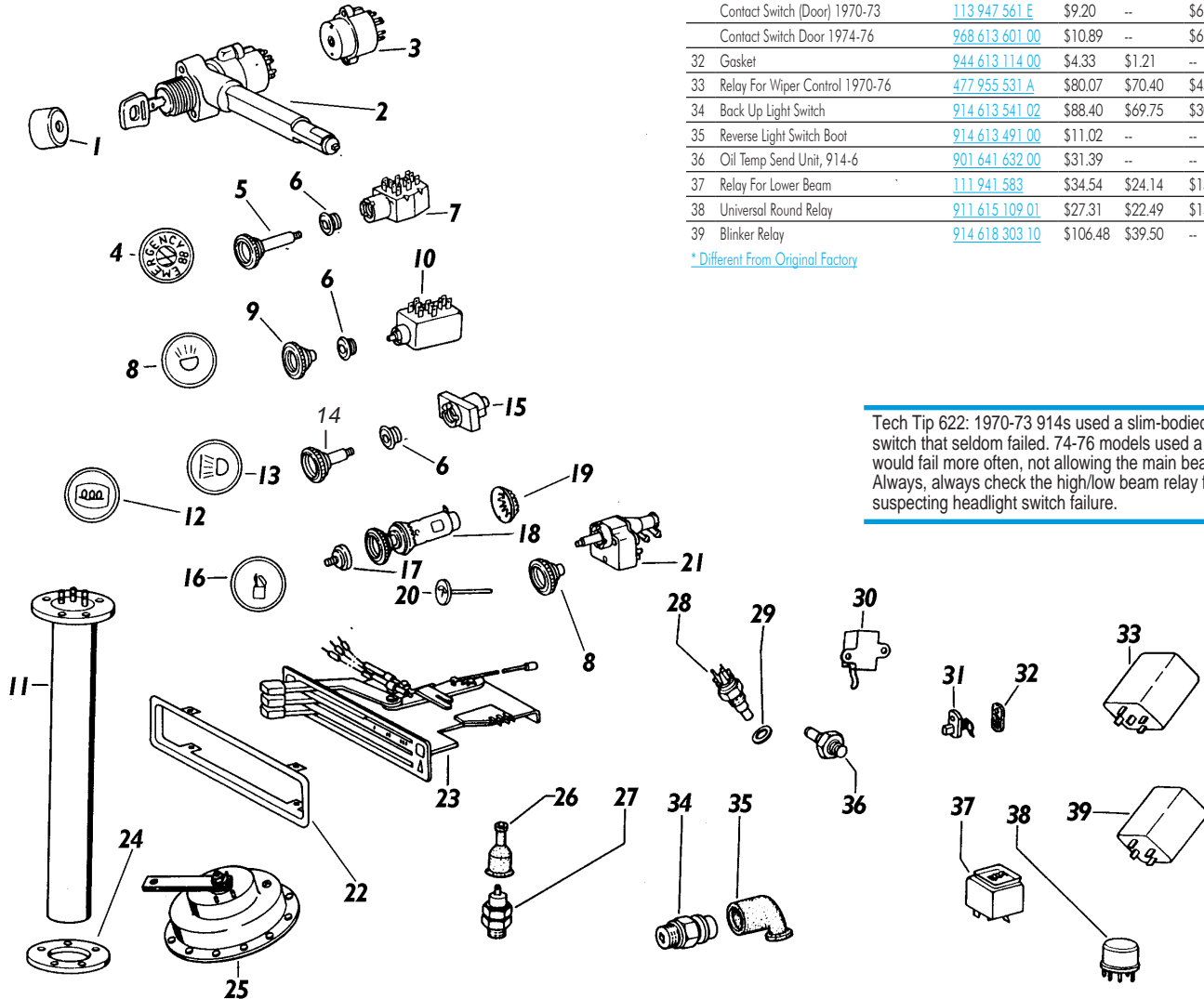

Tech Tip 622: 1970-73 914s used a slim-bodied headlight switch that seldom failed. 74-76 models used a fat switch that would fail more often, not allowing the main beams to light. Always, always check the high/low beam relay first before suspecting headlight switch failure.

914 HARD PARTS

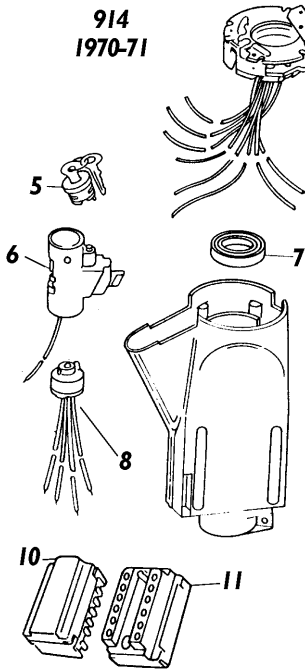

Tech Tip 658: If the turn signals do not cancel, you have one of two problems: The steering wheel horn contact rim or steering wheel is on upside down; or, the two canceling fingers in the turn signal switch are broken. The latter entails replacement of the switch.

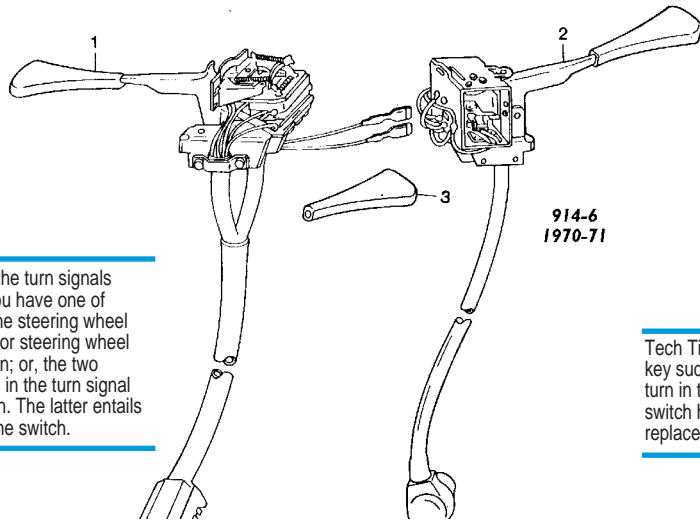

Tech Tip 650: If the ignition key suddenly becomes hard to turn in the tumbler, the ignition switch has melted and needs replacement.

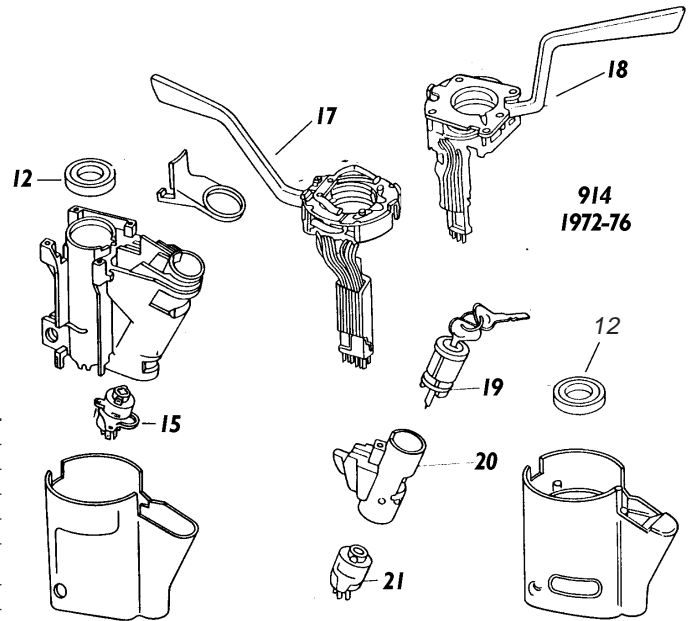

Description	Part Number	Gen.	Repl.	Used	Rep./Reb.
1 Blinker, Dim., Flasher W/park Lt, 914-6	914 613 303 10	\$409.65	--	\$250.00	--
2 Switch For W/s Wiper/washer, 914-6	914 613 302 10	\$447.67	--	\$200.00	--
3 Handle For Switch, 914-6 1971	901 552 853 00	\$46.93	--	--	--
4 Switch, Upper Part, 1970 Turn Signal	914 613 927 12	\$91.29	\$65.98	--	--
5 Locking Cylinder W/keys (W/o Lock #) 1970	914 347 903 00	\$86.40	--	\$45.00	--
6 Lock Cyl. W/keys (State Lock #) 1971-76 Ch.4712909637	914 347 904 02	\$126.60	--	--	\$62.11
7 Combined Steering And Ignition Switch 1970 914	113 905 887	\$87.82	--	\$38.00	--
8 Steering Lock W/o Combined Steering & Ignition Switch 1971-74	111 905 851 N	\$136.25	--	\$50.00	--
9 Ball Bearing	900 052 202 00	\$24.62	--	--	--
10 Combined Starter & Ign. Switch 1970	311 905 865 A	\$52.74	\$40.42	--	--
11 Combined Starter & Ign. Switch W/buzzer Contact 1971	311 905 865 B	\$56.12	--	--	--
12 Multiple Plug 12 Pole 1970	911 612 121 03	\$35.09	--	\$19.00	--
13 Multiple Plug 14 Pole 1971	911 612 113 05	\$46.74	--	\$25.00	--
14 Conn. 12 Pole Steer Col. Switch 1970	911 612 122 02	\$33.20	--	\$19.00	--
15 Conn. 14 Pole Steer Col. Switch 1971	911 612 115 02	\$46.74	--	\$19.00	--
16 Ball Bearing 1975-76	911 347 771 02	\$43.27	\$29.64	--	--
17 Comb. Starter & Ign. Switch 1975-76	111 905 865 L	\$40.56	\$21.67	--	--
18 Blinker System Switch 1972-74	914 613 913 14	\$90.31	\$125.00	\$85.00	--
19 Blinker System Switch 1975-76	914 613 913 15	\$85.99	\$95.00	--	--
20 W/S Wiper/washer Switch 1972-76	914 613 915 14	--	\$250.00	\$125.00	--
21 W/S Wiper/washer Switch 1975-76	914 613 915 15	\$202.71	\$250.00	\$98.90	--
22 Locking Cyl. W/keys (No Lock #) 1972-76	914 347 903 02	\$136.25	--	\$65.50	--
23 Steering Lock 1972-74	111 905 851 N	\$136.25	--	\$50.00	--
24 Comb. Starter & Ign. Switch 1972-74	111 905 865 K	\$50.20	\$17.60	--	--

Tech Tip 644: If the red and green warning lights go off when turning the key to the start position and the car does not start, the ignition switch is bad.

Tech Tip 645: If the horn only operates when the steering wheel is turned slightly off center, the two finger (75-76 models, have a single finger) copper contact on the turn signal switch is bad. To restore proper horn operation, the turn signal switch must be replaced.

914 & 914-6 Electrical

914 & 914-6 Electrical

Description	Part Number	Gen.	Repl.	Used	Rep./Reb.
1 Wiper Motor Two Stage, 1970-71 914-4	914 628 020 10	\$416.83	\$317.62	\$150.00	--
Wiper Motor Two Stage, 1972-76 914-4	914 628 020 13	\$615.73	\$317.62	\$150.00	--
2 Crank Mechanism W/o Engine W/ Fig 6-11 & 19, 914-6	914 628 012 20	\$632.25	--	\$450.00	--
Crank Mechanism W/o Motor W/ Fig 6-11 & 19, 914-4	914 628 011 20	\$316.44	--	\$250.00	--
3 W/S Wiper Arm, Straight (SWF), Left 914-6	914 628 313 10	\$37.53	\$40.42	\$10.00	--
4 W/S Wiper Arm, Angular, (SWF) Right 914-6	914 628 314 10	\$38.29	\$36.38	\$10.00	--
5 Wiper Blade, SWF or Bosch	964 628 901 01	--	\$10.99	--	--
6 Washer	901 628 922 00	\$6.18	--	--	--
7 Rubber Bushing	901 628 923 01	\$11.63	--	--	--
8 Rubber Bushing	901 628 924 00	\$7.49	--	--	--
9 Hexagon Nut	901 628 925 00	\$12.07	--	\$5.00	--
10 Protective Cap	901 628 926 00	\$5.91	--	--	--
11 Spring Washer	803 955 437	\$1.00	--	--	--
12 Hexagon Nut M6	900 076 010 02	\$1.00	\$1.10	--	--
13 Spring Ring	914 628 901 00	\$1.00	--	--	--
14 W/S Wiper Motor 914-6	914 628 019 10	\$452.68	--	\$300.00	--
15 Wiper Rack Mount	914 628 113 00	\$29.50	--	--	--
16 Carbon, 914-6	914 628 906 00	\$15.89	--	--	--
17 Armature, 914-6	914 628 908 00	\$67.34	--	--	--
Armature, 914-4	914 628 907 00	\$67.34	--	--	--
18 Carbon Holder Plate, 914-6	914 628 903 00	\$30.31	--	--	--
Carbon Holder Plate, 914-4	901 628 905 00	\$1.00	--	--	--
19 Cap Nut For Wiper Arm Fastening	901 628 341 00	\$8.75	\$5.78	--	--
20 Brush Holder Plate, 914-4	901 628 902 00	\$24.20	--	--	--
21 Carbon, 914-6	901 628 904 00	\$5.89	--	--	--
24 W/S Washer Fluid Container, 914-6	914 628 080 10	\$171.52	--	--	--
25 PVC Hose, State Length, 914-6	914 628 901 10	\$4.56	\$3.46	--	--
26 Electric W/s Washer Pump, 914-6	823 955 651	\$87.56	\$39.95	\$30.00	--
27 Plug, 914-6	914 628 741 00	\$7.37	--	--	--
28 Nozzle, Chrome 914-6	644 628 741 02	\$32.59	\$17.32	--	--
Nozzle, Black 914-6	914 628 203 11	\$7.37	\$6.60	--	--
29 W/S Washer Fluid Container, 914-4	914 628 075 12	\$68.85	\$25.00	--	--
30 Hose, 914-4	914 628 022 10	--	--	\$25.00	--
30a Connecting Hose	914 628 021 10	\$28.10	--	--	--
31 Nut For Hose	113 955 481	\$1.00	--	--	--

Tech Tip 667: The straight wiper arm bolts to the left driver's wiper shaft and the wiper arm with the bend bolts to the passenger's side shaft.

Tech Tip 668: If the chrome wiper rack securing nuts are exposed, the plastic wiper caps are missing and need to be replaced to keep the nuts from rusting.

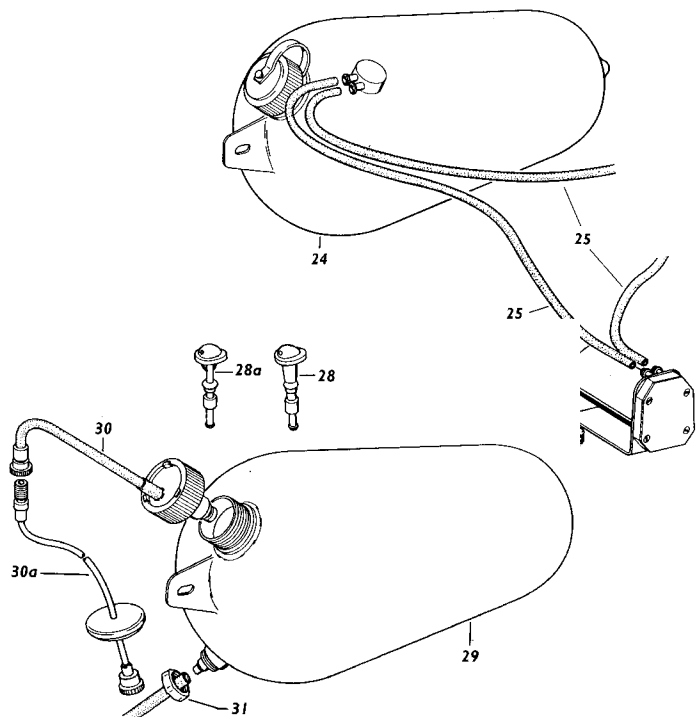
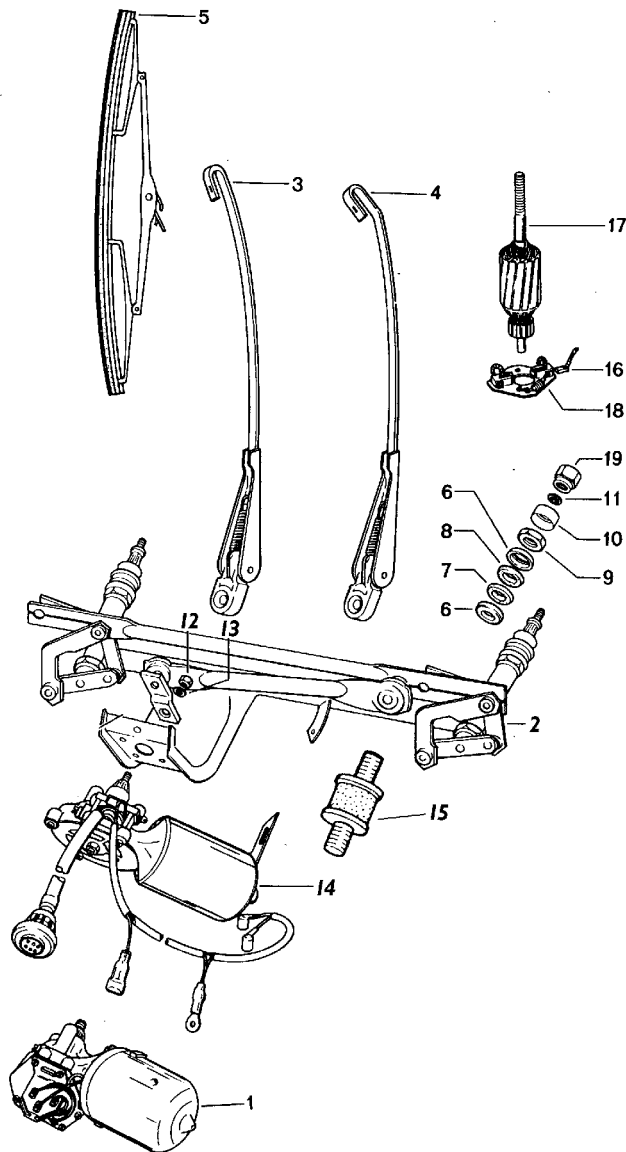

Tech Tip 677: If your lap becomes soaked when using the windshield washer, the hoses have deteriorated and must be replaced.

914 HARD PARTS

Description	Part Number	Gen.	Repl.	Used	Rep./Reb.
1 Position Light (USA) w/out lens	914 631 401 11	\$484.78	--	\$55.00	--
2 Headlight Lens W/ Screw (USA)	914 631 934 11	\$79.94	--	\$16.00	--
3 Rubber Seal	914 631 957 10	\$45.18	--	--	\$12.00
4 Lens Head Screw	914 631 958 10	\$6.38	--	\$2.50	--
5 Bulb, 12v-21w/5w	900 631 128 90	\$6.24	\$3.30	--	--
Bulb, 12v 32/3 Cp	999 631 115 90	\$7.45	\$1.73	--	--
6 Sleeve For Wire Harness, T/S Lens	914 631 217 10	\$28.78	--	--	--
7 Light Bracket	914 631 215 10	\$16.37	--	\$10.00	--
8 Luggage Compartment Lamp	901 631 601 00	\$45.23	\$26.44	\$10.00	--
9 Bulb, 12v 4w	900 631 103 90	\$3.89	\$2.20	--	--
10 Lens Head Screw Am 4x10	900 146 011 02	\$1.00	--	--	--
11 "Fasten Seat Belt" Light 1970-72	911 632 012 00	\$62.47	--	\$15.00	--
"Fasten Seat Belt" Light 1974-76	911 632 012 01	\$21.56	--	\$15.00	--
12 Insignia For Heater Control Lever	914 632 107 00	\$36.84	--	\$21.00	--
13 Bulb, 12v 2cp	999 631 104 91	\$1.58	--	--	--
14 Sidemarker Lens, Left	914 631 405 00	\$77.99	--	\$45.00	--
Sidemarker Lens, Right	914 631 946 00	\$23.30	--	\$15.00	--
15 Sidemarker Assy, Left	914 631 405 00	\$77.99	--	\$45.00	--
Sidemarker Assy, Right	914 631 408 00	\$29.50	--	\$15.00	--
Sidemarker Seal	914 631 945 00	--	--	--	\$8.80
16 Protection Cap	914 631 946 00	\$39.50	--	--	\$25.00
17 Overhead Tapping Screw	900 143 016 02	\$27.81	\$34.04	\$15.00	--
18 Taillight Lens, Left (Euro) Amber/Red	914 631 949 10	\$7.50	--	--	--
Taillight Lens, Right (Euro) Amber/Red	914 631 950 10	\$1.89	\$2.20	--	--
Taillight Lens, Left (USA) Red	914 631 939 11	\$1.89	\$2.20	--	--
Taillight Lens, Right (USA) Red	914 631 940 11	--	\$10.95	--	--
Taillight Lens, Left (France) Amber	914 631 947 12	\$1.98	\$2.20	--	--
Taillight Lens, Right (France) Amber	914 631 948 12	\$22.66	\$16.44	--	--
18a Taillight Lens Seal	914 631 939 00	--	--	--	\$16.50
19 Bulb, 12v 32cp	900 631 127 90	\$11.50	--	--	--
20 Bulb, 12v 32/3	999 631 115 90	\$40.86	--	\$30.00	--
21 Bulb, 12v 32cp	900 631 127 90	\$45.64	--	\$30.00	--
22 Bulb, 12v 4w	900 631 103 90	\$1.00	--	--	--
23 License Plate Light 1970-74	914 631 601 00	\$27.81	\$34.05	--	--
24 Reverse Light Grommet	111 971 911 A	\$9.50	--	--	--
25 Bulb, 12v 4w 1970-74	900 631 103 90	--	--	--	--
26 Bulb, 12v 10w	900 631 106 90	--	\$12.70	--	--
27 Interior Light	111 947 111 E	\$33.32	\$12.70	--	--
28 1975-76 License Plate Bulb, 5w	900 631 104 90	\$2.20	\$1.50	--	--
29 License Plate Light 1975-76	911 631 620 04	\$22.66	\$16.44	--	--
30 Gasket 1975-76	911 631 608 00	\$2.29	--	--	--
31 Lens For Lic. Plate Light 1975-76	914 631 606 00	\$11.50	--	--	--
32 Headlight Surround, Left	914 750 225 11	\$40.86	--	\$30.00	--
Headlight Surround, Right	914 750 226 11	\$45.64	--	\$30.00	--
33 Tapping Screw B3.5x13	900 145 004 02	\$1.00	--	--	--
34 Filister Head Screw W/pivot	341 941 183 A	\$1.00	\$1.00	--	--
35 Headlight Ring	914 631 107 20	\$54.69	--	\$24.00	--
36 Sealed Beam Headlamp 60/50w (USA)	111 941 261 B	\$33.32	\$12.70	--	--
Headlamp H-4	914 631 164 00	\$107.87	\$51.98	--	--

Description	Part Number	Gen.	Repl.	Used	Rep./Reb.
37 Bulb, H4	999 631 202 90	\$26.71	\$10.97	--	--
38 Headlight Relay Cover, Left	914 750 195 10	\$21.22	--	\$10.00	--
Headlight Relay Cover, Right	914 750 196 10	\$21.22	--	\$12.60	--
39 Covering, Left 1972-76	914 750 265 10	\$17.48	--	\$10.00	--
Covering, Right 1972-76	914 750 266 10	\$17.48	--	\$10.00	--
Headlight Rod Brush Strip 1970-72	914 750 079 10	\$27.34	--	--	--
40 Headlamp Motor, Left	914 624 113 11	\$346.04	--	\$145.00	--
Headlamp Motor, Right	914 624 114 11	\$329.93	--	\$145.00	--
41 Button For Motor	914 624 117 00	\$6.59	--	\$3.00	--
42 Halogen Bulb, H3 6/12v 55w 1975-76	900 631 126 90	--	\$9.75	--	--
43 Gasket For Additional Foglamp	914 631 914 10	--	--	--	\$13.20
44 Foglight Lens, White (USA)	914 631 913 11	\$43.13	--	--	--
45 Retainer Ring	914 631 917 10	\$31.51	--	\$21.00	--
46 Elastic Spring	914 631 924 10	\$1.00	--	--	--
47 Retaining Spring	914 631 961 10	\$1.73	--	--	--
48 Lens Head Screw W/pivot Am 4x10	914 631 920 10	\$1.00	\$1.16	--	--
49 Foglight Assembly, White (USA)	914 631 134 11	\$172.72	--	\$100.00	--
50 Bulb, 12v 35w 1970-74	900 631 130 90	\$15.23	\$13.86	--	--
51 Screw Cheesehead M8x45	900 074 134 02	\$1.00	--	\$1.50	--
52 Foglight Bracket, Left	914 631 029 10	\$38.44	--	\$20.00	--
Foglight Bracket, Right	914 631 030 10	\$37.72	--	\$20.00	--
53 Spring Washer	N0 122 301	\$1.00	--	\$1.00	--
54 Screw Cheesehead M10x16	900 186 125 02	\$1.43	\$1.16	--	--
55 Pivot Pin, 1970-76, 3 Hole	914 750 271 10	\$24.80	--	\$15.00	--
56 Triple Pole Plug	911 631 108 00	\$1.33	\$1.00	--	--
57 Foglight Retainer, Left 914-4	914 631 011 10	\$408.35	--	\$175.00	--
Headlight Retainer, Right 914-4	914 631 012 10	\$397.73	--	\$175.00	--
58 Outer Headlamp Mounting, 1970-76	914 750 165 10	\$24.10	--	\$10.00	--
59 Headlamp Housing, Left	914 750 131 10	\$169.80	--	\$75.00	--
Headlamp Housing, Right	914 750 132 10	\$169.80	--	\$75.00	--

* Without Lens And Gasket

914 & 914-6 Electrical

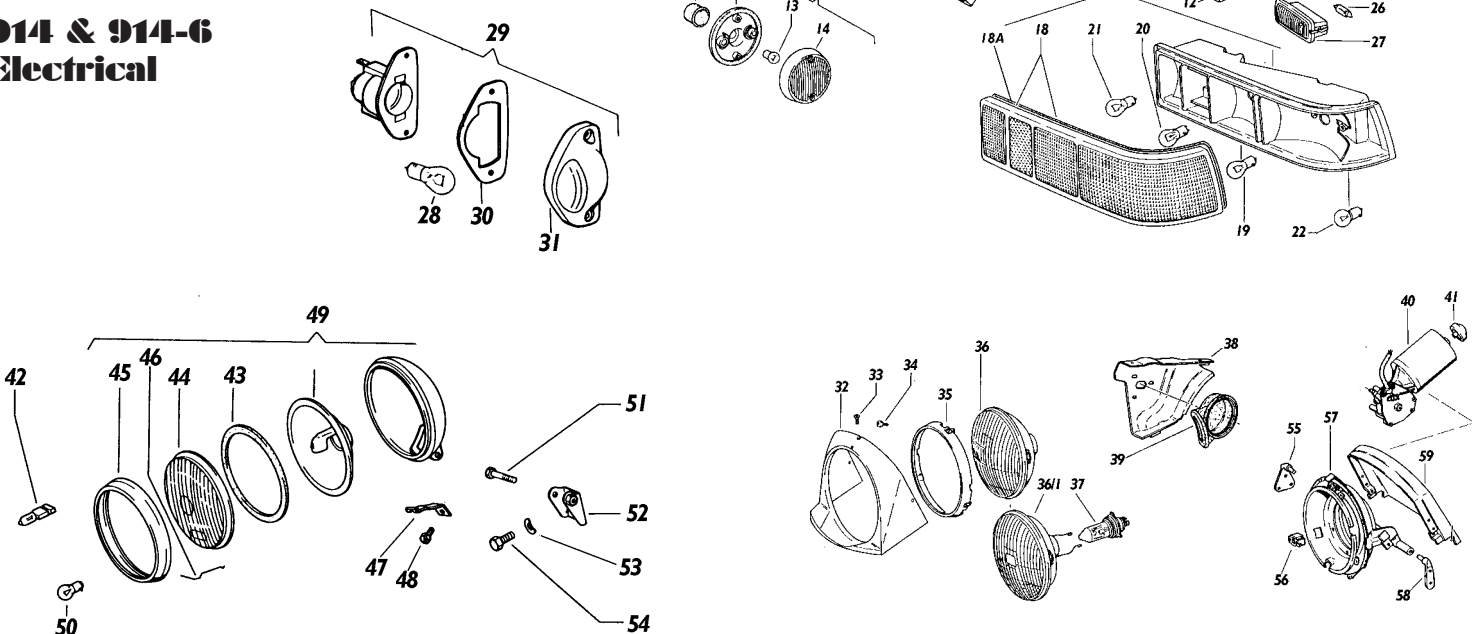

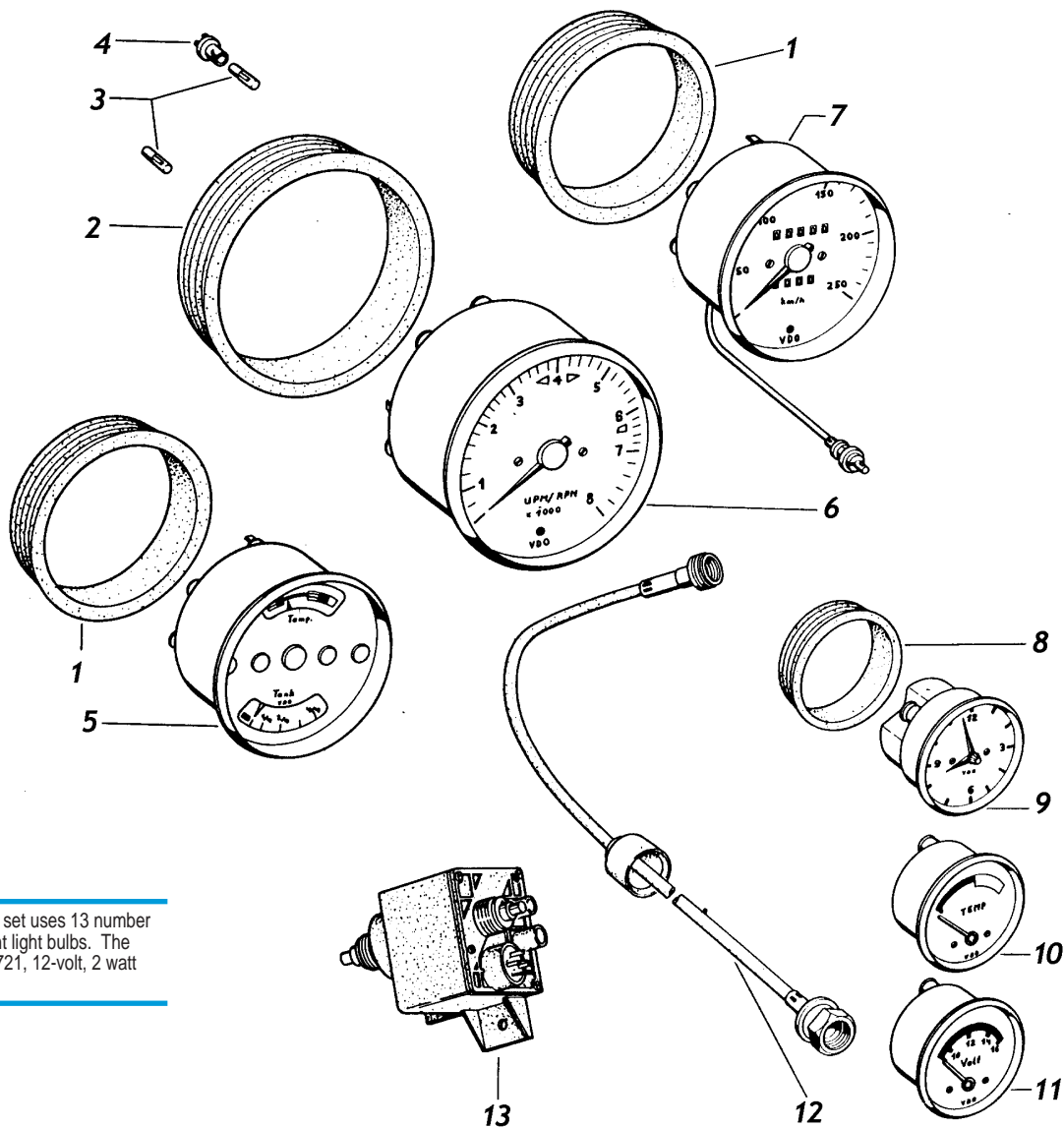

Tech Tip 719: The 70-74 914 gauge set uses 13 number 3898, 12-volt, 2 watt large instrument light bulbs. The late 74-76 models use 13 number 2721, 12-volt, 2 watt small instrument light bulbs.

Description	Part Number	Gen.	Repl.	Used	Rep./Reb.
1 Rubber Ring 100 Mm	911 641 902 00	\$8.21	--	\$4.00	--
2 Rubber Ring 115 Mm	911 641 903 00	\$8.12	--	\$4.00	--
3 Bulb 12v-2w, Small Inst.	900 631 102 90	\$3.02	\$1.44	--	--
4 Bulb Holder Bi-polar	999 632 009 10	\$6.60	--	\$3.00	--
5 Combined Instrument, 914-6 Gas/Temp.	914 641 101 20	\$326.14	--	\$250.00	--
Combined Instrument For Middle Con. Fuel/Temp.	914 641 101 30	\$371.51	--	\$175.00	\$265.00
Combined Inst. W/Middle Con. From 74 Fuel	914 641 101 50	\$371.51	--	\$175.00	\$265.00
Combined Inst. From 74, 1.8 (Op. 2.0) Temp./Fuel	914 641 102 50	\$371.51	--	\$275.00	\$265.00
Combined Inst. 70-73 1.7 (Op.2.0) Temp./Fuel	914 641 102 40	\$433.10	--	\$275.00	\$265.00
6 Tachometer, 914-6	914 641 301 10	\$396.70	--	\$175.00	\$253.14
Tachometer, 70-73, 1.7/2.0	914 641 302 10	\$331.66	--	\$175.00	\$253.14

Description	Part Number	Gen.	Repl.	Used	Rep./Reb.
Tachometer, 74-76, 1.8/2.0	914 641 302 12	\$448.46	--	\$175.00	\$265.00
7 Speedometer Mileage, 914-6 (165x15 Tires)	911 641 506 00	\$469.85	--	--	\$192.50
Speedometer Mileage, 914-4 (155x15 Tires)	914 641 503 11	\$451.99	--	--	\$192.50
Speedometer 120 MPH, 914-4 (165x15 Tires)	914 641 504 10	\$456.31	--	\$150.00	\$192.50
Speedometer 150 MPH, 1973-74 914	914 641 504 20	\$456.31	--	\$150.00	\$192.50
Speedometer 150 MPH, 1974.5-76 914	914 641 504 30	\$6.31	--	\$150.00	\$192.50
8 Rubber Ring 60 Mm	911 641 909 00	\$17.44	--	\$9.00	--
9 Clock	914 641 119 10	\$219.68	--	\$185.00	\$214.50
10 Oil Temperature 1.7/2.0 Up To 73	914 641 118 20	\$157.68	--	\$150.00	--
Oil Temperature 1.8/2.0 1974-76	914 641 118 30	\$158.33	--	\$150.00	--
11 Voltmeter	914 641 115 10	\$496.47	--	\$160.00	--
12 Speedo Cable	914 641 111 00	\$111.11	\$55.00	--	--
13 Counter Switch 1975-76 (California)	914 641 123 10	\$93.95	--	--	--

* All Rebuilt Parts Require A Rebuildable Core

914 HARD PARTS

Tech Tip 723: If the fresh air fan ceases to operate, check the following:

1. Clean the sliding ground contacts on the fresh air switch below the ashtray.
2. Check fuse number eight (the fifth one from the right passenger's side) for a good connection.
3. Check the black round relay on the back of the fuse block.
4. Check the large red with white wire at the blower box for power. If this wire has power and the three grounds at the switch are making connection, remove and clean, or replace the blower.

Tech Tip 724: 73-76 fresh air blower boxes had a screen installed just under the cowl intake to keep debris from entering the box. It is advisable to install this screen in the earlier models to insure longer blower motor life.

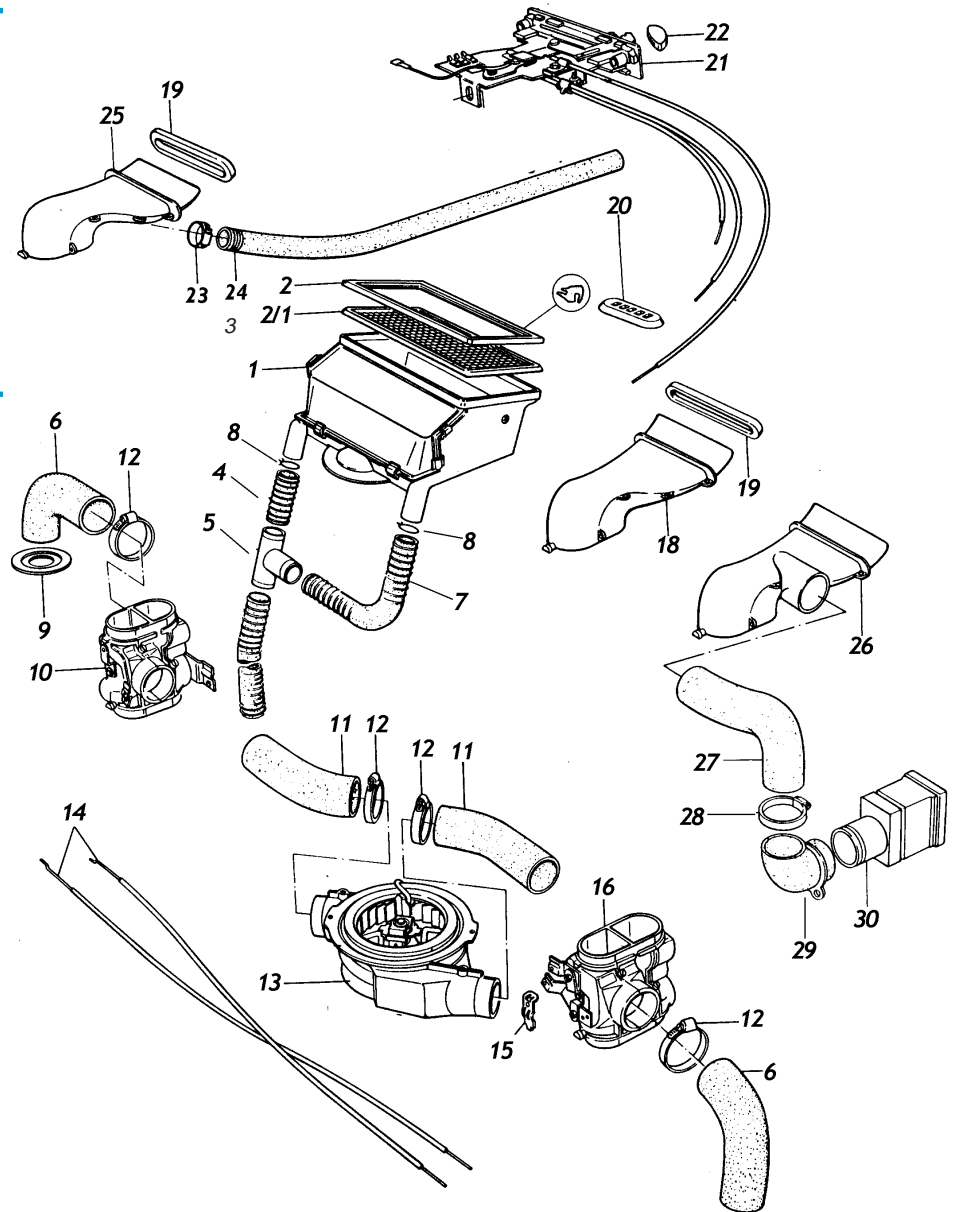

914 & 914-6 Electrical

Description	Part Number	Gen.	Repl.	Used	Rep./Reb.
1 Fresh Air Inlet Box	914 571 907 00	\$410.89	--	\$125.00	--
2 Seal Frame, Up To 1973	914 571 904 10	--	--	--	--
Seal From, From 1973	914 571 129 10	\$134.08	--	--	\$25.00
3 Grill, From 1973	914 571 131 10	\$114.89	--	\$45.00	--
4 Drain Hose, Left	914 571 157 10	\$28.50	--	--	--
5 Connector For Drain Hose	914 571 153 10	\$9.82	--	\$5.00	--
6 Connecting Hose Left Or Right	914 572 123 10	\$25.41	\$18.42	--	--
7 Drain Hose, Right	914 571 156 10	\$21.46	--	\$8.50	--
8 Hose Clamp	999 512 165 02	\$1.73	--	\$1.00	--
9 Seal Ring	914 572 913 10	--	--	\$6.00	--
10 Control Box, Right	914 571 150 10	\$262.21	--	\$71.00	--
11 Connecting Hose	914 571 123 10	\$9.58	--	\$5.00	--
12 Clamp	999 512 319 02	\$4.84	1.73	--	--
13 Bower Housing, Motor & Ventilator	911 571 044 32	\$864.68	\$404.25	\$300.00	--
Seal Ring, Blower Housing To Motor	901 571 922 00	\$6.52	--	--	--
14 Wire Pull	914 571 118 10	\$12.44	--	\$9.00	--
15 Fastening Clamp	901 571 919 00	\$5.83	--	\$2.00	--

Description	Part Number	Gen.	Repl.	Used	Rep./Reb.
16 Control Box, Left	914 571 149 10	\$262.21	--	\$75.00	--
18 Nozzle, Left 1970-71	914 572 045 10	\$43.42	--	\$15.00	--
19 Seal Ring For Nozzle	914 572 157 10	\$7.13	--	--	--
20 Covering For Nozzle, Center 1970-71	914 572 189 10	\$46.70	--	\$15.00	--
21 Control Switch, Lighted	914 613 134 13	\$341.13	--	\$75.00	--
22 Button, Black	901 571 917 00	\$8.30	--	\$2.00	--
Button, Red	901 571 918 00	\$8.80	--	\$2.00	--
23 Clamp	999 512 133 02	\$3.72	\$1.73	--	--
24 Heating Hose	914 572 127 10	\$21.82	\$15.02	--	--
25 Nozzle, Right 1970-71	914 572 046 10	\$46.80	--	\$25.00	--
26 Nozzle, Left 1972-76	914 572 045 11	\$46.33	--	\$25.00	--
Nozzle, Right 1972-76	914 572 046 11	\$49.04	--	\$25.00	--
27 Hose, Left 1972-76	914 572 109 10	\$19.55	\$11.55	--	--
Hose, Right 1972-76	914 572 110 10	\$20.42	\$11.55	--	--
28 Clamp 1972-76	999 512 150 02	--	\$2.50	--	--
29 Elbow	914 572 265 10	\$7.88	--	\$5.00	--
30 Ventilation Nozzle 1972-76	914 572 039 11	\$40.21	--	\$25.00	--

Quick Reference Guide

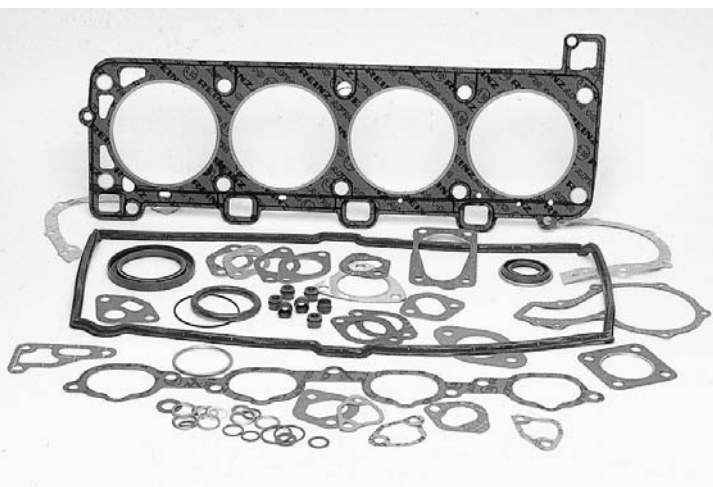

ENGINE & CYLINDER HEAD

CASE STUD O-RING	
Silicone.....	R999 701 006 40.....\$1.10
CAM PLUG	
1970-76.....	R113 101 157 C.....\$2.42
BREATHER COVER GASKET	
6 cylinder.....	R930 107 791 01.....\$3.80
CYLINDER HEAD, REMANUFACTURED	
Complete, 1.7 liter.....	G022 101 361 AKX.....\$574.75
Complete, 1.7 liter w/rocker chamber vent.....	G022 101 061 DX.....\$755.21
Cylinder head nut 10x15, 914/4 1970-76.....	R021 101 457.....\$2.31
CYLINDER HEAD GASKET	
6 cylinder 80mm.....	R901 104 391.....\$10.39
1.7 liter.....	R021 101 343.....\$4.62
1.8 liter.....	R021 101 343 A.....\$4.62
CAM HOUSING GASKET	
6 cylinder.....	R930 105 197 01.....\$1.64
VALVE COVER GASKET	
4 cylinder.....	R021 101 481.....\$3.50
Intake 6 cylinder.....	R930 105 194 00.....\$9.81
Exhaust, 6 cylinder (silicon coated).....	R930 105 196 98.....\$23.10
Exhaust, 6 cylinder (silicon bead).....	R930 105 195 01.....\$34.65
VALVE COVER	
Lower, 6 cylinder.....	R930 105 116 00.....\$90.42
Upper, 6 cylinder.....	R901 105 115 03.....\$286.00
VALVE COVER NUT	
8mm, 6 cylinder.....	GN113081.....\$1.21
TIMING CHAIN HOUSING	
6 cylinder, L/H.....	R930 105 061 01.....\$240.24
6 cylinder, R/H.....	R930 105 062 01.....\$625.00
TIMING COVER GASKET	
6 cylinder chain housing to case.....	R930 105 193 05.....\$1.46

ENGINE GASKET SETS

COMPLETE GASKET SET	
1.7 liter.....	R021 198 009 B.....\$76.99
1.8 liter.....	R021 198 009 C.....\$76.99
1.8 liter.....	R029 198 009.....\$57.75
2.0 liter 4 cyl.....	R039 198 009.....\$76.99
6 cylinder.....	R901 100 902 03.....\$325.71

CRANKSHAFT, BEARINGS & FLYWHEEL

CRANK/MAIN DOWEL PIN	
Crankcase jointing faces (8x25).....	G113 101 111.....\$1.00
FRONT CRANK SEAL	
6 cylinder at pulley.....	R999 113 290 41.....\$8.23
4 cylinder.....	R021 105 247 A.....\$7.90
REAR CRANK SEAL	
4 cylinder.....	R029 105 245 B.....\$15.95
6 cylinder, 65x85x10mm.....	R999 113 057 52.....\$17.60
TIMING GEAR, CRANK	
Drives cam, 4 cylinder.....	G021 105 209 A.....\$98.48
Drives distributor 4 cylinder.....	G901 102 115 00.....\$109.18
WOODRUFF KEY	
914/4, 1970-76.....	G111 105 213.....\$8.32
FLYWHEEL, NEW	
4 cylinder.....	R022 105 273 A.....\$290.20
6 cylinder.....	R901 102 026 01.....\$395.00
Flywheel Bolt.....	R911 102 171 00.....\$9.75
FLYWHEEL GASKET/O-RING	
Washer.....	R021 105 275.....\$3.50
"O"-Ring, 4 cyl.....	R021 105 279.....\$2.20
CRANK END-PLAY SHIM	
914/4, 1970-76 (.30mm).....	G021 105 281.....\$4.49
914/4, 1970-76 (.32mm).....	R021 105 283.....\$4.60
914/4, 1970-76 (.34mm).....	R021 105 285.....\$4.94
914/4, 1970-76 (.36mm).....	R021 105 287.....\$4.62
914/4, 1970-76 (.38mm).....	R021 105 289.....\$4.62
914/7, 1970-76 (.40mm).....	G021 105 291.....\$3.23
CONNECTING ROD, NEW	
2.0 liter, 4 cylinder.....	G039 105 401.....\$181.50
CONNECTING ROD, REMANUFACTURED	
1.7, 1.8 liter.....	G021 105 401 AX.....\$60.50
CONNECTING ROD BOLT	
6 cylinder.....	R901 103 172 00.....\$10.50
CONNECTING ROD NUT	
4 cylinder.....	G113 105 427.....\$4.75
6 cylinder.....	R901 103 173 00.....\$2.14
CONNECTING ROD BUSHING	
4 cylinder.....	R021 105 431 A.....\$13.20
MAIN BEARING SET	
4 cylinder, standard.....	R021 198 481 A.....\$60.70
6 cylinder, standard.....	G911 101 901 00.....\$427.39
6 cylinder, #8 standard.....	R901 101 138 03.....\$60.45
4 cylinder .25mm (.010") O/S.....	R021 198 483 A.....\$87.94
6 cylinder .25mm (.010") O/S.....	G901 101 131 50.....\$45.96
4 cylinder .50mm (.020") O/S.....	R021 198 485 A.....\$75.07
6 cylinder .50mm (.020") O/S.....	R911 101 901 55.....\$114.35
4 cylinder .75mm (.030") O/S.....	G021 198 487 A.....\$58.43
4 cylinder .50mm (.020") case standard crank & thrust.....	R021 198 482.....\$95.84
.50mm (.020") case .25mm (.010") crank standard thrust, 4 cylinder.....	R021 198 484 OR.....\$105.19
.50mm (.020") case .75mm (.030") crank standard thrust, 4 cylinder.....	R021 198 488 OR.....\$105.19
4 cyl, (.020") case .75mm (.030") crank 1.0mm (.040") thrust.....	G021 198 488 TOR.....\$72.60

CRANKSHAFT, BEARINGS & FLYWHEEL

ROD BEARING SET

Standard, 1.7 & 1.8	R021 105 701 A	\$29.95
.25mm (.010") O/S 1.7 & 1.8	R021 105 707 A	\$32.34
.50mm (.020") O/S 1.7 & 1.8	R021 105 713 A	\$43.89
.75mm (.030") O/S 1.7 & 1.8	R021 105 719 A	\$63.52
1.0mm (.040") O/S 1.7 & 1.8	G021 105 725 AOR	\$33.88
Standard 2.0.....	R039 105 701	\$40.42
.25mm (.010) O/S 2.0.....	R039 105 707	\$50.42
.50mm (.020") O/S 2.0	R039 105 713	\$43.89
.75mm (.030") O/S 2.0	R039 105 719	\$63.53
Standard 6 cylinder.....	R901 103 141 00	\$69.98
.25mm (.010") O/S 6 cyl.....	R901 103 141 50	\$43.45
.50MM (.020") O/S 6 cyl.....	R901 103 141 60	\$24.75



PISTONS & RINGS

PISTON & LINER KITS

1.7 except Cal 1973 90mm, German (doamed)	R022 198 075	\$571.73
1973 Cal 1.7, 90mm German (dished).....	R021 198 075 B	\$654.89
1.7 big bore, 96mm	R022 198 075 A 96	\$495.00
1974-76, 1.8 93mm (dished), German	R022 198 075 A 93	\$777.32
1973-76, 2.0, 94mm US models	R039 198 075 A 96	\$850.00
1973-76, 2.0 94mm European models.....	R039 198 075	\$850.00
6 cylinder, Mahle.....	R901 103 903 01	\$2,552.25

PISTON RING SET

Standard 6 cylinder	G901 103 901 00.....	\$54.65
Standard 1.7 liter.....	R021 198 175	\$69.24
Standard 1.8 liter.....	R021 198 175 A	\$79.11
Standard 1.7 liter 96mm big bore.....	R021 198 175 96.....	\$78.65
Standard 2.0 liter.....	R039 198 175 A	\$75.07

PISTON PIN

24x72mm	G021 107 411 A	\$17.12
24x78mm	G022 107 411 A	\$39.04

VALVE TRAIN

CAMSHAFT

4 cylinder.....	R021 109 021 M	\$282.98
-----------------	----------------------	----------

CAMSHAFT SEAL

6 cylinder.....	R999 113 068 50.....	\$12.71
-----------------	----------------------	---------

CAM FOLLOWER

4 cylinder.....	R021 109 309 G	\$16.10
-----------------	----------------------	---------

CAM BEARING SET

4 cylinder.....	R021 198 541	\$21.53
-----------------	--------------------	---------

TIMING GEAR, CAM

6 cylinder.....	R901 105 546 02.....	\$80.85
-----------------	----------------------	---------

VALVE TRAIN

INTERMEDIATE SHAFT

Size 0	R993 105 013 01.....	\$462.00
Size + 1	R993 105 013 11.....	\$462.00

INTERMEDIATE SHAFT BEARING

6 cylinder, front 2 req'd.....	R993 101 135 00.....	\$16.10
6 cylinder, thrust, 2 req'd.....	R993 101 137 00.....	\$15.01

TIMING GEAR COUNTERSHAFT

Chain sprocket 6 cylinder.....	R901 105 125 04.....	\$35.04
Size 0, 6 cylinder.....	R930 105 136 00.....	\$138.00
Size + 1, 6 cylinder.....	G930 105 136 01.....	\$143.99

TIMING CHAIN

6 cylinder w/o master link.....	R911 105 529 00.....	\$40.42
6 cylinder, w/master link.....	R911 105 529 50.....	\$34.10

TIMING CHAIN GUIDE

6 cylinder 1 required on R/H	R911 105 222 05.....	\$6.00
6 cylinder, (black), 3 req. on L/H & 2 req. on R/H	R911 105 222 06.....	\$4.40

CHAIN TENSIONER

6 cylinder.....	G930 105 049	\$151.94
6 cylinder, mechanical.....	G930 105 050 00.....	\$60.50

CHAIN TENS SPROCKET

6 cylinder.....	G901 105 055 00.....	\$84.83
-----------------	----------------------	---------

PUSH ROD

4 cylinder.....	G021 109 301 A	\$37.51
-----------------	----------------------	---------

PUSH ROD TUBE SEAL

Inner.....	G021 109 345 A	\$3.59
Outer.....	G021 109 349 B	\$3.40

ROCKER ARM SHAFT

Genuine.....	R901 105 342 04.....	\$13.86
--------------	----------------------	---------

ROCKER ARM

6 cylinder, genuine.....	R930 105 043 00	\$28.87
Rocker arm busing.....	G901 105 043 98	\$4.84

VALVE ADJUSTER/SHIM

Screw, 4 cylinder, 1970-73, 1.7.....	R022 109 451	\$3.46
Screw, 4 cylinder, 1973, 2.0	G039 109 451	\$26.74
Screw, 4 cylinder, 1974-76 1.8/2.0.....	R043 109 451	\$2.70
Screw, 6 cylinder.....	R901 105 370 02.....	\$9.35
Lock nut.....	R999 034 005 00.....	\$1.16
Rocker shaft nut 6 cylinder.....	R901 105 376 02.....	\$5.48

INT/EXH VALVE GUIDE SILICONE BRONZE

Intake	R021 101 403 A	\$5.78
Exhaust 1.7/1.8 liter	R021 101 417 A	\$3.50
Exhaust 2.0 liter	R039 101 421	\$10.95
6 cylinder.....	R930 104 321 50.....	\$9.20

INTAKE VALVE

1970-75, 1.7 liter	R021 109 601	\$20.70
1970-75, 1.8 liter	R022 109 601	\$22.74
1973-76, 2.0 liter	R039 109 601 G	\$47.90
6 cylinder.....	R901 105 407 00.....	\$36.90

Quick Reference Guide

VALVE TRAIN

EXHAUST VALVE

1.7 liter	R022 109 612 D	\$32.34
1.8 liter	R022 109 612 A	\$44.47
2.0 liter	R039 109 611 L	\$69.50
6 cylinder	R901 105 408	\$93.55

VALVE SPRING

4 cylinder	R021 109 623 E	\$9.84
6 cylinder inner and outer	R901 105 901 50	\$19.50

UPPER SPRING SEAT

6 cylinder	G901 105 421 03	\$6.03
------------------	-----------------------	--------

LOWER SPRING SEAT

6 cylinder	G901 105 463 00	\$10.97
------------------	-----------------------	---------

VALVE KEEPER

4 cylinder	R113 109 651 A	\$2.30
6 cylinder	R901 105 417 00	\$1.00

VALVE STEM SEAL

6 cylinder	R928 104 193 12	\$5.50
------------------	-----------------------	--------



OIL FILTER & OIL SYSTEM

OIL FILTER

4 cylinder	R021 115 351 A	\$10.79
6 cylinder	R901 107 203 09	\$14.43

OIL STRAINER GASKET SET

4 cylinder	R021 198 031B	\$4.04
------------------	---------------------	--------

OIL RETURN TUBE

4 cylinder	R021 109 335 C	\$9.00
6 cylinder	R901 107 351 01	\$16.23
6 cylinder complete w/seals	R930 107 040 01	\$34.10

OIL RETURN TUBE SEAL

O-Ring, 6 cylinder	G999 701 112 40	\$2.42
--------------------------	-----------------------	--------

OIL PUMP

4 cylinder	G021 115 107 AK	\$72.60
4 cylinder oil pump body (OEM)	G021 115 107 A	\$272.32
6 cylinder MUST USE CONV. KIT 91110700805K		
.....	R911 107 008 05	\$795.00
CONV KIT to adapt 91110700805 pump, 6 cylinder	G911 107 008 05 K	\$71.39

OIL PUMP DRIVE GEAR

4 cylinder	G021 115 123	\$11.97
W/shaft, 4 cylinder	G021 115 115 A	\$21.04

OIL FILTER & OIL SYSTEM

OIL PUMP GASKET

4 cylinder	R021 198 031 B	\$4.04
6 cylinder	R930 101 391 00	\$4.00

OIL STRAINER

6 cylinder	R930 107 314 00	\$86.82
------------------	-----------------------	---------

OIL FILLER CAP GASKET

Lower, for 1.8 liter	R022 115 315	\$5.00
Upper, for 1.8 liter	R022 115 331	\$9.69

OIL GALLEY PLUG

6 cylinder, 1970-71	R911 107 176 03	\$10.40
---------------------------	-----------------------	---------

OIL COOLING SYSTEM

OIL COOLER

4 cylinder, remanufactured	R021 117 021 B	\$155.92
Seal, 4 cylinder	R021 117 151 A	\$2.88

OIL HOSES & LINES

6 cylinder, oil line cam housing L/H	R901 107 347 01	\$16.75
6 cylinder, oil line cam housing R/H	R901 107 348 00	\$18.10
6 cylinder, oil hose air cleaner to tank	R901 107 394 02	\$65.00

COOLING SYSTEM

THERMOSTAT

4 cylinder	R021 119 159 A	\$82.00
------------------	----------------------	---------

FUEL FILTER & FUEL SYSTEM

FUEL FILTER

1971-74, Kaiser	R311 133 511 D	\$17.71
1971-74, Bosch	R71 012	\$16.17
1970 & 1975-76, Bosch	R113 133 511	\$17.60
1970 & 1975-76, Kaiser	R133 133 511	\$13.00

MECHANICAL FUEL PUMP

1974-76, 1.8	G021 127 025 A	\$114.77
--------------------	----------------------	----------

ELECTRIC FUEL PUMP

Thru 1974, 4 cylinder	R311 906 091 D	\$428.20
From 1975, 4 cylinder 1795cc & 1970cc	G251 906 091	\$240.47
6 cylinder	R911 608 107 00	\$463.84

FUEL PUMP RELAY, 1.8 LITER

0 332 514 120	R022 906 059	\$83.16
---------------------	--------------------	---------

CARBURETOR BASE GASKET

6 cylinder	R901 108 398 01	\$4.59
------------------	-----------------------	--------

CARBURETOR REPAIR KIT

6 cylinder	R911 108 948 00	\$76.95
------------------	-----------------------	---------



FUEL FILTER & FUEL SYSTEM

FUEL INJECTOR

1.7 liter	B022906031A.....	\$47.00
1.8 liter	G0 280 150 112.....	\$76.23
Through 1974, 2.0 liter 4 cylinder.....	R039 906 031.....	\$155.00
From 1975, 2.0 liter.....	B039 906 031A.....	\$75.00

REMANUFACTURED GAS FUEL INJECTOR

914/4, 1800cc exchange.....	G380116.....	\$43.56
1973-76, 914/4 exchange	G380038.....	\$42.35
1970-72, 1700cc exchange.....	B380009.....	\$64.05

FUEL INJECTOR SEAL

4 cylinder, small	R311 133 261 A.....	\$1.16
4 cylinder, large.....	R311 133 263.....	\$1.16

INJECTOR CONTR UNIT/BRAIN

1970-72, 1.7 liter Bosch	GCU11X.....	\$332.75
1973 2.0 liter Bosch	GCU13X.....	\$356.95
1974 1.8 liter Bosch	GCU14X.....	\$363.00
1975 1.8 liter Bosch	GCU66X.....	\$375.10
1975-76 2.9 liter Bosch	GCU16X.....	\$332.75

REMANUFACTURED AIR FLOW METER

1974, 914/4 exchange.....	B022 906 301.....	\$181.00
1975 914/4.....	R473 906 301.....	\$489.00

COLD START VALVE

1.7 liter	G0 280 170 017.....	\$54.45
1.8 liter	G0 280 170 026.....	\$49.61
2.0 liter, 4 cylinder.....	G0 280 170 015.....	\$60.50

VACUUM LIMITER

1970-72, 1.7 liter/1974 1.8 liter	R0 280 160 102.....	\$86.63
1975 1.8 liter	G0 280 160 300.....	\$98.01
1973-76 2.0 liter	G0 280 160 108.....	\$90.75

THROTTLE SWITCH

1.7 liter 1970-71	R0 280 120 042.....	\$83.74
1.7 liter 1972-73 0 280 120 021	R022 906 111 B.....	\$145.00
1.8 liter 1974-76 0 280 120 201	R022 906 111 D.....	\$77.56
2.0 liter 1973-76	G039 906 111 A.....	\$354.00

PRESSURE SENSOR

1970-72 0 280 100 049.....	B022 906 051 E.....	\$275.00
1973-76 0 280 100 043.....	B039 906 051.....	\$275.00
1970-72, 1.7 liter rebuilt	B210049.....	\$114.95
1973-1976 2.0 liter rebuilt exchange.....	B039 906 051.....	\$275.00

FUEL PRESS REGULATOR

1.7 & 2.0 liter	G0 280 160 001.....	\$48.40
1.8 liter	R0 280 160 200.....	\$92.40

CYLINDER HEAD TEMP SENSOR

1970*76 1.7 liter & 1.8 liter 1974076 2.0	R311 906 041.....	\$30.20
1973 2.0 0 280 130 017.....	R022 906 041 A.....	\$32.94

THERMO TIME SWITCH

1.8 liter	R928 605 101 00.....	\$51.98
2.0 liter	G0 280 130 205.....	\$164.56
Auxiliary air regulator 1.8	G0 280 140 101.....	\$90.75
Supply 0 280 141 011.....	G928 606 215 01.....	\$116.06
Auxiliary air regulator 1.7, 2.0 exch.....	B022 906 045.....	\$159.00

AIR BOX

1974, 1.8 liter	G0 280 200 001.....	\$296.45
1975-76 1.8 liter	R0 280 201 002.....	\$358.05

INJECTOR TRIGGER POINTS

Except 1.8.....	R311 905 301.....	\$155.05
-----------------	-------------------	----------

AIR FILTER & INTAKE SYSTEM

AIR FILTER

1.7 liter	R022 129 620.....	\$14.43
1.8 & 2.0 liter 4 cylinder.....	R039 129 620 A.....	\$12.00
6 cylinder.....	R901 108 955 11.....	\$23.00

AIR INTAKE BOOT

'70-'73 914/4 1.7 liter conn. hose to cyl. pipe.....	R022 133 241 B.....	\$7.50
'73-'76, 914/4 1.8 & 2.0 liter conn. hose to cyl. pipe	R039 133 241.....	\$7.50

INTAKE MANIFOLD GASKET

4 cylinder 1.7 & 1.8	R022 129 707 F.....	\$11.55
4 cylinder 2.0.....	R039 129 707.....	\$13.00
6 cylinder.....	R901 108 391 01.....	\$4.59

EMISSION CONTROL COMPONENTS

AIR PUMP FILTER

2.0 liter	R113 131 123.....	\$19.31
-----------------	-------------------	---------

FUEL TANK & COMPONENTS

fuel tank screen.....	R111 209 147 A.....	\$8.45
gas cap, through 1973	B343 201 551.....	\$19.50

CLUTCH COMPONENTS

CLUTCH COVER

215mm	R901 116 001 01.....	\$172.95
-------------	----------------------	----------

CLUTCH DISC

215mm	RPCG 116 011 05.....	\$155.92
Throwout bearing.....	R901 116 081 11.....	\$109.30

PILOT SHAFT BEARING

914/4, for gland nut	R111 105 313 A.....	\$5.77
914/6, 1970-71.....	R901 102 025 01.....	\$16.44



ENGINE MOUNTS

ENGINE MOUNT

4 cylinder, 1973-76.....	R039 199 231.....	\$23.83
4 cylinder, 1970-72.....	B914 375 025 00.....	\$45.00

Quick Reference Guide

TRANSMISSION MOUNTS

TRANSMISSION MOUNT

From 1973..... B914 375 025 00.....\$45.00

EXHAUST SYSTEM

MUFFLER

Thru 1974, 1.7, 1.8 w/o E.G.R. valve.....R021 251 053 C.....\$375.00
 Thru 1974, 1.7, 1.8 w/E.G.R. valve.....G021 251 053 F.....\$363.00
 1973-74, 2.0.....R039 251 051 D.....\$545.00
 Front 1975-76 1.8 2.0.....R039 251 053.....\$695.00
 Rear 1975-76 1.8, 2.0.....R039 251 055 A.....\$431.00
 6 cylinder.....R901 111 011 11.....\$675.50

CONNECTING PIPE

4 cylinder, center.....R039 251 058.....\$40.90

TAIL PIPE

W/orig.rear panel (770mm) 1970-71, 1.7, 1.8.....R021 251 171 M.....\$57.70
 W/modif. rear panel (660MM) 1972-73, 1.7.....B021 251 171 N.....\$55.00
 1975-76 1.8.....R021 251 185 C.....\$33.49

EXHAUST FLANGE GASKET

1970-74, 1.7 1.8.....R025 251 261.....\$5.48
 1973-74, 2.0.....R039 251 261.....\$5.19
 1975-76, 1.8 2.0 at muffler flange.....R443 253 115 B.....\$5.19
 6 cylinder, at muffler.....R901 111 193 00.....\$8.74
 6 cylinder, cylinder head to heat exchanger.....R930 111 191 11.....\$8.09

EXHAUST MANIFOLD COPPER O-RING

1.7 liter.....R021 256 251 A.....\$2.30
 1.8/2.0 liter.....R039 256 251.....\$2.30
 6 cylinder.....R930 111 191 11.....\$8.09

EXHAUST NUT

Copper, 8x12 mm.....GN11 00 812.....\$2.42
 Copper, 8x13mm.....GN11 00 813.....\$2.42

HEAT CONTROL VALVE

L/H.....R022 256 205 B.....\$120.00
 R/H.....R022 256 206 A.....\$120.00

EXHAUST SYSTEM MOUNTING KIT

For muffler thru 1974, 1.7/1.8.....G411 298 009.....\$10.89
 For tail pipe thru 1974, 1.7/1.8.....R411 298 051.....\$5.78



MANUAL TRANSMISSION

Shift lever seal.....R001 301 227.....\$5.20

MAINSHAFT SEAL

German.....R113 311 113 A.....\$10.60

MAINSHAFT BEARING

Front.....G999 053 025 00.....\$259.87
 Rear.....R999 110 014 00.....\$379.50

SYNCHRONIZER RING

All gears.....R911 302 301 06.....\$62.00

CLUTCH GEAR SLIDER

2nd-5th gear.....R911 302 411 10.....\$170.85
 1st & reverse gear.....R911 302 226 00.....\$415.00
 Speedo drive gear.....R914 318 029 01.....\$66.00

GEAR SET, 1ST

With double reserve.....R911 302 903 00.....\$127.00

GEAR TEETH

1st gear.....R901 302 241 06.....\$120.62
 2nd-5th gear.....R901 302 242 03.....\$135.61
 M/T gasket set.....R914 300 901 00.....\$57.75

DIFFERENTIAL

LOCK RING, JOINT FLANGE

4 cylinder.....G113 517 279.....\$1.00

PINION SHAFT BEARING

Front in intermediate plate.....R999 052 016 00.....\$150.10
 Rear.....G999 110 013 00.....\$228.39
 Differential side bearing.....G999 059 008 00.....\$110.28

FINAL DRIVE SEAL

6 cylinder, 45x65x10mm.....G999 113 058 50.....\$18.92
 Final drive cover o-ring.....R113 301 185 A.....\$4.62

FRONT BRAKE & HYDRAULICS

FRONT BRAKE ROTOR

1970-mid 1972 4 cylinder thru CH.# 4722919032
R411 407 075.....\$60.00
 Mid 1972-76, 4 cylinder from CH.# 4722919033
R411 407 075 B.....\$65.94
 6 cylinder.....R901 351 401 10.....\$75.00

FRONT BRAKE PADS

6 cylinder, all 4 cylinder, thru ch# 4722919032
GD195.....\$30.25
 6 cylinder, all 4 cylinder, thru ch# 472291033
GD195T.....\$90.75
 4 cylinder, from ch# 4722919033.....RD196M.....\$36.30

FRONT CALIPER

Thru mid 1972, L/H thru CH #4722919032
B411 615 107 OR.....\$170.00
 Thru mid 1972, R/H thru CH #4722919032
B411 615 108 OR.....\$181.00
 From mid 1972, L/H from CH #4722919033
B914 351 425 00.....\$181.50
 From mid 1972, R/H from CH #4722919033
B914 351 426 00.....\$181.50

FRONT CALIPER KIT

4 cylinder thru # 4722919032.....R411 698 471.....\$29.64
 4 cylinder from # 4722919033.....R411 698 471 A.....\$21.95
 6 cylinder.....R901 351 964 11.....\$20.30

FRONT BRAKE HOSE

Thru 1971.....R901 355 632 01.....\$20.84
 From 1972.....R281 611 775 B.....\$16.75

FRONT BEARINGS & SEALS

FRONT INNER WHEEL BEARING

4 cylinder, roller.....	R311 405 625 B	\$10.40
6 cylinder, roller.....	R211 405 625	\$11.55

FRONT OUTER WHEEL BEARING

4 cylinder, roller.....	R311 405 645	\$9.63
6 cylinder, roller.....	R211 405 645 D	\$10.99

FRONT AXLE SEAL

4 cylinder	R321 501 641	\$6.93
6 cylinder	R477 405 641	\$5.95

FRONT AXLE NUT

4 cylinder, L/H.....	G131 405 669	\$29.00
4 cylinder, R/H.....	G131 405 670	\$25.56



STEERING & SUSPENSION

Rack & pinion assembly.....	G914 347 010 06.....	\$961.32
-----------------------------	----------------------	----------

BALL JOINT

Thru mid 1972 double key.....	G901 641 049 00.....	\$61.71
From mid 1972 clamping slash	R911 341 049 01	\$54.46
Tie rod.....	R911 347 031 00.....	\$67.00

REAR BRAKE & HYDRAULICS

REAR BRAKE ROTOR

4 cylinder	R914 352 401 10.....	\$73.18
6 cylinder	R901 352 401 18.....	\$105.00

REAR BRAKE PADS

4 cylinder	RD204A.....	\$90.75
4 cylinder, Taxtar, Jurid.....	GD204T.....	\$82.50
6 cylinder	R914 351 905 00.....	\$40.43

REAR CALIPER

4 cylinder, L/H.....	B914 352 423 00.....	\$181.00
4 cylinder, R/H.....	B914 352 424 00.....	\$181.00
Rear caliper kit.....	R914 352 998	\$34.50
Rear caliper rebuilt exchange, right (core \$100).....	B914 352 424 00.....	\$181.00
Rear caliper rebuilt exchange, left (core \$100).....	B914 352 423 00.....	\$181.00
Rear brake hose.....	R901 355 631 01.....	\$16.75

REAR BEARING & SEALS

Rear wheel bearing.....	R443 407 625	\$52.74
-------------------------	--------------------	---------

REAR C/V AXLES & COMPONENTS

Rear driveshaft.....	B914 332 009 03.....	\$199.60
----------------------	----------------------	----------

REAR C/V JOINT

Inner & outer	G914 332 029 03.....	\$243.07
---------------------	----------------------	----------

REAR C/V JOINT BOOT

4 cylinder.....	R113 501 149	\$11.55
6 cylinder.....	R901 332 293 10.....	\$8.80

REAR C/V BOOT CLAMP

59mm	R113 501 157.....	\$1.16
------------	-------------------	--------

REAR C/V JOINT BOLT

4 cylinder.....	R113 501 229	\$2.30
Flange stretch bolt 6 cyl holds flange to differential	G901 332 275 11	\$15.36
Rear C/V joint gasket	R914 332 237 01	\$2.20

STRUTS & SHOCK ABSORBERS

FRONT STRUT INSERT

4 cylinder	R914 341 903 00.....	\$89.50
6 cylinder	R911 341 913 03.....	\$84.32

KYB FRONT STRUT INSERT

From 1971.....	R361004	\$114.40
----------------	---------------	----------

REAR SHOCK ABSORBER

4 cylinder	R914 333 051 01.....	\$90.00
6 cylinder	G901 333 051 02.....	\$281.46
KYB rear shock Gas-a-Just.....	RKG9003.....	\$80.25

ROAD WHEEL

LUG NUT

Nut, 6 cylinder	R999 182 003 36.....	\$8.25/Each
Bolt, 4 cylinder alloy	B914 361 315 01.....	\$11.00/Each
Bolt, 4 cylinder standard.....	G281 601 139.....	\$8.97

HUB CAP

67mm, 6 cylinder, alloy wheel, silver.....	B901 361 032 00.....	\$28.29
--	----------------------	---------



ORDER ONLINE!

Porsche parts at www.AutoAtlanta.com

Wholesale parts for all makes and models at www.AutomobileAtlanta.com

G = Genuine • R = Aftermarket / Replacement •
U = Used • B = Rebuilt or Reproduction

Quick Reference Guide

MASTER BRAKE HYDRAULICS

BRAKE MASTER CYLINDER		
4 cylinder.....	R914 355 012 00.....	\$192.40
6 cylinder.....	R911 355 012 02.....	\$185.00
BRAKE MASTER CYLINDER KIT		
4 cylinder.....	G914 355 908 00.....	\$78.41
6 cylinder.....	R901 355 930 00.....	\$56.75

SHIFT LINKAGE & COMPONENTS

SHIFT LEVER BOOT		
Thru 1972.....	G914 424 901 00.....	\$56.36
Shift coupler bushing.....	R914 423 211 00.....	\$2.30
Shift rod support bushing.....	R914 424 224 00.....	\$13.70



CABLES, PEDALS & COMPONENTS

Hand brake lever 1973-76.....	R914 424 053 01.....	Call
HAND BRAKE CABLE		
L/H.....	R914 424 551 01.....	\$51.97
R/H.....	R914 424 552 01.....	\$51.97
PEDAL PAD		
Brake & clutch.....	R914 423 210 00.....	\$5.20
Accelerator pedal.....	R901 423 010 00.....	\$59.50
CLUTCH CABLE		
4 cylinder.....	R914 423 401 05.....	\$22.50
6 cylinder.....	R914 423 401 02.....	\$25.25
Clutch cable wedge.....	R911 423 205 03.....	\$16.44
CLUTCH CABLE		
Boot.....	R914 423 922 02.....	\$9.24
Clutch cable clevis pin.....	R999 166 001 02.....	\$6.93
Pedal bushing kit.....	G911 423 542 98.....	\$24.20
ACCELERATOR CABLE		
4 cylinder.....	R914 423 067 02.....	\$24.58
Hood release cable.....	G914 511 091 10.....	\$28.01
Speedometer cable.....	R914 641 111 00.....	\$55.00

BUMPERS & COMPONENTS

FRONT BUMPER PAD		
Thru 1974.....	R914 503 023 10.....	\$415.95
FRONT BUMPER GUARD		
Thru 1974, L/H.....	R914 505 063 10.....	\$137.00
Thru 1974, R/H.....	R914 505 064 10.....	\$144.38
Front bumper bracket.....	G914 505 027 10.....	\$42.71

BUMPERS & COMPONENTS

REAR BUMPER PAD		
Thru 1974.....	R914 503 027 10.....	\$340.73
1975-1976 (cover).....	R914 503 233 10.....	\$669.90
REAR BUMPER GUARD		
Thru 1974, L/H.....	R914 505 085 10.....	\$144.38
Thru 1974, R/H.....	R914 505 086 10.....	\$144.38
From 1975, R/H.....	G914 505 191 10.....	\$65.28
From 1975, R/H.....	G914 505 192 10.....	\$67.57

FENDERS, HOODS & REAR LID

Hood hinge.....	R914 501 030 10.....	\$54.65
Hood emblem seal.....	R901 559 215 20.....	\$3.58
HOOD SEAL		
Front at front hood.....	B914 511 901 10.....	\$59.50
Rear at front compartment.....	R914 511 902 10.....	\$80.27
WEATHERSTRIP, REAR LID		
3 sides.....	R914 512 317 10.....	\$72.18
Across front.....	R914 512 315 10.....	\$69.00
Seal, engine compartment.....	R914 504 155 10.....	\$36.80
Cover, front.....	B914 504 105 10.....	\$13.20
SEAL, ENGINE COMPARTMENT		
Cover, front.....	B914 504 105 10.....	\$13.20
Cover, rear.....	R914 504 111 10.....	\$16.10

DOORS & COMPONENTS

Front door strap.....	B914 531 037 10.....	\$98.95
FRONT DOOR HANDLE		
L/H, w/keys.....	R914 531 905 00.....	\$185.95
R/H, w/keys.....	R914 531 906 00.....	\$185.95
Front window handle, 1970-72.....	R113 837 581 D.....	\$32.00
Front window handle, 1973-74.....	G113 837 581 01.....	\$9.08
Front window handle, 1975-76.....	R113 837 581.....	\$9.24
FRONT WINDOW SLOT SEAL		
Outer, L/H squeegee.....	R914 531 873 10.....	\$9.82
Outer, R/H squeegee.....	R914 531 874 10.....	\$9.82
Inner squeegee.....	R914 531 939 10.....	\$17.32
FRONT WINDOW CHANNEL		
Front, at guide divider bar, 1973-76.....	R914 542 161 12.....	\$28.60
Rear, at felt guide, 1973-76.....	R914 542 171 14.....	\$29.64
VENT GLASS SEAL		
L/H.....	G914 542 325 10.....	\$119.39
R/H.....	G914 542 326 10.....	\$110.39
WEATHERSTRIP, FRONT DOOR		
Outer, L/H, on door.....	R914 531 813 10.....	\$98.17
Outer, R/H, on door.....	R914 531 814 10.....	\$98.18
Inner, L/H, on body.....	R914 531 821 10.....	\$68.14
Inner, R/H, on body.....	R914 531 822 10.....	\$68.14

GLASS & SEALS

Dashboard seal to windshield.....	B914 552 263 10.....	\$39.50
REAR WINDOW SEAL		
Rear window to engine lid.....	B914 512 319 10.....	\$39.00
WINDSHIELD SEAL		
Lower at visors.....	R914 563 319 10.....	\$93.50

EXTERIOR TRIM & MOULDING

WINDSHIELD MOULDING

Clip.....	G914 541 921 11.....	\$1.54
Hood emblem.....	R901 559 210 20.....	\$33.75
Hood emblem gasket.....	R901 559 215 20.....	\$3.58
Rocker panel plug.....	B914 559 155 10.....	\$2.20

MIRROR & INTERIOR TRIM

EXTERIOR MIRROR

L/H.....	R914 731 039 10.....	\$192.50
Base.....	B914 731 116 10.....	\$4.95

INTERIOR MIRROR

Adhesive pad.....	R901 731 133 20.....	\$4.82
-------------------	----------------------	--------

SUNROOF, TARGA & CABRIO SEALS

SEAL REMOVABLE TOP

L/H, between top & door glass.....	R914 531 185 10.....	\$63.52
R/H, between top & door glass.....	R914 531 186 10.....	\$63.80
Front on windshield frame.....	G914 563 039 10.....	\$375.00
Rear, top on roll bar.....	R914 563 077 11.....	\$297.00
Rear, L/H vert. rollbar.....	R914 531 143 10.....	\$82.78
Rear, R/H vert. rollbar.....	R914 531 144 10.....	\$82.50

LATCH, TARGA TOP

Front.....	G914 563 071 10.....	\$202.06
Rear, L/H.....	G914 563 081 11.....	\$150.73
Rear, R/H.....	G914 563 082 11.....	\$150.73

FAN BELTS

ALTERNATOR/GENERATOR BELT

4 cylinder, 9.5x965mm.....	R021 903 137 A.....	\$7.51
6 cylinder.....	R10X710.....	\$7.51

AIR PUMP BELT

4 cylinder, 9.5x740mm.....	G068 145 271 B.....	\$7.87
----------------------------	---------------------	--------

CHARGING SYSTEM

REBUILT ALTERNATOR

Thru 1974, 4 cylinder.....	BAL75X.....	\$104.75
6 cylinder.....	RAL21X.....	\$340.73

VOLTAGE REGULATOR

Bosch.....	R30 051.....	\$33.50
Bosch (suppressed).....	R30 051.....	\$33.50

IGNITION

IGNITION POINTS

Bosch, 4 cylinder.....	GR01 011.....	\$5.20
Bosch, 6 cylinder.....	R01 026.....	\$6.93
Marelli, 6 cylinder.....	R901 602 932 00.....	\$10.97

IGNITION CONDENSER

1974-75, 1.8 liter Bosch.....	G021 905 295 B.....	\$9.97
1970-75, 1.7/2.0 liter Bosch.....	R311 905 295 C.....	\$9.97

DISTRIBUTOR CAP

4 cylinder, Bosch.....	R113 905 207 C.....	\$7.64
6 cylinder, Bosch.....	R03 014.....	\$15.95

DISTRIBUTOR ROTOR

1970-76, 4 cylinder except 1975 Rev. Limiting.....	R04 030.....	\$25.97
1975, Bosch Standard.....	R04 033.....	\$9.85

IGNITION

SPARK PLUGS

1970-73 1.7 copper wire.....	RW7DC.....	\$2.89
1970-73 1.7 platinum wire.....	RW7DP.....	\$4.95
1974-76 1.8 & 1972-76 2.0.....	RH178 1399.....	\$2.75
1974-75 1.8 & 1973-76 2.0.....	GW7DP.....	\$4.95
914-6.....	R999 170 010 91.....	\$13.86

IGNITION COIL

4 cylinder, Bosch 00012.....	R043 905 115 C.....	\$41.25
6 cylinder, Bosch 00025.....	G911 602 503 00.....	\$42.68

DISTRIBUTOR, NEW

6 cylinder.....	R0 231 159 008.....	\$771.54
-----------------	---------------------	----------

IGNITION WIRE SET

4 cylinder.....	R021 998 031 A.....	\$35.14
4 cylinder NGK.....	GRCX24.....	\$27.23
6 cylinder.....	G09 009.....	\$194.81

BOSCH IGNITION WIRE SET

4 cylinder.....	B021998031A.....	\$35.14
6 cylinder.....	G09 009.....	\$194.81

IGNITION WIRE CONNECTOR

4 cylinder #2 & #4 cyl., 98mm 0 356 100 027.....	B021 035 255 B.....	\$4.95
4 cylinder #1 & #3 cyl., 62mm 0 356 100 014.....	G113 035 255 A.....	\$10.84

IGNITION WIRE CONNECTOR

6 cylinder "L" Type.....	G901 609 309 00.....	\$50.58
--------------------------	----------------------	---------

IGNITION WIRE TERMINAL

Thread-in connector.....	R111 905 427.....	\$3.47
ignition wire boot.....	R311 905 429 A.....	\$3.46
spark plug air seal.....	R111 905 449 A.....	\$3.46

IGNITION WIRE CLIP

3 wire.....	R113 905 451 A.....	\$2.31
-------------	---------------------	--------

DISTRIBUTOR O-RING

4 cylinder.....	R111 905 261.....	\$2.74
-----------------	-------------------	--------

VACUUM ADVANCE

1.7 liter.....	R07 085.....	\$195.76
1974-75 2.0 liter.....	R039 905 271.....	\$193.20
1974 1.8 liter.....	R07 121.....	\$195.76

IGNITION KIT W/POINTS & CONDENSOR

1.8 liter.....	R05 081.....	\$9.82
----------------	--------------	--------

IGNITION SWITCH

1970, 4 cylinder electrical portion.....	R311 905 865 A.....	\$40.42
1971-74, 4 cylinder electrical portion.....	R111 905 865 K.....	\$17.60
1975-76, 4 cylinder electrical portion.....	R111 905 865 L.....	\$21.67
6 cylinder electrical portion.....	R911 613 017 01.....	\$49.95
Key, blank.....	R914 531 903 10.....	\$16.88
Key, blank, red.....	R914 531 903 11.....	\$13.80



Quick Reference Guide

STARTERS

Rebuilt starter (core \$75)	RSR17X	\$155.95
-----------------------------------	--------------	----------

SWITCHES/SENSORS/RELAYS

OIL PRESSURE SWITCH

4 cylinder, Bosch	R35 158	\$8.08
4 cylinder	R021 919 081 B	\$9.50
6 cylinder push-on connector	R911 606 230 00	\$10.40
Cover	B914 612 316 10	\$29.50

RELAY

Fuel injection, power, window, horn, foglight, heat-window, fuel pump, heat, light motor	R911 615 108 01	\$32.45
Various Functions Round 5-Pin (Black)	R911 615 109 01	\$22.49
1974-75 combination relay	G923 615 101 00	\$107.06
Buzzer	G914 615 112 10	\$15.56

HEADLIGHT, BACKUP & LICENSE LIGHT

HEAD LIGHT MOTOR

L/H	G914 624 114 11	\$329.93
R/H	G914 624 113 11	\$364.04

HEADLIGHT RIM

Chrome	G914 631 107 20	\$54.69
Switch, backup light	R914 613 541 02	\$69.75

SWITCH, HEADLIGHT

4 cylinder 70-73	G914 613 414 10	\$531.60
4 cylinder 74-76	G914 613 414 15	\$551.37
Relay, head light	R111 941 583	\$24.14

LICENSE LIGHT

License light assembly 70-74	R914 631 601 00	\$34.05
------------------------------------	-----------------------	---------

TAIL LIGHT & SIDE MARKER

TAIL LIGHT ASSEMBLY

L/H	G914 631 403 14	\$502.59
R/H	G914 631 404 14	\$502.59

TAIL LIGHT LENS

L/H, red	B914 631 939 11	\$125.00
R/H, red	B914 631 940 11	\$125.00
L/H, red/amber	B914 631 949 10	\$125.00
R/H, red/amber	B914 631 950 10	\$125.00

SIDE MARKER ASSEMBLY

L/H	G914 631 405 00	\$77.99
R/H	G914 631 408 00	\$61.56

SIDE MARKER LENS

L/H	R914 631 945 00	\$18.32
R/H	G914 631 946 00	\$73.30

INTERIOR LIGHT

Interior light assembly	R111 947 111 E	\$12.70
DOME LIGHT SWITCH		
Door contact	R175 947 561	\$6.35

TURN SIGNAL/EMERGENCY FLASHER

Turn signal assembly	G914 631 401 11	\$484.78
----------------------------	-----------------------	----------

SEAL, T/S LENS

At lens	B914 631 957 10	\$12.00
Sleeve for wire harness	G914 631 217 10	\$25.78

TURN SIGNAL LENS

U.S. style	R914 631 934 11	\$29.50
European style	R914 631 937 10	\$29.50

TURN SIGNAL RELAY

Thru 1972	R914 618 303 10	\$39.50
From 1973	R914 618 303 11	\$39.50

TURN SIGNAL SWITCH

6 cylinder	G914 613 303 10	\$409.65
1970-71, 4 cylinder thru CH.#4712909638	R914 613 927 12	\$65.98
1971, 4 cylinder from CH.#4712909638	R914 613 306 17	\$670.00
1972-74, 4 cylinder	R914 613 913 14	\$125.00
1975-76, 4 cylinder	R914 613 913 15	\$95.00

WIPER/WASHER

WIPER MOTOR

2 Stage	R914 628 020 13	\$317.62
WW pressure valve	R914 628 433 00	\$5.49

WIPER ARM

L/H, straight	R914 628 313 10	\$40.42
R/H, angular	R914 628 314 10	\$36.38

WIPER BLADE

SWF	G111413	\$10.99
Bosch	R964 628 901 01	\$8.80
Wiper refill	G901 628 391 20	\$4.84

WIPER/WASHER SWITCH

1970-1971	G141 955 517 A	\$48.72
1972-74	R914 613 915 14	\$250.00
1975-76	R914 613 915 15	\$250.00

WASHER PUMP

6 cylinder	R928 628 074 01	\$51.98
------------------	-----------------------	---------

WASHER JET

1974-76 black	R914 628 203 11	\$6.60
1970-73 silver	R914 628 203 10	\$17.32
Thru mid 1974 dual chrome w/o valve	G901 628 741 20	\$13.39

SPEEDOMETER

SPEEDOMETER

1974.5-76, 150mph	B914 641 505 30	\$170.50
Speedometer calbe	R914 641 111 00	\$55.00





We have it all - all of the New Old Stock no one else has, because of our 30+ years in the 914 parts business! 99% of our orders ship the same day or when combined with used, next day.

The Porsche 914 was an automobile built collaboratively by Volkswagen and Porsche from 1969 through 1976. VW/Porsche originally intended it to be sold in four cylinder trim as a Volkswagen, to be the top-spec VW sports car, and in six cylinder trim as a Porsche, to

be Porsche's entry level car, replacing the 912. However, Porsche decided during development that having VW and Porsche models sharing the same

body would be risky for business in the U.S. market, and convinced VW to allow them to sell both versions as Porsches in North America. Volkswagen versions originally came with a fuel-injected 1.7 liter flat-4 engine based on the unit that powered the 411 and 412 saloon cars, although 1.8 and 2.0 liter engines became available as time went on. Porsche's 914/6 variant came with a carburetted 2.0 liter flat six cylinder engine, taken from the 911T. VW manufactured the rolling chassis at their own plant, then either sent them to Porsche for fitment of the Porsche suspension and flat-six engine or kept them in house for their own hardware. Karmann manufactured the bodies, including the targa-top system. Porsche handled export to the U.S., where both versions were badged and sold as Porsches. Many enthusiasts regard this as having been a big mistake on Porsche's part. 914 production ended in 1976, two years prior to the introduction of its eventual replacement, the 924. Porsche reused the 912, in an updated form called 912E, to fill the gap.

MODEL HISTORY

The 914 was Motor Trend's Import Car of the Year for 1970.

A supercar version known as the Porsche 916 was planned for production in the mid-70's, but was cancelled after the production of only 11 prototypes. These can be easily recognized by their flared fenders and more aggressive front ends when compared to the 914.

Two "special edition" 914s, dubbed 914/8, were built during 1969. The first, a silver unit, was built to commemorate "Ferry" Porsche's 60th birthday, and was powered by a carbureted and de-tuned 908 race motor making 260 hp (194 kW). The second, a red unit powered by the full-blown, 400 horsepower (298 kW) 908 motor was presented to Ferdinand Piech, Ferry's son-in-law and then chairman of the Volkswagen group. The 914/8 bodywork differed from that of the standard 914 in only a few small but noticeable ways. Wheel arches were flared out, larger wheels were fit, and a cooling aperture for the oil cooler was affixed to the front bumper.

The chassis remained largely unchanged, although retuned shocks and custom coil springs cut from titanium were added to the package along with the upgraded bodywork, larger wheels and tires and uprated brakes. The 914/8 was not considered for production as a regular model.

1976 PORSCHE 914 IN THE AUTOMOBILE ATLANTA SHOWROOM



Year	Model	Liters	Engine Code	Displacement CC	HP DIN @ RPM	Bore MM	Stroke MM	Comp. Ratio	Fuel System	Trans Type	Chassis Numbers
1970	914/4	1.7	W	1679	80/4900	90	66	8.2:1	MPC	914/11	470 29 00001-470 29 13312
1971	914/4	1.7	W	1679	80/4900	90	66	8.2:1	MPC	914/11	471 29 00001-471 29 16231
1972	914/4	1.7	EA	1679	80/4900	90	66	8.2:1	MPC	914/11	472 29 01400-472 29 21580
1973	914	1.7	EA	1679	80/4900	90	66	8.2:1	MPC	914/12	473 29 00001-473 29 27660
			EB	1679	80/4900	90	99	8.2:1	MPC	914/12	
			GA	1971	95/4900	94	71	7.3:1	MPC	914/12	
1974	914	1.8	EC	1795	79/4800	93	66	7.6:1	AFC	914/12	474 29 00001-474 29 21379
			GA	1971	95/4900	94	71	7.6:1	MPC	914/12	
1975	914	1.8	EC	1795	79/4800	93	66	7.3:1	AFC	914/12	475 29 00001-475 29 11369
			GC	1971	88/4900		71	7.6:1	MPC	914/12	
1976	914	2.0	GC	1971	88/4900	94	71	7.6:1	MPC	914/12	476 29 00001-476 29 04100

Year	Model	Liters	Engine Code	Displacement CC	HP DIN @ RPM	Bore MM	Stroke MM	Comp. Ratio	Fuel System	Trans Type	Chassis Numbers
1970	914/6	2.0	901/36	1991	110/5800	80	66	8.6:1	Weber	914/01	914 04 30011-914 04 32668
			901/37							914/05	
			901/38								
			901/39								
1971	914/6	2.0	901/36	1991	110/5800	80	66	8.6:1	Weber	914/01	914 14 30011-914 14 30443
			901/37							914/05	
			901/38								
			901/39								
1972	914/6	2.0	901/36	1991	110/5800	80	66	8.6:1	Weber	914/01	914 24 30011-914 24 30260
1972	916	2.4	901/38	2341	190/550	84	70	8.5:1	Weber	923/01	914 23 30011-914 23 30020
			911/86	2687	210/6300	90	70	8.5:1	Weber	923/01	(Prototype 914 14 30195)

Fuel System Types MPC = Manifold Pressure Controlled

AFC = Air Flow Controlled

Total Production Total 914/4 units produced, 1969-1976: 115,596

Total 914/6 units produced, 1969-1972: 3,360

FREE T-SHIRT!

Be the first on your block to wear one of these high quality tee-shirts with your favorite auto emblazoned on the front. These are available one to a customer for your first \$200.00 phone order. Tell us what size you want! Please, one to a customer.



ORDER INFORMATION

- We ship Federal Express Ground whenever possible. To insure prompt delivery, please provide your complete address. FE will not deliver to P.O. boxes.
- For other carriers, freight deliveries or international orders, please call for exact shipping and handling charges.
- All international orders will vary with destination and size of order.
- Shipments outside the USA may be subject to import charges. Such charges are the responsibility of the customer.
- Next day air delivery is avail through Federal Express or U.S. Mail. (Please call for exact prices)
- 2nd day air delivery is avail through Federal Express. Express charges apply.
- Saturday delivery is avail through Federal Express or U.S. Mail. An additional charge will apply.
- Hawaii, Alaska and Puerto Rico deliveries incur extra shipping charges.
- Oversized and freight items are individually quoted and the rates listed do not apply.
- All C.O.D. orders must have a credit card to back-up all shipping charges. A C.O.D. fee of \$8.00 will be charged.
- Refused C.O.D. orders will be charged for shipping, C.O.D. fee, as well as a 20% restocking fee on the parts unless canceled prior to 4 p.m. on the day of shipment.

Minimum Shipping and Handling charges via Federal Express:

Merchandise Subtotal

25.00 - 40.00	7.50
40.01 - 75.00	10.50
75.01 - 100.00	12.50
100.01 - 150.00	14.50
150.01 - 200.00	16.00
200.01 & UP	19.00

2nd Day Delivery Call*

Next Day Delivery Call*

Federal Express charges by dimensional weight on all shipments.

–SHIPPING HEAVY OR BULKY ITEMS–

Please call for charges. These items may require delivery by common carrier or be subject to oversize rates.

Scheduled Shipping Days for Federal Express from the Atlanta Metro Area



Returns & Exchanges:

Damaged Goods:

If there is any damage to any of the products in your order, please contact the delivering carrier at once. Keep the shipping carton and all packing material. Automobile Atlanta cannot initiate the claim with the carrier. The carrier will only deal with the recipient of the goods. Once you have a claim number, call us for a replacement part.

Should you find it necessary to return an item:

Please contact your personal salesman (listed on your invoice) for a return authorization number, at 770-427-2844. (Our shipping department will refuse any unauthorized return.) Please enclose a copy of your invoice, wrap the item securely and send your package back to us via insured and prepaid shipping. International customers are responsible for customs on returned items. **SHIPPING AND HANDLING FEES ARE NOT REFUNDABLE!**

Customer Service and Order Inquiries:

Write:

AUTOMOBILE ATLANTA/Customer Service
505 South Marietta Parkway • Marietta, Georgia 30060
Please include your phone number so that we may respond quickly.

Email Us:

You may email us at customerservice@autoatlanta.com

Phone Us:

You may call us at (770) 427-2844 ext.10; Fax us at (770) 424-6833. We will be happy to answer your questions Monday-Friday 10 A.M.-4 P.M. EST. (No collect calls) Have your invoice avail for faster service.

Core Returns:

Core invoices are shipped with a core tag provided. Please attach this to your core when returning the item. Cores being returned do not need a Return Authorization Number, but must have a copy of the invoice and the word CORE clearly visible on the outside of the box containing the core. Cores must be rebuildable and complete. Deductions will be made accordingly.

Return Policy:

1. No returns accepted after 30 days.
2. Returns are for exchange or merchandise credit, good for 2 years.
3. Refunds only after 30 days.
4. Parts must be in 100% resalable condition.
5. Customer will be responsible for shipping and handling round-trip of all orders placed and not canceled prior to 4 p.m. on the day of shipment.
6. Core credit given only on cores that are rebuildable.
7. All returns are subject to a 20% restocking fee.
8. No returns on special order parts, electrical items, books or manuals.
9. When referring to parts on our website or over the phone, please be aware that the letters G, R, U, B, stand for the following: G = Genuine • R = Aftermarket / Replacement • U = Used • B = Rebuilt or Reproduction

Please be aware that 90% of G parts are special order and are by nature non-returnable. If you have questions regarding this, please ask your sales person or feel free to email us. Thank you for your cooperation.

Index

A

Accelerator & Clutch Cable Set 76
Accelerator Cable And Heater Control Barrel
Nut 79
Adjustable Proportioning Valve 67
Air Cleaner Wing Nut, 1.7 29
Air Conditioning Kits 149
Air Conditioning Manual 163
Air Filters 27
Air Guide Plate 25
Align Bore Bearings 21
Alignment Shims & Bolts 58
Allen, 4mm 156
Alloy Center Cap 71
Alternator Belt Removal Tool, 914-6 158
Alternators, Rebuilt 128
Aluminum Gauge Plate 116
Appearance Group Console 103
Appearance Stripe Kits 119
ATE Brake Fluid 66

B

Baby Tornado Mirror 116
Back Pad Recovering Kit 113
Ball Joint Pin & Bolt 54
Basic Sweatshirt 237
Basic T-Shirt 236
Battery Charger & Maintainer 160
Battery Clamp and Bolt 136
Battery Covers 136
Battery Grounding Kit 136
Battery Quick Disconnect Switch 135
Battery Support Kit 88
Battery Tray Saver 135
Battery Tray Sealant 137
Beck 550 Spyder 111
Beefy Intermediate Plate 48
Big Master Cylinder 66
Bilstein Shocks 53
Bilstein Shocks, Front 53
Bilstein Shocks, Rear 60
Black Silicone For Tail Light Bodies 145
Blank Keys 3
Blaupunkt Audio 150
Blower & Heater Hoses, 914-6 17
Blower Box Hose and Seal 148
Blue Hose, Brake Reservoir 66
Body Kit, 9014 127
Boge Rear Shock Absorber, Rear 60
Boge Shock Absorbers, Front 53
Bosch Blue Ignition Coil 132
Bosch Racing Cutoff Switch 136
Boxed Swing Arm Set 58
Brake Bleeder/Vacuum Tester 67
Brake Caliper Paint 65
Brake Line Grommet 67
Brake Paste 64

Brakes Pads, Front, Carbon Kevlar 62
Branch Clamp Gasket 41
Branch Piece to Impellor Clamp 41
Brushable Seam Sealer 82
Bulb Kit 145
Bulbs, Blue Ion 143
Bulkhead Mount, 914-6 14
Bump Steer Kit 54
Bursch Muffler 35
Bursch Muffler, 914-6 15

C

Cable Attachments and Hardware Parts 76
Cad-Plated Strut Clamps 54
Calendar 238
Californian Mirrors 117
Camber Truss 61
Cam Oil Lines 14
Caps for Air Injection Tubes 33
Carburetor Rebuild Kits 27
Carburetor Set, 914-6 45
Carpet Kits, Custom 106
Carpet Strip Screws & Threshold Rivets
108
Cayenne Toy Trailer Set 238
CD Catalog 241
Center Cap, 914-6 69
Center Cap Remover 68
Center Cushion 105
Chalon Kit 127
Chassis Stiffening Kit 88
Chrome 914-6 Tailpipe 15
Chrome Driving Light Grilles 119
Chrome Trim Rings 70
Chrome Wheel 73
Cibie Lights 143
Classic Cap 237
Cleaned, Inspected, Aligned-Bored, Checked
Case 18
Clips For Emblems 118
Clutch/Flywheel Conversion Package, 914-6
17
Clutch Alignment Tool 155
Clutch Package, 914-6 16
Clutch Package Kit 34
Collapsible Oil Return Tube, 914-6 10
Color Wiring Diagrams 164
Combined Start & Ignition Switch, 914-6
138
Combined Starter Ignition Switch, 139
Compressor Tire Inflator 157
Console Wiring Harness and Schematic 137
Contact OL 129
Control Switch Slider 148
Control Unit Bracket, 914-6 129
Conversion Guide, 914-6 16
Cool Seat Savers 107
Corbeau Seat 104
Covers 124
Crane Electronic Ignition 131

Crest 3D Sticker 239
Crested Cuff Links 239
Crested Key Fob 239
Crested Sew-On Badge 239
Crest Mug 239
Crest Stickers 239
Cross Drilled Rotors, Front 62
Cross Member Repair 82
Crown Bushing 51
Cryogenic Frozen Rear Rotors 65
Cup Bushing 51
Custom Wire Sets 132
Custom Wire Sets, 914-6 131
CV Joint Grease 58
CV Joint Tool; All Models 155
CV Parts 59
Cylinder Heads 20

D

Dansk Muffler, 914-6 15
Dash Cover 114
Dash Face Material 117
Dash Kit 115
Dash Saver Mat, Carpet, Fabric 117
Dash To Windshield Bead 102
Dealership for Kids 238
Decal Set 57
Decel Valve 32
Deep Sump 23
Deerskin Driving Gloves 240
Deluxe Carb Linkage Kit 46
Deluxe Carburetor Linkage Kit 26
Diecast Model, 1:18 Scale 241
Digital Camber Gauge 157
Digital Pyrometer 160
DIN Radio Face Plate 116
Distler Porsche 356 238
Distributor, .009 132
Distributor Lube 134
Distributor Parts 134
Door & Ignition Keys 100
Door Catch Reinforcement 89
Door Jamb Repair Panel 90
Door Latch Parts 100
Door Panel Hardware Kit 114
Door Strap 100
Double GT Grille Lid 96
Driving Light Grille Screw & Clip Set 119
Driving Lights, 1973-76 141
Driving Lights, Reproduction 141
Dual Sending Unit 11

E

Early Intermediate Plate 48
Early to Late Shift Linkage Conversion Kit
78
Edging For Sheetmetal Front Engine Cover
96
Electric Antenna & Manual Mast 151
Electric Washer Kit 140

Electric Windshield Washer Pump 140
Emblems 118
Emergency Brake Boots 78
Emergency Brake Lever 79
Emergency Brake Pivot 85
Empi Mag Look-Alike Wheel 75
ENAMELED Car Badges 119
End Play Tool 155
Engine and VIN Stickers 161
Engine Bay Channel 85
Engine Controls, Rebuilt 29
Engine Gasket Kit 18
Engine Gasket Kit 914-6 17
Engine Grille Lettering 97
Engine Grille To Lid Welting 96
Engine Insulator Pad 120
Engine Insulator Pad Clip Set 121
Engine Lid Drip Pan 97
Engine Lid Drip Pan Hardware Kit 97
Engine Lid Hinge Bracket 97
Engine Mounting Hardware 19
Engine Mounts 18
Engine Oil Drain Valve 24
Engines, Rebuilt 18
Engine Shelf 85
Engine Shelf Plug 86
Engine Shelf Plug, 914-6 44
European License Plate Bracket 152
European Style Crest Plate 152
Euro Turn Signal Kit 144
Excellence Was Expected 2

F

Factory-Look Tool Kits 153
Factory Dash Bezels 137
Factory Driving Light Bulbs 143
Factory Look-Alike Driving Lights 141
Factory Mirror and Replacement Glass 115
Factory Repair Manual 162
Factory Repair Manual, CD 162
Factory Seat Loop 103
Factory Swaybar Bushings & Links 53
Factory Tail Pipes 36
Ferodo Front Brake Pad Set 62
Ferodo Rear Brake Pad Set 66
Fiberglass Bumper, GT 92
Fiberglass Bumper Replacements 92
Fiberglass Deposit Box 113
Fiberglass Hood, Reproduction 95
Fiberglass Hood Without Lights 96
Filler Neck To Expansion Tank Seal 42
Fire Extinguisher 158
First Gear Repair Set 49
Five-Lug Conversion Kit 75
Flexdam Front Spoiler 94
Floor Pan Hinge Reinforcement 84
Floor Pan Tar 82
Floor Pan Tar Premade Kit 83
Floor Pan Triangles 80
Flywheel, 914-6 11

Flywheel Lock 154
Foglight Lens and Gasket 142
Foot Step Profile Threshold Sill & Carpet Strips 108
Forever Black 93
Fresh Air Blower Motor 149
Fresh Air Grille Seal 148
Front/Rear Bumper, 916 92
Front and Rear Bumper Top Seal Kit 93
Front Brake Caliper Rebuild Kits 62
Front Caliper Rebuild Parts 63
Front Floorpan 80
Front Hood Seal 95
Front Spoiler Without Brake Ducts 94
Front Swaybar Mounting Plate 52
Front Tireboard 109
Front Trunk Carpet Kit 109
Front Turn Signal Lenses & Bucket 142
Front Valance Installation Kit 94
Front Windshield & Rear Window Kits 102
Frozen Rotors, Front 63
Fuchs Four-Lug Wheels 72
Fuchs Repro Wheel 69, 71
Fuel Filters 43
Fuel Injection Operation 33
Fuel Injection Pressure Sensor 130
Fuel Injection Pressure Tester 153, 155
Fuel Injector Cleaner 32
Fuel Injector Elbows 30
Fuel Line Grommets 44
Fuel Pump Boot 44
Fuel Pump For Carbs, Facet 43
Fuel Pump Mounts 44
Fuel Pump Relocation Kit 44
Fuel Rail Kit 30
Fuel Sender Gasket 42
Fuse Box Cover 136

G

Gas Caps 42
Gas Cap Seal 42
Gasket Block 31
Gas Tank Fuel Strainer Screen 53
Gauge Holder & Rings 116
Genuine Porsche Flashlight 138
Golf Balls 238
Grille Clips 97
Grommets and Boots 25
Ground Strap For Battery 135
GT-Type Rear Spoiler 98
GT Door Pull Straps 101
GT Flares 90
GT Front Oil Cooler 16
GT Front Valance 94
GT Oil Cooler Shroud 13
GT Rear Deck Lid 98
GT Rear Grille Material 96
GT Rear Quarter Panels 89
GT Seat, Repro Factory, 914-6 104

H

Halogen Bulbs 143
Hardtop Side Seal 121
Hardware Kit 154
Haynes Repair Manual 162
Headers 39
Headers, 914-6 14
Headlamp Conversion 141
Headliner 122
Head to Heat Exchanger Oversize Studs 20
Heater Blower Hoses 38
Heater Blower Update 39
Heater Control Valve 38
Heater Switches 79
Heat Exchanger/Muffler Hardware Kit 15
Heat Exchanger Kit 39
Heat Exchangers 37
Heat Exchangers, 914-6 15
Heavy Duty Oil Pump 23
Hella Horns 139
High Flow Cone Filter 28
High Performance Six Spring Disc 34
Hood Badges 3
Hood Pin Kit 95
Horn Button 57
Horn Repair Kit 57
Hoses, Aircraft Quality 38
Hot Fuel Injection Setup 30
Hot New Fuel Injection Kit 31
Hot Start Kit 128
Hub Cap, Plain For Steel Wheel 68
Hubcap and Badge, 914-6 70
Hubcap Badge 72

I

Ignition Coil, 914-6 131
IMSA Front Airdam/Bumper 92
Injector Boot and Injector Lead Repair Kits 32
Injector Pressure Sensor Boot Kit 32
Inner Firewall 82
Inner Rocker Panel 87
Inserts to Repair Shift Set Screw, Head Studs, Spark Plug Holes 20
Intake Boots 31
Intake manifold set 46
Intake Runner Boots 33
Interior Door Latch 100
Interior Light Bulb 144
Interior Plugs and Cup Washers 105
Intermediate Plate Bearings 49

J

Jacking Donut 84
Jacking Plate 157
Jack Post & Support 87
Jack Straps 153
James Dean Poster 240
Jump Start Pro 160

K

K&N Air Filter 28
 K&n Air Filter For High Performance 27
 K&N Air Filter Recharger Kit 28
 Key and Cylinder, Replacement 139
 Kinesis Wheel 68
 Koni Shocks 53
 Koni Shocks, Front 53
 Koni Shocks, Rear 60
 KYB Shocks, Front 53
 KYB Shocks, Rear 60

L

Laguna Jacket 237
 Laser Cut Aluminum Pedal Board 108
 Latch Cup, Door Vent and Drain Funnel 97
 Left and Right Floorpan 80
 License Plate, Euro 152
 License Plate Brackets 152
 License Plate Frames 152
 License Plate Light 144
 Loctite 11
 Logo Floor Mats 110
 Longitudinal Member Inner Right Frame Repair Kit, 2-piece 84
 Lower Fuel Tank Line Kit 43
 Lower Windshield Seal 124
 Lug Nuts, 914-6 69

M

Magnetic Spark Plug Socket 158
 Main Seals 19
 Maintenance Items Chart 133
 Major Service Kit 134
 Matched, Weighed And Rebrushed Rod Set 21
 Metal Fabricator's Handbook 91
 Millennium Wheel 73
 Mini-Air Compressor 74
 Mirrors, 911 117
 Moly Lube Oil 23
 Momo Steering Wheels 56
 Monza Style Manta Exhaust System 36
 Muffler, All 75 & 76 - Factory Look 37
 Muffler, Dansk, 2.0 37
 Muffler 1.7 and 1.8 37
 Muffler Bracket 34
 Muffler Bracket, 914-6 16
 Muffler Connector Pipe 34
 Muffler Nut and Bolt Kit, Muffler Gasket 37

N

Nipples, Nuts and Washers 42
 Nylon Trunk Lock Cam 98

O

Oil Baffle Plate Seal 19
 Oil Cap Seals, 1.8 24
 Oil Cooler Kit For Track Events 24
 Oil Cooler Seal Kit 24
 Oil Filter 23
 Oil Filter Removal Tool 154
 Oil Pressure Switch 11
 Oil Pressure Switch Boot, 914-6 11
 Oil Return Tube Seal O-Rings 10
 Oil Strainer Kit 22
 Oil Strainer Sump Plate Cover 10
 Oil Tank Kit, 914-6 14
 Oil Temperature Switch 11
 Oil Temp Sender 23
 Oil Temp Sending Unit 18
 Optima Battery 135
 Original Colors Chart 81
 Outer Firewall 86
 Outer Pulley Half 13
 Outer Rocker Panel 89
 Oval Grommet 44
 Owners Manuals 165

P

Pedal Board 108
 Pedal Cluster Rebuild Parts 77
 Pedal Pads 76
 Pedestal Spoiler 99
 Permatune Ignition Unit 130
 Pertronix Ignitor Electronic Ignition 131
 Piston & Cylinder Kit For 914-6 12
 Piston & Cylinder Kit For 914-6, Big Bore 12
 Piston & Cylinder Kits 21
 Piston Ring Compressor 154
 Pivot Pin, 3-Hole 143
 Polished Center Cap 70
 Por 15 Marine Clean 42
 Porsche Crest Cap 237
 Porsche Crest Polo Shirt 236
 Porsche Polo Shirt 237
 Porsche Tee Shirt 237
 Poster, 24 Hour Lemans 1970 165
 Poster, Auto Atlanta 240
 Poster, Marathon de la Route 165
 Power Bleeder 67
 Press Sign for Late Seatbelts 125
 Pushrod Tubes 23

Q

Quaife Locking Differential 50
 Quarter Panel Sail Replacement 89

R

Rack and Pinion Cover Seal 52
 Radar and Laser Detector/Scrambler 3
 Radar and Laser Detector/Scrambler

3

Rainshield Air Cleaner 45
 Rear Brake Caliper Rebuild Instructions 65
 Rear Branch Piece Clamp 41
 Rear Bushings 60
 Rear Caliper Adjustment Tool 65
 Rear Caliper Rebuild Kit 65
 Rear Caliper Rebuild Parts 64
 Rear Carbon Kevlar Brake Pad Set 66
 Rear Deck Hinge Pivot 87
 Rear Deck Lid Stripe 119
 Rear Floorpan 80
 Rear GT Valance 95
 Rear License Plate Lights 144
 Rear Rotor Screws 65
 Rear Shift Kit, 916 49
 Rear Slotted Rotors 64
 Rear Springs 61
 Rear Sway Bar Kit 59
 Rear Targa Top Seal 125
 Rear Trunk Carpet 113
 Rear Trunk Floor 85
 Rear Trunk Insulator Pad 121
 Rear Trunk Lid Latch 98
 Rear Trunk Lock Seal 99
 Rear Update Kit 145
 Rear Valance 95
 Rear Valance Installation Kit 95
 Rear Valance With No Notch 94
 Rear View Mirror Interior 118
 Rear Wheel Bearing 59
 Rebuilt 914-6 Alternator 13
 Rebuilt and Balanced 914 Crank 21
 Rebuilt CV Axle 58
 Rebuilt Front Calipers 63
 Rebuilt Fuel Pump 43
 Rebuilt Instruments and Gauges 146
 Rebuilt Pedal Cluster 76
 Rebuilt Rear Calipers 64
 Rebuilt Starter 128
 Rebuilt Transmission 48
 Reconditioned Fuel Tank 42
 Recovered Dash Pad 114
 Recovered Door Panel 113
 Recovered Steering Wheel 57
 Recovered Visors 117
 Recovering Kit For Deposit Box Top 105
 Refinished Targa Top Roof 122
 Relay Board, Rebuilt 128
 Relay Board Cover 128
 Relays 129
 Remachined and Balanced Flywheel 22
 Repair Handbook 162
 Replacement Bulbs 145
 Replacement Catalytic Converter 35
 Replacement Fan, 914-6 13
 Replacement Rubber Pieces 123
 Reproduction 5-Speed Shift Knob 77

Repro Seat Loop 103
Repro Visor Clip 117
Restoration Guide To Authenticity 164
Reupholstered Seats 103
Right Inner Wheel House 88
Right Rear Suspension Console 86
Riviera Mag 71
Rocker Clamshell 85
Rollbar 99
Rotisserie 90
Rotisserie Plans 90
Rubber Kit 122

S

Scatcam For Carbs 22
Scat Lifter Set For Carbs 22
Screws 112
Seat Belt Hardware 126
Seat Belt Set 124
Seat Hinge Bracket 84
Seat Upholstery Kits 105
Semi-Solid Transmission Mount 49
Sheepskins 107
Sheet Metal Handbook 91
Sheet Metal Kit, 914-6 13
Sheet Metal Screw Kit 24
Shift Boot, Leather 78
Shift Bushings 78
Shift Coupler/ Threaded Insert Shift Set
Screw 79
Shifter Rebuild Kit 78
Shift Kit, 916 79
Short Shift Kit 77
Shorty Floorpan 83
Sidermarker Lenses 143
Side Vinyl Kit 118
Sill Threshold Plates 87
Silver Plated Keychain Fob 240
Snowplow Front Spoiler 93
Soft Socket 157
Sparco 4-Point Belt 126
Spark Plug Towers & Wire Clips 135
Speaker Grille Set 108
Speaker Kit 151
Special Edition Spoiler 93
Spoiler, Front with Brake Ducts 93
Sport Seat 104
Squeeges, End Caps, Outer Fuzzy Strips,
and Squeeze Gutters 101
Stacked, Branch, Standard, Vacuum
Elbows 29
Stainless Steel Brake Lines 67
Stainless Steel Fuel Line Kit 47
Steel Wheel Center Caps and Lug Nut
Covers 72
Steering Column Covering 116
Steering Column Wheel/Ball Bearing
139
Steering Wheel Recovering Kit 57

Stock Piston & Cylinder Kits 21
Stone Guard 83
Street Aluminum Pedals 76
Stub Axles, 914-6 58
Supertrap Muffler 39
Suspension Kits 55
Swaybar Adapter Kit 52
Swaybar Bushings & Mounting Plates
59
Swaybar Drop Link Bushing 52
Swivel Foot For Rocker Arms 22
Synchrometer 47
Synchros, Sliders and Dogteeth 51

T

T-Shirt Offer 231
Tail Light Lenses 142
Taillight Lens Seal 144
Tech Series by Dr. 914 164
Tech Specs Reprint 162
Tech Tips 700 163
Tensioner Update Kit, 914-6 12
Test Light, 12-Volt 158
Thermostat Bellows & Parts 25
Throttle Return Spring/Barrel Nut Bolt
30
Timing Decals, 914-6 160
Timing Hole Plug 24
Tinted Windshield 102
Tire Gauges 156
Top Bolster Plugs 122
Top Holders 98
Torque Specs 125
Torsion Bar Grease Seals 52
Torsion Bars 52
Transmission Filler Tool 155
Transmission Gasket Kit 48
Transmission Ground Strap 50
Transmission Mount 49
Transmission Roll Pin and Plastic Spacer
50
Trigger Points 132
Trim Paint Satin Black 89
Tune-up/Service Kit, Bosch Distributors,
914-6 131
Turbo Tail Spoiler 99
Turbo Tie-Rod Kit 54
Turn Signal Lenses, Amber/White 144
Turn Signal Switch 70-71 139
Two Syllable Tee Shirt and Sweatshirt 2

U

U-Joint Coupling Bushings 79
Ultimate Air Dam 93
Ultimate Braking Kit 62
Upper Dash Kit 115
Upper Fuel Line Kit 31
Upper Roll Bar Pad 114
Upper Strut Bushings 54

V

Vacuum Line Kit 29
Valve Adjustment Tool 154
Valve Adjust Tool, 914-6 154
Valve Cover Gasket Set For 914-6 12
Valve Covers, 930, For 914-6 12
Valve Stem Cover Set 74
VDO Gauge Spacer Ring 147
VDO Oil Pressure Hose Kit 23
VDO Speedo Angle Drive 50
Vent Window Seals 102
Vinyl Cleaner 105
Viton Push Rod Tube Seal Kit 22
Voltage Regulator - Screened 128
Volt Tach Dwell Meter 158

W

Wall Protector and Parking Mat 241
Warm Air Elbows 38
Washer Hose 140
Weatherstrip Adhesive 101
Weber Carb Book 27
Weber Carburetor Float Level 46
Weber Carburetor Kits 26
Weber Carburetor Rebuild Repair Kit,
914-6 46
Welder's Handbook 91
Weltmeister Camberplate Kit 54
Weltmeister Front Swaybars 52
Weltmeister Short Shift Kit 77
Wheel Adapters 73
Wheel Bearings 53
Wheel Center Cap Decals 72
Wheel Center Caps 72
Wheel Cleaner 69
Wheel Locks 71
Wheel Nuts and Bolts 70
Wheel Studs, Screw-In 71
Window Cranks 101
Window Regulator Button 100
Window Tint 119
Windshield Bolster Gauge Holder 148
Windshield Chrome Pieces 103
Windshield Top Seal, Topside Seal and
Vertical Rollbar Seal Kit 101,
121
Windshield Washer Nozzles 140
Windshield Washer Wiper Switch 140
Wiper Washer Switch and Parts, 1970-
71 138

Z

Z-Beam Headlights 141
Zimmerman Cross Drilled Rear Rotor
65
Zinc Spray Paint 25

GENUINE PORSCHE



MEN'S BASIC T-SHIRT

High-quality T-Shirt from the Basic collection. Double seams on front and shoulders. Discreet Porsche Logo in dark gray on the front left. Available in white, yellow, red and black. 100% cotton. Sizes: S, M, L, XL, XXL. State color and size when ordering.

Men's Basic T-Shirt ... [GWAP 619 00 \\$35.00](#)



Women's Basic T-Shirt

Stylish fitted, feminine T-Shirt from the Basic collection. Double seams on front and shoulders. Discreet Porsche Logo in dark gray on the front. Available in light blue, white, pale pink and black. 100% cotton. Sizes: S, M, L, XL. State color and size when ordering.

Women's Basic T-Shirt ... [GWAP 628 00 \\$35.00](#)



Porsche Crest Polo Shirt

Meticulously finished polo shirt with Porsche Crest on the front left. Back slightly longer than front. Side slits. Buttons with Porsche logo. 100% cotton. Sizes: S, M, L, XL, XXL.

Porsche Crest Polo Shirt ... [GWAP 591 00 17 \\$60.00](#)

APPAREL



Porsche Crest Cap

Baseball cap with Porsche Crest. Contrasting piping and small Porsche logo on peak. 100% cotton. One size fits all.

Porsche Crest Cap ... [GWAP 080 000 17 \\$20.00](#)



Classic Cap

Baseball cap with Porsche logo. Contrasting logo piping on peak. Metal buckle with embossed Porsche logo. Available in blue and beige. 100% cotton. One size fits all.

Classic Cap ... [GWAP 080 002 15 \(blue\) \\$20.00](#)

Classic Cap ... [GWAP 080 003 15 \(beige\) \\$20.00](#)



Porsche Tee Shirt

In White, Yellow, and Black. Sizes S, M, L, XL. Teeing off, sailing or just kicking back, this is the foundation of your casual weekend wardrobe. Tee has separate ribbed collar. Banded sleeves. Tees are made of heavyweight 100 percent cotton pique knit.

Porsche Tee Shirt ... [GWAP9160010 \\$35.00](#)



Porsche Polo Shirt

In Light Blue, Red, White, and Black. Sizes S, M, L, XL.

Porsche Polo Shirt ... [GWAP52200L14 \\$54.13](#)

Porsche® Laguna Jacket

There is no denying the timeless classic of the varsity jacket: the trim waist and broad-shouldered cut define a uniquely athletic look. Porsche's version starts with a heavyweight melton wool body, quilted lining, and snap front, adds calf leather sleeves with ribbed trim, and then finishes with detailed multicolor embroidery of the Porsche® crest and script. Sizes Small to XXL.

Laguna Porsche® Jacket ... [GCOL 946 00 \\$270.00](#)

Basic Sweatshirt

High-quality sweatshirt from the Basic collection. Comfortable fit. Large, red Porsche logo on the front. Dark blue. 100% cotton. Sizes: S, M, L, XL, XXL.

Basic Sweatshirt
... [GWAP 660 00 \\$65.00](#)



GENUINE PORSCHE

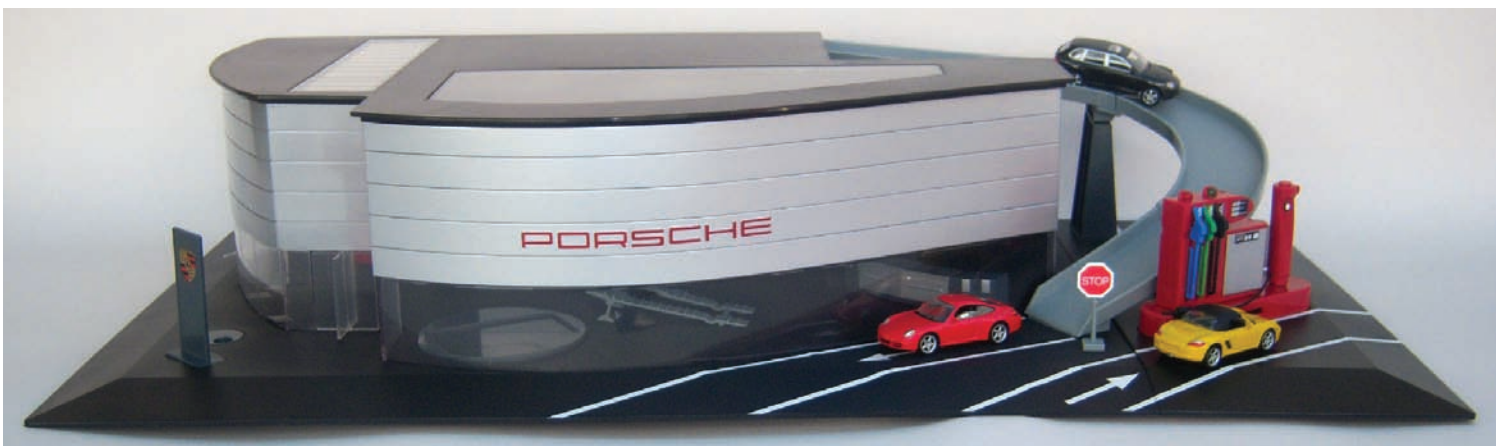

Porsche Dealership for Kids

Sturdy reproduction of a Porsche Dealership. Various functions: lifting platform, lift, filling station, car wash, descent ramp. Includes three model cars, road signs and salesroom fittings. Detachable roof. Suitable for ages 4 and up.

Porsche Dealership for Kids ... [GWAP 040 003 15 \\$114.00](#)

Porsche Golf Balls

Set of three high-tech golf balls (Titleist NXT) with Porsche logo. High-speed core and extremely durable surface for optimum distance and soft drive.

Porsche Golf Balls ... [GWAP 060 040 16 \\$21.60](#)



Distler Porsche 356

Historic Distler Porsche Electromatic 7500 with genuine ignition key for starting the motor. Synchronized pinion gear with reverse, neutral and two forward gears. Uses two-piece steering shaft for steering and gear changes.

Distler Porsche 356
... [GWAP 024 000 17 \\$295.00](#)

Cayenne Trailer Set With 356

Trailer set with Cayenne S, double-axle trailer and 356 B Coupé [1960]. Limited edition of 1,500 sets. Cayenne S: Lapis Blue Metallic; black interior. 356 B Coupé: Ivory White. Made of metal and plastic. 1:43 scale.

Cayenne Trailer set with 356 ... [GWAP 020 SET 12 \\$98.00](#)



Porsche Calendar

Official Porsche Calendar for 2008 featuring snapshots that reflect the unique and fascinating appeal of Porsche. Each month has a picture of a car in the new Porsche colors taken against a backdrop of dramatic natural scenery. Some of the cars blend in with the world around them, while others form a striking contrast to some of the most breathtaking landscapes on earth. Supplied with an attractive collector's coin. Size 23.25" by 22".

Porsche Calendar ... [GWAP 092 001 17 \\$50.00](#)

COLLECTIBLES



Porsche Crest Mug

China mug with coloured Porsche Crest and gold rim. Not dishwasher safe.

Porsche Crest Mug ... [GWAP 107 064 12 \\$12.00](#)



Crested Key Fob

In red, yellow, green, black, brown - specify color.

Crested Key Fob

... [GWAP05009216 \\$21.60](#)



Porsche Crest 3D Sticker

Porsche Crest as sticker. Synthetic resin. Available in two sizes.

Porsche Crest 3D Sticker

... [GWAP 107 065 14](#) [dimensions: 15 x 19 mm] \$6.00

Porsche Crest 3D Sticker

... [GWAP 107 066 14](#) [dimensions: 25 x 33 mm] \$8.40



Porsche Crest Cuff Links

Elegant cuff links in the shape of the Porsche Crest. With bar. Enamel on 925 sterling silver, partially gold-plated. Dimensions: approx. 13 x 18 mm

Porsche Crest Cuff Links ... [GWAP 050 140 15 \\$81.60](#)



Porsche Crest Sew-On Badge

Porsche Crest as sew-on badge. Polyester. 2 x 2.5 inches.

Porsche Crest Sew-On Badge

... [GWAP 101 067 14 \\$9.00](#)

Porsche Crest Stickers

Beautiful factory identity decal direct from the Porsche factory. Show your Porsche enthusiasm with this weatherproof highly colorful self adhesive decal.

Large Porsche Crest Sticker, 15" by 12" ... [GWAP 013 003 \\$11.00](#)

Medium Porsche Crest Sticker, 2.5" by 2" ... [GWAP 013 002 \\$3.30](#)

Small Porsche Crest Sticker, 1.5" by 1.25" ... [GWAP 013 001 \\$2.20](#)



EXCELLENCE IN

Auto Atlanta Poster

24" x 36" ... [RPS1027 \\$14.00](#)

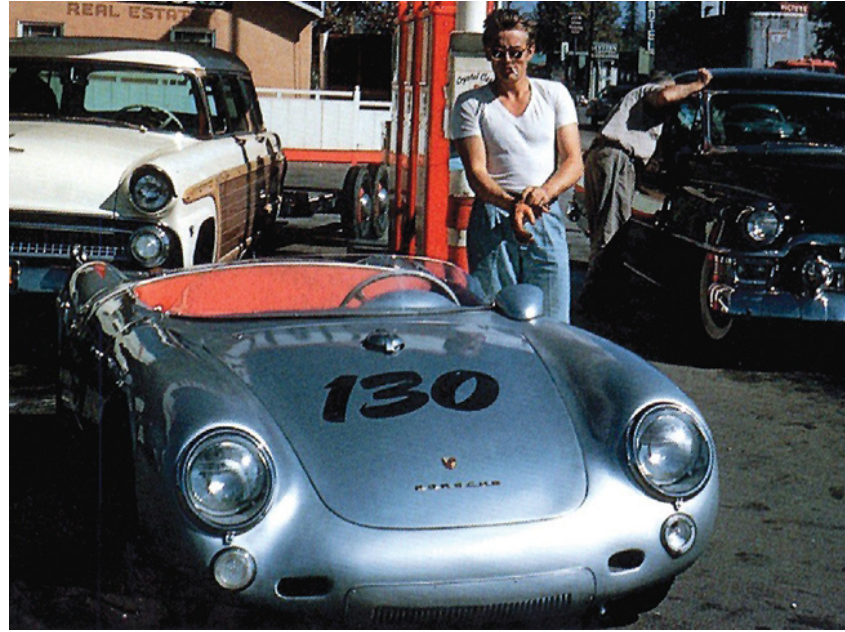
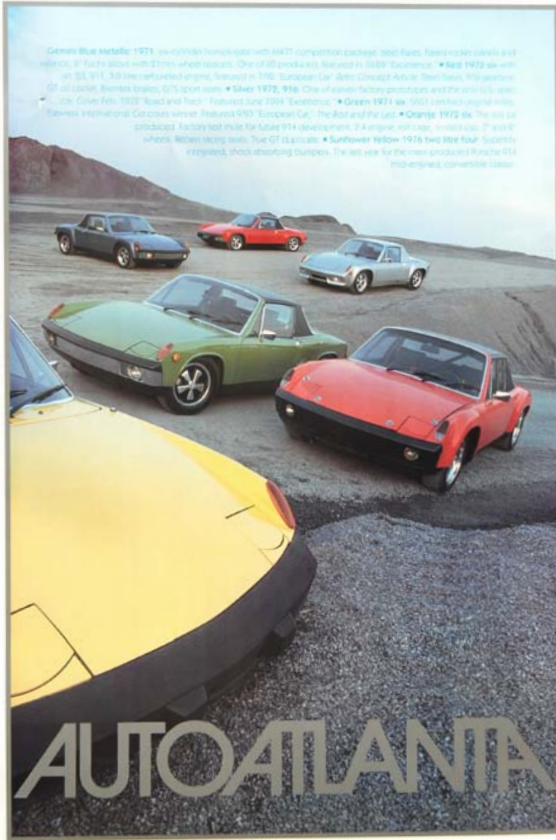

James Dean Gas Pump Poster

James Dean Poster, 55"x24" ... [RPS1054 \\$19.50](#)



Deerskin Driving Gloves

Supple and comfortable, these classic full fingered driving gloves are the finest quality on the market today. Hand-crafted of buttery-soft genuine deerskin, they feature vent holes, piping, outside stitching for comfort, and a Velcro wrist closure. Available in Black, Chocolate Brown and Tan, in sizes Small, Medium, Large and Extra Large. Specify size when ordering. Measure your hand around the palm. Up to 8 inches=SM. 8-8.5 inches=MED. 8.5-9 inches=LG. OVER 9.5 inches= XL

Deerskin Driving Gloves ... [RDG004 \\$60.44](#)

Silver Plated Keychain Fob

All metal key chain with a very detailed 2 inch model of the Porsche 914. These keychains are cast, silver plated and hand polished in Germany. They come in a nice black gift box - an ideal treat for the 914 owner and enthusiast!

Silver Plated Key Chain Fob ... [RHC31471 \\$26.95](#)



ACCESSORIES

Wall Protector and Parking Mat

Protect your door as well as your garage wall while getting in and out of your vehicle. Wide, padded vinyl strips keep those door edges perfect. Mounts on the wall to provide all around protection.

Parking Mat ... [RPM1001 \\$21.45](#)

Wall Protector ... [RWP1004 \\$15.35](#)



CD Catalog

CD of all of our print catalogs: 356, 911, 912, 914, 924, 944, 928, 968, and Boxster. The technical side of the CD contains many technical articles and pamphlets written by Dr. 914. Prices may not be accurate on some of the older catalogs; call, email, or check online for current price. 30-minute Porsche related video and tour of 914 World Headquarters, Automobile Atlanta.



CD Catalog ... [CDCAT1 \\$1.00](#)



Diecast Model, 1:18 Scale

Beautifully crafted Porsche 914 diecast model. Highly detailed and realistic. By Revell. Available in blue or yellow.

Porsche 914, 1:18 Scale Model, Yellow ... [RDCR 08975 \\$49.45](#)

Porsche 914, 1:18 Scale Model, Blue ... [RDCR 08976 \\$49.45](#)



Enameled Car Badges

Add international glamour to your automobile. These high quality, enameled badges have bright colorful images on a shiny chrome background. Each, \$20.90

German Flag ... [RAC 2071 \\$20.90](#)

USA Flag ... [RAC 2010 \\$20.90](#)

Deutschland Eagle ... [RAC 2009 \\$20.90](#)

Stuttgart Horse ... [RAC 2024 \\$20.90](#)

AUTO ATLANTA

505 South Marietta Pkwy.
Marietta, Georgia 30060

On the Web at www.AutoAtlanta.com

NEWS FLASH!

Free shipping on orders over \$75.00!
Hurry, offer ends Dec. 3, 2007

TECH TIPS 700

A COMPLETE TECHNICAL GUIDE
TO THE VW-PORSCHE 914



BY
GEORGE A. HUSSEY, IV

Tech Tips 700

By George Hussey. Newly printed third edition, Tech Tips 700 is the bible when it comes to guides or manuals to operate and maintain your Porsche 914. This little red book has been hailed by 914 owners as a must have companion to their beloved cars. Road & Track magazine says that no 914 owner should be without it.

Tech Tips 700 ... RBK 7074 \$19.95

PORSCHE ENTHUSIAST
123 ELM STREET
ANYTOWN, USA 12345

BULK RATE